

WAVE PROPAGATION &  
BROADBAND  
COMMUNICATION  
ENGINEERING

**5TH SEM**

**PRABHAKAR RATH**

# Ch – 1 Electromagnetic waves

## 1.1 : Introduction to Electro Magnetic Waves

When the power is radiated into the free space is governed by the characteristics of free space. If such power escapes on purpose it is said to have been radiated, then it propagates in space in the particular shape is known as Electromagnetic wave. Free space is the space that does not interfere with the normal radiation and propagation of radio waves.

- EM waves are energy travel through free medium at the velocity of light, which is approximately  $3 \times 10^8$  kilometer/second.
- Electromagnetic waves are similar to propagation of out ward travel of water wave on a river after a stone has been thrown into it with the only difference is that water waves are longitudinal & EM waves are transverse.
- The velocity of EM wave decreases when it travels into a medium.
- Electromagnetic waves can be related to the term „power density“ and the direction of electric field.
- The magnetic field and Electric field propagation are mutually perpendicular in electromagnetic waves.
- In case of free space electromagnetic waves is spread uniformly in all direction form a point source. So the wave front is just like spherical.
- The wave length ( $\lambda$ ) of an electromagnetic wave is the physical distance the wave travel in one cycle i.e.  $\lambda = vt$   
 $v =$ Velocity of light.  
 $t =$ Time taken by the wave to travel through on cycle.  
 $\lambda =$ Wave length.

## 1.2 Effects of environment

When propagation near the earth is occurs the factors which are not available in free space must be considered. These propagated waves will be reflected by the ground, mountains and buildings. They will be refracted as they pass through layers of the atmosphere which have different degree of attenuation. The EM wave may diffracted around tall, massive objects. They also interface with each other, when two waves from same source meet after having travelled by different paths.

### 1.2.1 Reflection of waves

- Reflection will occur due to presence of building mountains, ground when the EM wave is travelling in free space.
- In case of reflection the brightness of EM wave is progressively reduced due to reflection the EM wave loses some energy on reflected surface.
- In case of reflection the EM wave vector is perpendicular to conducting surface.
- If the reflecting surface is rough reflection will be much same as smooth surface.

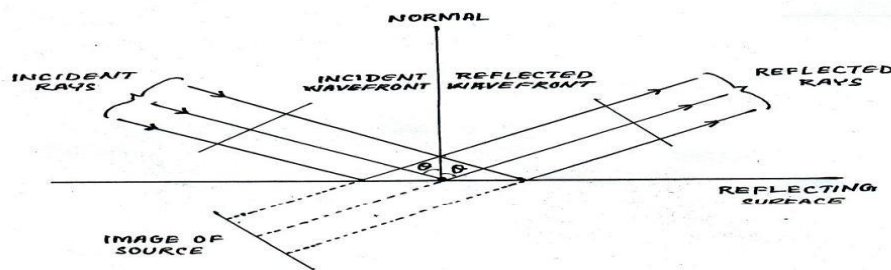

**Fig 1.1** Reflection of electromagnetic waves

- If the angle of incidence rises then it is called Rayleigh criterion.
- It is unity for perfect conductor or reflecting surface and less than that for practical conducting surface.
- The reflection coefficient  $\rho$  is defined as the ratio of the electric intensity of the reflected wave to that of incident wave.
- The most important condition which causes reflection is the electric vector must be perpendicular to the conducting surface results generation of surface current.

### 1.2.2 Refraction of waves

- Refraction takes place when electromagnetic waves pass from one propagating medium to a medium having a different density.
- This situation causes the wave front to acquire new direction in second medium and is brought about by a change in wave velocity.
- In case of Refraction the first signal is being propagated in the free space in case of high wall medium.

- When the bandwidth of light is increases the visual of particle is slightly reduced.
- Here in the below figure the incident ray travel from rarer to denser medium by the effect of refraction.

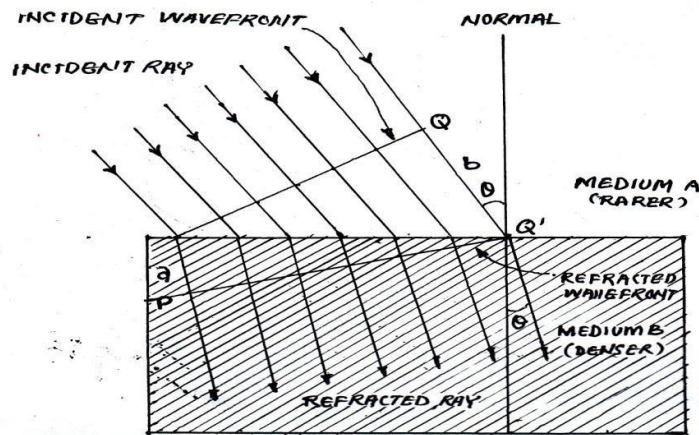

**Fig 1.2** Refraction of electromagnetic waves

### 1.2.3 Interference of waves

- When two waves traveled and left from one source but when they met each other Interference occurs.
- This happens very often in high frequency sky wave propagation and in Microwave space-wave propagation.
- It also occurs when a microwave antenna is located near the ground, and wave Reach the receiving point not only directly but also after being reflected from the ground.
- At frequencies up to the very high frequency interference will not be significant because of the large wave lengths of such signals.
- The below figure occurs when a microwave antenna is located near the ground, and the waves reach the receiving point only directly after being reflected from the ground.

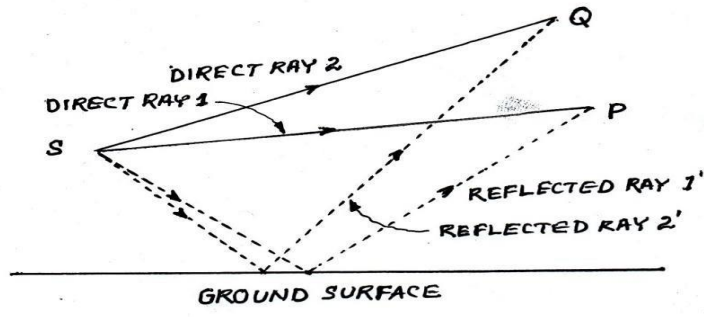

**Fig.1.3** Interference of electromagnetic waves

**1.2.4 Diffraction of waves**

- It is caused in electromagnetic wave when it is affected by the presence of small Slits in a conducting plane or sharp edges of obstacle.
- It involves change of direction of waves which are travel through a medium.
- Diffraction is depends on the wavelength of signal wave i.e. it increase with increase in wave length and decrease with decrease in wave length.
- Diffraction plays an important role in preventing the narrow pencil of radiation which is often desired, by generating unwanted side lobes.

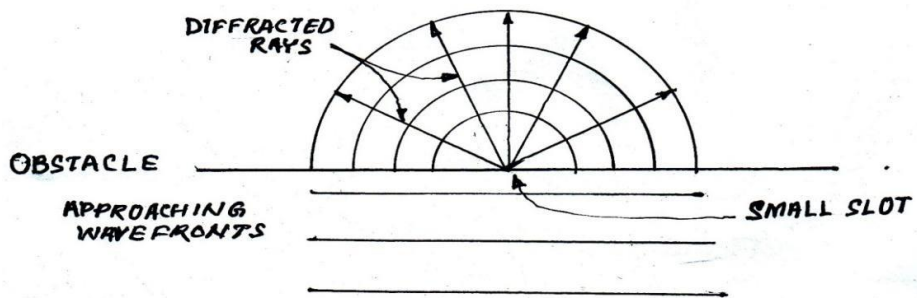

**Fig.1.4** Diffraction of electromagnetic waves

## Ch-2. Wave Propagation & Antenna.

### 2.1 Wave radiation in space

- The space means the free space where there is no interference with the normal radiation & propagation of radio waves. Thus it has no magnetic or gravitation fields, no solid bodies and no ionized particles.
- However, the concept of free space is used because it simplifies the approach to wave propagation, since it is possible to calculate the conditions if the space were free and then to predict the effect of its actual properties.
- Also propagating conditions sometimes do approximately those of free space, particularly at frequencies in the upper UHF region.
- Since radiation & propagation of radio waves cannot be seen, all our description must be based on theory which is acceptable only to the extent that it has measurable and predictive value.

### 2.2. Propagation of Waves

In earth environment, electromagnetic waves propagate in ways that depend not only on their own properties but also on those of the environment itself. Waves travel in straight line, except where the earth and its atmosphere alter their path. Frequencies above the HF generally travel in straight line. They can propagate in following ways such as:

#### 2.2.1 Ground wave propagation

- Ground waves propagate along the surface of the earth.
- The propagation takes place in medium frequency range i.e. (0.3 -3MHz).
- This is the frequency range where AM broadcast occurs.
- The ground wave propagation is limited to 100 miles.
- Here atmospheric noise, Man-made noise, thermal noise from electric field create disturbance in ground wave propagation.
- The ground wave may be attenuated due to diffraction near the earth.
- In ground wave propagation there is communication that happens between two stations as shown in below figure.

- If the distance between the two antennas is kept long then there is a reduction of field strength due to ground and atmosphere absorption which reduces the amplitude of signal received.

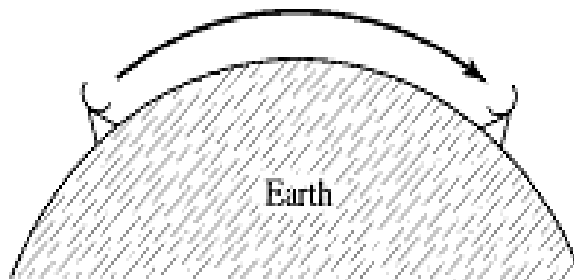

**Fig.2.1** Ground wave propagation of electromagnetic waves

### 2.2.2 Sky Wave Propagation

- The range above the surface of earth about 30-250 miles are called ionosphere where sky wave propagation happens.
- The signals being reflected from the ionosphere which contains several layers of charged particles.
- The range of frequency for sky wave propagation is above 300 MHz.
- Here in sky wave propagation long distance HF communication are permitting over the horizon VHF communications.
- In sky wave the HF range of frequency can transmit.
- There is a term called „SKIP DISTANCE“ which is the shortest distance from a transmitter, measured along the surface of the earth at which a sky wave of fixed frequency will return to earth.

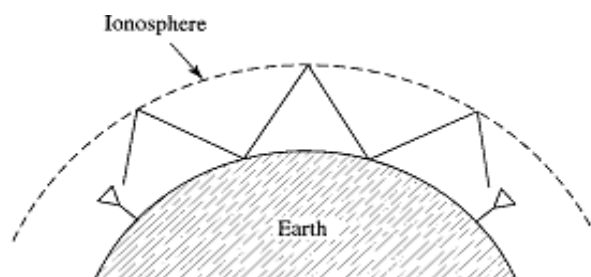

**Fig.2.2** Sky wave propagation of electromagnetic waves

### 2.2.3 Space Wave propagation

- Space wave propagation is limited to curvature of earth.
- They can propagate very much like electromagnetic wave in free space.
- The radio waves having high frequency are basically called as space wave.
- These waves have the ability to propagate from transmitter to receiver antenna.

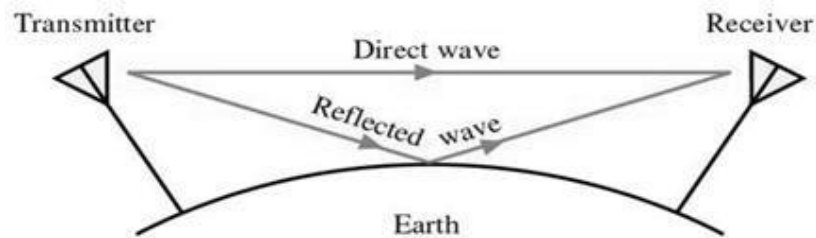

**Fig.2.3** Space wave propagation of electromagnetic waves

- The limitation of space wave propagation are:
- These waves are limited to the curvature of the earth.
- Due to line of sight propagation occur in space wave propagation, the antenna of both transmitter side & receiver side must be increased.

- **Radio horizon:**

The radio horizon for space waves is about four thirds as far as the optical horizon. This effect is caused by the varying density of the atmosphere, and because of diffraction around the curvature of earth. The radio horizon can be calculated by using the formula:

$$D_t = 4\sqrt{h_t}$$

Where  $D_t$  = distance from transmitting antenna

$h_t$  = height of transmitting antenna above the ground

The above formula naturally applies to the receiving antenna. Then the total distance can be given by the formula:

$$D = D_t + D_r = 4\sqrt{h_t} + 4\sqrt{h_r}$$

$D_t$  = Total distance between transmitting antenna to receiving antenna



## 2.2.4 Tropospheric scatter propagation

- In this method of propagation uses the tropospheric scatter phenomenon, where radio waves at particular frequencies are randomly scattered as they pass through upper layers of the troposphere.
- A beam of radio signals are aimed at the tropopause are transmitted in half way between the sender and receiver sides, as they travel through the same medium some of the energy reflected back to the earth.
- It is used as a reliable form of radio communication link that can be used regardless of the prevailing tropospheric conditions.
- It is also used for remote telemetry or other links where low to medium rate data needs to be carried.
- Tropospheric scatter propagation having two forms of fading, they are
- In the first is fast occurring several times per minute at its worst, with maximum signal strength variations in excess of 20 dB, also called Rayleigh fading and is caused by multipath propagation.
- In the second kind of fading is very much slower and is caused by variation in atmosphere conditions along the path.

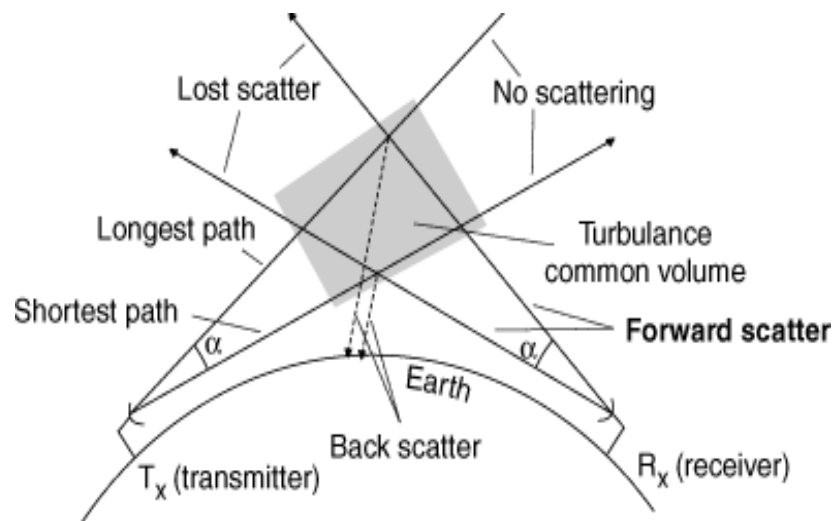

**Fig.2.4** Tropospheric scatter wave propagation of electromagnetic waves

- Here in the above figure shows two directional antennas are pointed so that their beams intersect midway between them above the horizon.

- If one of these is a UHF transmitting antenna and the other is a UHF receiving antenna, the sufficient radio energy will be directed toward the receiving antenna to make this a useful communication system.

## 2.3 Radiation Mechanism of an Antenna

- An antenna is a structure capable of radiating or receiving electromagnetic waves.
- Their function is to couple the transmitter and receiver to space.
- In case of microwaves the transmitting and receiving antennas should be highly directive.
- An antenna is very much similar to a resonant circuit which has ability to transfer energy from electrostatic to electromagnetic.
- If the impedance match is correct the energy being transferred will radiate energy into atmosphere in the same way a transformer transforms energy from primary to secondary.
- An antenna is a structure that is generally a metallic object, often a wire or group of wires used to convert high frequency current into electromagnetic waves & vice versa.
- The spacing, length & shape of the device are related to the wavelength  $\lambda$  of the desired transmitter frequency i.e. mechanical length is inversely proportional to the value of frequency  $f$ .

$$T=1/f$$

$$T=\text{time period}$$

$$f=\text{Frequency}$$

For an antenna operating at 50MHz time period  $T= 0.02 \mu\text{s}$ .

### 2.3.1 Electromagnetic Radiation

- When RF energy is fed to a mismatched transmission line standing waves occur.
- This process is considered unwanted in the transfer of energy to the radiation device.
- By the ends of the transmission line, that more surface area of the wire is exposed to the atmosphere and enhances the radiation process.
- when two wires are bent at 90 degree to each other radiation efficiency is improved
- The electric and magnetic fields are now fully coupled to surrounding space instead of being confined between two wires, maximum radiation results.

## 2.4 The Terms Related To Antenna

### 2.4.1 The Antenna Gain

In electromagnetic an Antenna gain is simply a key performance figure which combines Antenna's directivity and electrical efficiency.

It is expressed in terms of decibel (dB). It also relates the intensity of an antenna in a given direction to the intensity that would be produced by a hypothetical ideal antenna that radiates equally in all directions.

### 2.4.2 Directivity

It is defined as the figure of merit of the antenna. It measures the power density of the antenna by an ideas isotropic radiator which radiates in the direction of its strongest emission to the power density radiated. It is an important measure because most emissions are intended to go in a particular direction or at least in a particular plane. It is the maximum value of directive gain is represented as  $D(\theta, \phi)$ , compares the radiations  $U(\theta, \phi)$  that an antenna creates in a particular direction against the average value over all direction

$$D(\theta, \phi) = \frac{U(\theta, \phi)}{P_{\text{total}} / 4\pi}$$

### 2.4.3 Directive gain

Directive gain is defined as the ratio of the power density in a particular direction of one antenna to the power density that would be radiated by an unidirectional antenna. Here two important points to be remember. The larger the antenna, the higher the directive gain. Non resonant antennas have higher directive gain than resonant antenna.

### 2.4.4 Radiation Resistance

The comparison between power Radiated by an antenna to the of the current at the feed point referred as Radiation resistance.

### 2.4.5 Bandwidth

The term band width refers to the safe range of frequencies the antenna will radiate effectively the antenna will shows best performance throughout this range of frequencies.

### 2.4.6 Beam width

The beam width of an antenna is described as the angle created by comparing ½ power points (3dB) on the main radiation lobe to its maximum power point.

### 2.4.7 Efficiency

It is a measure of the efficiency with which a radio antenna converts the radio frequency power accepted at its terminals into radiated power. It is defined as the ratio of the total power radiated by an antenna to the net power accepted by the antenna from the connected transmitter. It is expressed in terms of percentage & is frequency dependent. It can also be described in decibels. For wire antennas which have a defined radiation ratio of the radiation resistance to the total resistance of the antenna including ground loss conductor resistance.

$$P_{in} = P_d + P_{rad} \dots\dots\dots (i)$$

$P_{in}$  = Power delivered to the feed point

$P_d$  = Power lost

$P_{rad}$  = Power actually radiated

equ<sup>n</sup> (i) can be written as

$$I^2 R_{in} = I^2 R_d + I^2 R_{rad}$$

$$R_{in} = R_d + R_{rad}$$

$$\eta = \frac{R_{rad}}{R_{rad} + R_d} \times 100\%$$

$$R_{rad} + R_d$$

$R_d$  = Antenna resistance

$R_{rad}$  = Radiation resistance

### 2.4.8 Polarization

- The direction of electric field portion of EM wave transmitted by system is referred as polarization.
- It also refers to the physical orientation of radiated waves in space.
- Waves are said to be polarized if they all have the same alignment in space.
- A vertical antenna will radiate waves whose electric vectors will all be vertical and will remain so in free space.
- The best example of randomly polarized field vector is “Light emitted by incoherent sources such as SUN”

### 2.4.9 Attenuation

- Attenuation is happen when the electromagnetic waves are travel outward from their source.
- Attenuation is proportional to the square of distance which is traveled by this electromagnetic waves.
- It is measured in terms of decibels (dB).

## 2.5 Directional High frequency Antenna:-

This antenna has ability to transmission & reception in high frequency range.

### 2.5.1 The Yagi- Uda Antenna

- A Yagi- Uda antenna is an array consisting of a driven element & parasitic elements are arranged close together.
- Since it is relatively unidirectional, as per radiation pattern shows and has a moderate gain in the vicinity of 7dB.
- The Yagi antenna is used as a High Frequency antenna. It can also used at higher frequencies, such as television receiving antenna.
- Here in Yagi-uda antenna the “front-to-back ”ratio is improved, by bringing the radiator closer.
- As a parasitic element is brought closer to the driven element, it will load the driven element more and reduce its input impedance.
- The Yagi antenna admittedly does not have high gain, and used in broadband because of floded dipole used and has quite a good unidirectional radiation pattern.
- Sometimes it is called a supper gain antenna because of its gain and beam width per unit of array.

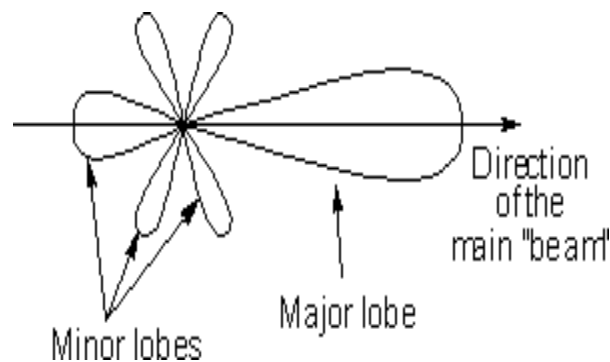

**Fig.2.5** Radiation pattern of Yagi-Uda Antenna

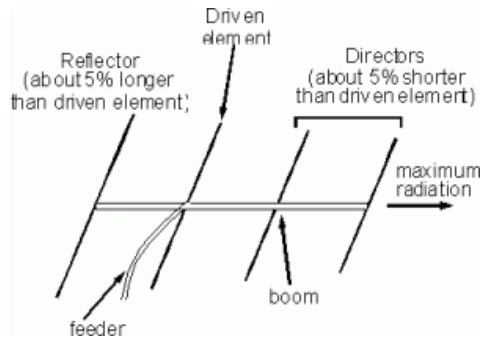

**Fig.2.6** Constructional view of Yagi-Uda Antenna

### 2.5.2 UHF Microwave Antenna

Antenna which are capable of transmitting and receiving in UHF (0.3-3GHZ) & Microwave (1-100GHZ), are termed as UHF & Microwave antenna. These antennas dimension must generally be several wave lengths in order for it to have high gain. These antenna have number of UHF & Microwave applications, such as radar, are in the direction finding and measuring field. Other applications such as microwave communication link and other point to point communications.

## Ch-3. Transmission line

### Introduction to Transmission line

Transmission is referred to the medium through which the RF wave is travel that may be wire oriented or wireless. The circuits used to transmission or propagation of microwave are called transmission lines or otherwise called wave guides. Due to the conventional open wire system is not suitable for transmission of microwave signals because of high transmission losses or radiation losses the transmission lines are employed.

### Multi conductor lines

- Co-axial lines
- Micro strip lines
- Strip lines
- Slot lines
- Co-planer lines.

### Single Conductor lines

- Rectangular wave guides
- Circular wave guides
- Ridge wave guides

### Application

- For propagation of TEM & QUASITEM mode the multi conductor lines are used.
- For propagation of TE & TM mode the single conductor lines are used

### 3.1. Classification of X-Mission lines

- **RF Lines-** To radiate RF energy RF lines are utilized. This may be a parallel wire line.
- **Co-Axial-** The Co-axial lines are employed for frequencies upto 18GHZ or above.
- **Telephone Line twin-** This is based on the parallel wire line. This is never used for microwave application.

### 3.2. Different losses in X-Mission line

There are three losses happen in transmission line may become dissipated before reaching the load.

- Radiation

- Conductor Heating
- Dielectric Heating

### Radiation

- Radiation losses occur because transmission lines act as an antenna if the separation of the conductor is an appreciable fraction of a wave length.
- This applies more to parallel wire lines than to Co-axial lines.
- Radiation losses are difficult to estimate being normally measured rather than calculated.

### Conductor Heating

- It is otherwise known as  $I^2R$  loss.
- It is proportional to current, therefore inversely proportional to characteristics impedance ( $Z_0$ )
- It also increases with frequency, because of skin effect.

### Dielectric Heating

- It depends on voltage across the dielectric & hence inversely proportional to characteristics impedance ( $Z_0$ ) for any power transmitted.
- It again increases with frequency (for solid dielectric lines) because of gradually worsening properties with increasing frequency for any given dielectric medium.
- For free space, however heating of dielectric is almost equal to zero.

### 3.3. Characteristics- impedance

- Any circuit that consist of series & shunt impedances must have an input impedance.
- For transmission line this input impedance will depend on the type of line, its length & the termination at the far end.

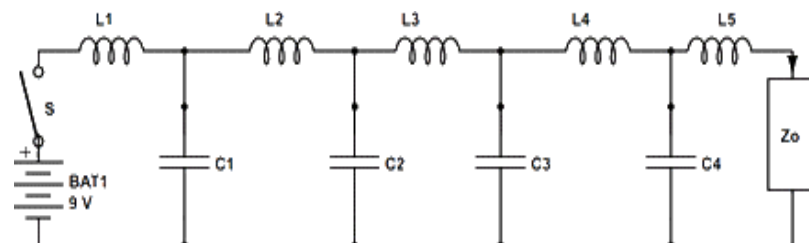

**Fig.3.1.** L-C circuit equivalent of a transmission line

- The input impedance under certain standard, simple and easily reproducible condition is taken as reference is called characteristics impedance.



- The above figure follows from filter theory that the characteristic impedance of an iterative circuit, consisting of series & shunt element is given by

$$Z_0 = \sqrt{Z/Y}$$

$$Z = \text{Series impedance / section}$$

$$= R + j\omega L$$

$$Y = \text{Series admittance per section}$$

$$= G + j\omega C$$

$$Z_0 = \sqrt{(R + j\omega L) / (G + j\omega C)}$$

In case of radio frequencies resistive components of the equivalent circuit become insignificant & the  $Z_0$  reduced to

$$Z_0 = \sqrt{j\omega L / j\omega C} = \sqrt{L/C}$$

$L$  = It is measured in henry's / meter

$C$  = It is measured in farad's / meter

### 3.4. Reflection-Coefficient

Reflection Co-efficient  $\rho$  is defined as the ratio of the electric intensity of the reflected wave to that of the incident wave.

Therefore  $\rho$

$$\rho = \frac{\text{Electric intensity of the reflected wave}}{\text{Incident wave of same wave}}$$

It is unity for a perfect conductor or reflector, and less than for practical conducting surface.

### 3.5. Standing wave ratio (SWR)

- The comparison of maximum current to minimum current along a transmission line is called standing wave ratio, as the ratio of maximum to minimum voltage.
- It is a measure of the mismatch between the load and the line, and is the first and most important quantity calculated load.
- Its value is unity when the load is perfectly matched.
- For a purely resistive load the SWR is given by:  $Z_0/R_L$  or  $SWR = R_L/Z_0$
- For the fully reactive load, SWR will be " $\infty$ ".

### 3.6. Impedance Matching in transmission line

- Impedance matching is based on maximum power transfer theorem.

- Where the as per this theorem resistance of load should be equal to that of the source.
- The load reactance must be equal to that of the source but opposite in sign  
i.e.  $R_L=R_S$  &  $+jX = -jX$
- After the above condition satisfied for a transmission line, the impedance matching can be achieved.
- Generally signal sources have fixed impedance matching reduced to choosing a proper load impedance by some means.
- If the load impedance is also fixed value, then it needs to be transferred to the required matched value by means of a matching network.
- In transmission line system too, this matching becomes important as it is required to achieve, unity, SWR to avoid danger of flash at large value of power, to ensure transmission of a given power with a smaller peak voltage and for obtaining greater transmission efficiencies without reflections.
- Moreover, a property terminated transmission line with its characteristic impedance  $Z_0$  will be non-resonant, i.e. its input impedance remains at the value of  $Z_0$  even when the frequency is varied and it will not load the source.

### 3.7. Stub Matching Techniques

- A stub is a short circuited transmission lines are more often used at very high frequencies.
- Matching at lower Radio frequencies can be done by tuning out the complex load reactance and then transforming the resistive component of the load impedance to a value of equal to the characteristics impedance of the line.
- At higher microwave frequencies this method is not be useful & transmission line techniques like stub matching is employed.
- There are basically two stub matching techniques.
  1. Single stub matching
  2. Double stub matching

#### 3.7.1. Single stub matching

- Here in this method of single stub matching a short circuited stub of length “L” is placed at a distance L from the receiving end impedance  $Z_L \neq Z_0$ .
- At microwave frequencies  $Z_0=R_0$  a pure resistance and at a length **L** from the load, the impedance  $R_1+JX_1$  is such that  $R_1=R_0$  . Now the length ( $l_1$ ) and the position ( $l$ ) of the stub

required for matching are to be found. We know that the input impedance at any point of a transmission line is given by

$$Z_{in} = Z_0 \frac{Z_L + Z_0 \tan \gamma l}{Z_0 + Z_L \tan \gamma l}$$

Converting impedance into admittance, we get

$$Y_{in} = Y_0 \frac{Y_L + Y_0 \tanh \gamma l}{Y_0 + Y_L \tanh \gamma l}$$

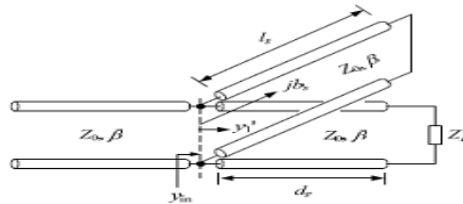

**Fig.3.2** Operational view of a Single Stub Matching

For a high frequency line,  $\alpha=0$  so that  $\gamma=j\beta$ . Also changing admittance into normalized admittance in the above equation we have

$$Y_{in} = \frac{Y_L + j \tanh \beta l}{1 + Y_L \tanh \beta l} \quad \text{where } Y_{in} = Y_{in}/Y_0 \text{ and } Y_L = Y_L/Y_0$$

However there are certain disadvantages of single stub matching

- It is useful only for a fixed frequency since any frequency change requires the location of the stub to be changed.
- It is suitable for open wire system but not suitable for co-axial line because of matching can be achieved by final adjustment of the stub by moving along the line slightly.

### 3.7.2. Double stub matching

It is used to overcome the disadvantage of single stub matching. Here two short-circuited stub whose lengths are adjustable independently but whose position are fixed may be used.

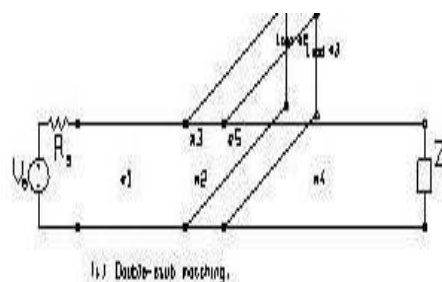

**Fig.3.3** Operational view of Double Stub Matching

Let the first short circuit stub whose length  $l_1$  be located at a point p at a distance of  $l_1$  from the load end. The normalized input admittance is given by

$$\begin{aligned}
 Y_p &= \frac{y_p - y_0}{1 + jy_1 \tan \beta l_1} = \frac{y_1 + j \tan \beta l_1}{1 + jy_1 \tan \beta l_1} \times \frac{1 - jy_1 \tan \beta l_1}{1 - jy_1 \tan \beta l_1} \\
 &= \frac{y_1(1 + \tan^2 \beta l_1) + j(1 - y_1^2) \tan \beta l_1}{1 + y_1^2 \tan^2 \beta l_1} \frac{y_1 \sec^2 \beta l_1 + j(1 - y_1^2) \tan \beta l_1}{1} \\
 &= g_p + jb_p \text{ where } g_p = \frac{y_1 \sec^2 \beta l_1}{1 + y_1^2 \tan^2 \beta l_1}, b_p = \frac{(1 - y_1^2) \tan \beta l_1}{1 + y_1^2 \tan^2 \beta l_1}
 \end{aligned}$$

Where the stub having a susceptance  $b_p$  is added at this point the new admittance will be  $Y_p^* = g_p^* + jb_p$

The total distance  $l + l_2$  should be kept as small as possible to avoid reflection loss occurring the right of generation point Q or at least be kept at minimum. For this reason, the first sub itself should be place at the load.

The double stub can used as a matcher in co-axial microwave lines due to presence of second adjustable position which is not available in single stub matching.

## Ch-4. Microwave Engineering

### 4.1 microwave region and band designation and application of various bands.

- Microwave region in the electromagnetic spectrum along with other frequency ranges as per CCIR recommendations. It may be noted that the beginning of each band is the multiple of tens of previous band.
- Microwave region is varies between 30Hz to 300 GHz of electromagnetic radiation
- This region includes various bands such as Extra low frequency(ELF), Very low frequency(VLF), Low frequency (LF), Medium frequency(MF), High frequency(HF), Very high frequency(VHF), Ultra high frequency(UHF), Super high frequency(SHF), Extra high frequency(EHF).

<b>Band Designation</b>	<b>Frequency Range</b>	<b>Wave length</b>	<b>Propagation Characteristics</b>	<b>Application</b>
ELF (Extra low frequency)	30-300HZ	10-1Mm	Penetration into earth and sea.	Communication with submarine
VLF (Very low frequency)	3-30KHZ	100-10Km	Very low surface wave upto 1000KM low attenuation both during day and night very reliable	Long distance point to point communication
LF (Low frequency)	30-300KHZ	10-1Km	Surface wave and sky wave at night surface wave attenuation greater than VHF	Point to point marine communication, time standard frequency broad cast.
MF (Medium Frequency)	300-3000KHZ	1000-100m	Ground wave during day and in addition sky wave at night. Attenuation high in day time and low at night time.	Broad casting and marine communication.
HF (High Frequency)	3-30MHZ	100-10m	Reflection from ionosphere and varies as per time of day.	Moderate and long distance communication of all types.
VHF (Very high frequency)	30-300MHZ	10-1m	Space wave line of sight.	Television, FM services aviation and police.

UHF (Ultra High frequency)	300-3000MHZ	1000-10cm	Same as VHF affected by tall objects like hills and Towers.	Short distance communication including Radar.
SHF (Super High Frequency)	3-30GHZ	10-1 cm	Same as VHF, UHF suffers atmosphere attenuation above 10GHZ.	Radar, Microwave and space communication.
EHF (Extra High Frequency)	30-300GHZ	10-1 cm	Same as VHF, UHF suffers atmosphere attenuation above 10GHZ.	Radar, Microwave and space communication.

**Table-4.1** List of Various band designations, their frequency range with propagation characteristics and respective application

#### **Advantage of Microwave**

- It increases bandwidth availability
- It improves directive properties
- Due to effect of fading  $\mu$  wave communication is more reliable.
- It helps as in space communication ground station to space vehicle due its transparency property.

#### **Application of Microwaves**

**Tele Communications-** International telephone and TV space communication, telemetry communication link for rail ways.

**Radars-** Detect aircraft observe and track weather patterns, air traffic control etc.

- It also used in commercial and industrial application due to heat property of microwave like in microwave oven, drying machines, food processing industry, rubber and chemical industry etc.
- It also used in identifying objects or personnel by non-contact method.

## 4.2 .Microwave wave guide

- Microwave Waveguide can be defined as a hollow conducting tubes used for transmission of energy in TE and TM modes.
- Waveguide may have rectangular and circular shape is commonly used for transmission of microwave energy.
- The fields which are travel down the wave guide must satisfy the boundary condition imposed by the walls of guide.
- Waveguides are simpler to manufacture than co-axial lines since there is no inner conductor is present in it.
- The power handling capacity of waveguide is more because the non presence of conducting and dielectric material.
- In wave guide the propagation of wave by the reflection from the walls.
- Power loss in wave guide is less compare to transmission lines.
- The main difference between wave guides and transmission line is that a particular mode propagates down a wave guide with low attenuation only if the wavelength of the waves is less than some critical value determine by the dimensions and the geometry of the guide.
- If the wavelength corresponding to the operating frequency is greater than this critical cut-off value, the waves in the wave guide die out rapidly in amplitude even if the walls of guide have infinite conductivity.
- In case of transmission lines, wavelengths greater than cutoff wave length is passed.

### 4.2.1 Rectangular wave guide (operation and advantages)

- It is similar to a transmission line.
- Here an antenna at one end which generates electromagnetic waves, which travel down the wave guide to be eventually received by the load.
- The walls of wave guide are conductors and therefore reflections from them take place.
- When the top and bottom walls are added to our parallels plane wave guide. The result is the standard rectangular wave guide used in practice.
- The two new walls do not really affect any of the results so far obtained and are not really needed in theory.
- In practice their presence is required to confine the wave.

- A familiar trans electro-magnetic wave (TEM) which has the electric field and magnetic field and the direction of propagation mutually perpendicular, and cannot propagate within a single conductor hollow waveguide.
- This is due to the electric field would be short circuited by the walls of wave guide since the walls of wave guide is perfect conductor and no potential can exist between them.

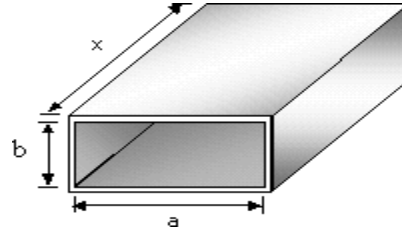

**Fig.4.1** Cross section view of Rectangular wave guide

#### **Advantage**

- It is simple to manufacture than co-axial lines
- Due to there is no inner conductor or the supporting dielectric in a wave guide, therefore the power handling ability of wave guide improve.
- Power losses in wave guide are less than the other transmission line.
- It has mechanical simplicity and a much higher operating frequencies.

#### **Propagation of EM wave through the wave guide with TE & TM modes**

- The electromagnetic wave inside a wave guide has an infinite number of patterns which are called modes.
- It should be known that the electromagnetic wave consists of magnetic and electric field which are always perpendicular to each other.
- In general, there are two kinds of modes in a wave guide.
- In the first type, the electric field is always transverse to the direction of propagation is called the transverse electric or TE mode.
- In the second type, the magnetic field always transverse to the direction of propagation and is called transverse magnetic or TM mode.
- The above modes having two sub-modes such as  
 $TE_{m,n}$  for the transverse electric mode.  
 $TM_{m,n}$  for the transverse magnetic mode.



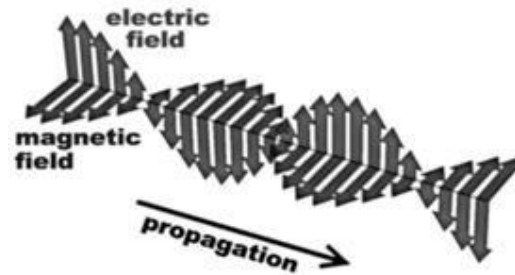

**Fig.4.2** Propagation of TE and TM waves

#### 4.2.2. Circular wave guide

- It operates in same way of rectangular wave guide.
- It is different in geometrical shape and microwave application.
- The propagation of wave in circular wave guide is similar to propagation of wave in rectangular wave guide.
- But the formula for cutoff frequency must be different because of differ in geometrical shape and it is given by

- $\lambda_0 = \frac{2\pi a}{M_a}$

( $M_a$ )

$a$ = radius of wave guide

( $M_a$ )= solution of a Bessel function equation.

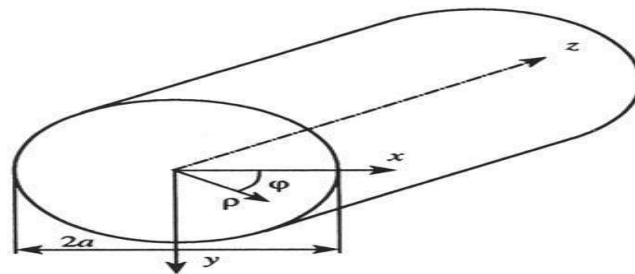

**Fig.4.3** Cross section view of Circular wave guide

#### Advantage

- It is easy to manufacture circular wave than rectangular wave guide.
- The coupling of circular wave guide is easier than rectangular wave guide.
- It became significant if longer distance wave guide transmission is considered.

#### Disadvantage

- The main disadvantage associated with a circular wave guide is that its cross section will be much bigger in area than that of rectangular wave guide used to carry same signal.

## 4.3 Microwave resonators & components

### 4.3.1 Cavity Resonators

- Cavity resonator is a piece of wave guide closed off at both ends with metallic planes
- Here the wave can propagate in longitudinal direction.
- The structure is either hollow or filled with dielectric material in the microwave region of the spectrum
- There is many similarity with a resonant circuit with externally low loss to cavity resonator..
- The completely enclosed wave guide has become a cavity resonator with its own system of mode and therefore resonant frequencies.
- It is thus seen that an space enclosed by conducting walls must have one frequency at which the conditions described for resonator is satisfied, in other word it can say that any such enclosed space must have one resonant frequency.
- Each cavity resonator has an infinite number of resonant frequencies.
- The TE & TM mode numbering system break down unless the cavity has a very simple shape.
- The simplest cavity resonators may be spheres, cylinders or rectangular prism .There is a major drawback is associated with these shapes.
- This is due to when a pulsed energy is fed to the structures of cavity, and the cavity is maintained in sinusoidal oscillation due to flywheel effect and the pulsed energy which contains harmonics which is fed to cavity therefore there is oscillation takes place at harmonics frequencies.
- The result which is in the form of shapes are come out are in odd shapes which ensure that various oscillating frequencies are not harmonically related.

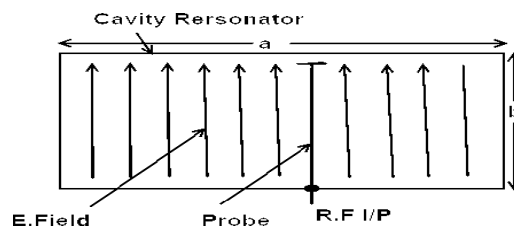

**Fig.4.4** Propagation of Electric field in  $TE_{1,0}$  mode to oscillating the resonator in  $TE_{1,0,1}$  mode

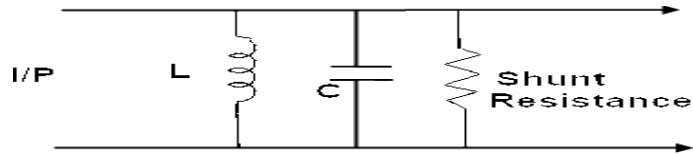

**Fig.4.5** L-C equivalent circuit of Cavity resonator

**Application**

- It is used as a cavity wave meter for microwave frequency measuring device.
- This used in filter circuits or used in co-junction with mixers.
- It is used as a cavity wave meter for measuring of microwave frequency.

**4.3.2 Directional Coupler**

- It is a combination of number of coupling units to measure the power which is delivered from an antenna to load through a transmission line.
- The most popular directional coupler is two-hole directional coupler.
- In the two hole directional coupler it consist of a piece of transmission line to be connected in series with the main line, together with a piece of auxiliary line coupled to the main line via two probes through slots in the joined outer walls of the two co-axial lines.
- The probes do not actually touch the inner conductor of the auxiliary line.
- The probes induce energy flow in the auxiliary line which is mostly in the same direction as in the main line.
- The principle of operation of two hole directional coupler is:

It consist of two guides the main and the auxiliary with two tiny holes common between them as shown in figure

- The two holes are at a distance of  $\lambda/4$  where  $\lambda$  is the guide wave length.
- The two hole 1&2 both in phase at the position 2<sup>nd</sup> hole and hence they add up contributing to p<sub>r</sub>.

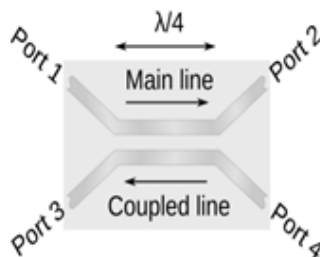
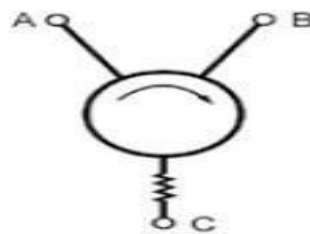

**Fig.4.6**Operational view of Directional coupler

- The magnitude of the power coming out of two holes depends upon the dimension of the two holes.
- Since distance between two holes is  $\lambda/4$ ,  $P_b$  mode „0“ when it come back from hole 2 results  $180^\circ$  phase shift, compared to incident power leakage through hole 1 entering port 3.
- The number of holes can be one or more than two. The degree of coupling is determined by size and location of the holes in the wave guide walls.
- Although degree of directivity can be achieved as a fixed frequency, it is summarized that the frequency determines the separation of the two holes as a fraction of wave length.

### 4.3.3 Isolators

- As isolator is a two port device which provides very small amount of attenuation for transmission from port 1 to port 2. But provide maximum attenuation for transmission from port 2 to port 1.
- In many microwave generators, the output amplitude frequency tends to fluctuate very significantly with change in load impedance.
- This is due to mismatch of generator output to the load resulting in reflected wave from load.

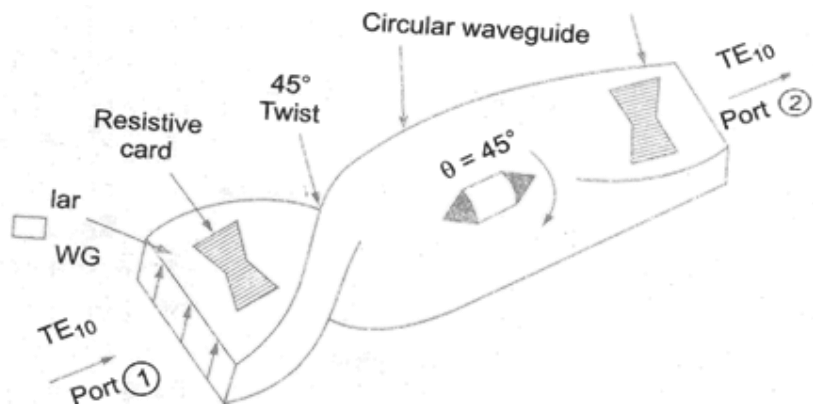

**Fig-4.7** Basic operation of Microwave isolator

- When isolator is inserted between generator and the load, the generator is coupled to the load with 0 attenuation and reflections if any from the load side are completely absorbed by the Isolator without affecting the generator output.

### Operation

- A TE<sub>10</sub> wave passing from port 1 through the resistive card and is not attenuated. After coming out of the card, the wave gets shifted by  $45^\circ$  because of the twist in anti clock wise direction because of the ferrite rod and hence comes out of the port 2 with the same polarization as port 1 without any attenuation.
- But the TE<sub>10</sub> wave fed from port 2 gets a pass from the resistive card near port-2 since the plane of polarization of the wave is perpendicular to the plane of the resistive card.

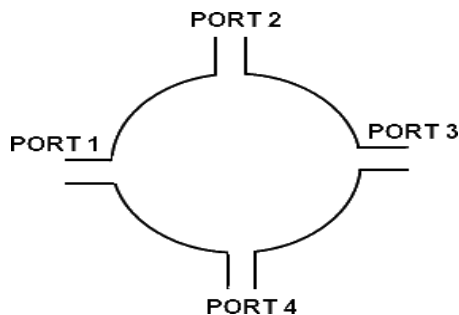

**Fig-4.8** Construction of Microwave isolator

- Then the wave gets rotated by  $45^\circ$  due to Faraday rotation in clockwise direction and further gets rotated by  $45^\circ$  in clockwise direction due to the twisting action of the waveguide.
- Now the plane of polarization of the wave will be parallel with that of the resistive card and hence the wave will be completely absorbed by the resistive card and output at port 1 will be zero.
- This power is dissipated in the card as heat.

#### 4.3.4 Circulators

- A circulator is a four port microwave device which has a peculiar property.
- That is each terminal is connected only to the next clockwise terminal.
- Like port one is connected to port two only and not to port three, four & port two is connected only to port three etc.
- There is no restriction on the number of ports but four ports are most commonly used.



**Fig.4.9** Operational view of 4 port circulator

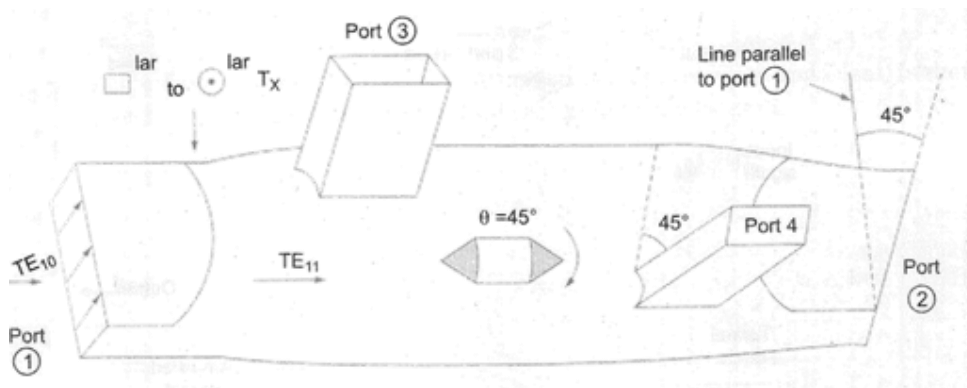

**Fig-4.10** Construction of Microwave circulator

### Operation

- When the power entering at Port-1 is TE<sub>10</sub> mode & is converted into TE<sub>11</sub> mode because of gradual rectangular to circular transition.
- This power passes port-3 unaffected since the electric field is not significantly cut and is rotated through 45° due to the ferrite, passes port-4 unaffected and finally emerges port2.
- The power fed to port 2 will behave just like the port2 of isolator, but
- In this case of circulator it is rotated so that it still cannot come out of port 1, but it align with port 3 and emerges from it.
- Similarly the port 3 is only coupled to port 4 and port 4 is only coupled to port 1.
- The power limit of 4 –port circulator is same extent as in the Faraday rotation isolator.
- High power circulator are fairly similar to the resonance isolator, and it can handle a power limit up to 30 Megawatt.

### Application

- It can be used as a duplexer for a radar antenna system.
- It can also be used as low power devices as they can handle low power only.

## 4.4 Microwave tubes & Circuit

The limitation of conventional negative grid tubes are electron transit time which becomes a noticeable proportion at high frequencies. There are some severe limitations on conventional tubes which make their operation relatively poor at UHF & VHF.

### 4.4.1. Two cavity klystron

- It is basically a velocity modulated tube, in which the velocity modulation process produces a density modulated stream of electrons.
- Here a high speed electron beam is formed and focused, sent down along a glass tube through an input cavity (buncher) a field free drift space and an output cavity (catcher) to a collector electrode / anode.
- Here magnetic focusing is employed.
- The Anode should be kept at a +ve potential with respect to cathode.
- The electron beam passes through a gap consisting of two grids of the buncher cavity separated by a very small distance and two other grids of the catcher cavity with another small gap.
- The advantage of two cavity klystron is the relatively high CW power of which they are capable as compared to their small size.
- The biggest drawback associated with it i.e. it requires two cavities and each has to be retuned separately if a frequency change is required.

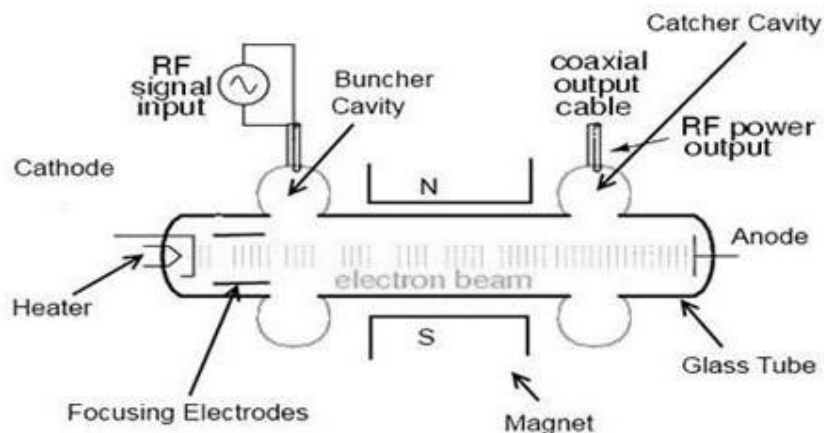

**Fig.4.11**Operational view of Two Cavity Klystron

## **Operation**

- The RF signal to be amplified is used for exciting the input buncher cavity there by developing an alternating voltage of signal frequency across gap.
- The velocity of electron varies in accordance with RF input voltage, resulting in velocity modulation of the electron beam.
- As a result of this action, the electron in the bunching limit gradually bunch together as they travel down the drift space, from gap to small gap. The pulsating stream of electrons passes through small gap and excites oscillations in the output cavity (catcher).
- The density of electron passing the small gap very cyclically with time, i.e. the electron beam contains an ac current and is current modulated.
- The velocity modulation is converting into current modulation due to this drift space.
- Bunching occurs only once per cycle centered around the reference beam.

## **Application**

- The two cavity klystron oscillator is used as power oscillator in the frequency range from 5 to 50 GHz, with output power ranging from 2 to 10W.
- The main application of this two cavity klystron is in CW Doppler Radar, for pumping parametric amplifiers.
- It also used as a frequency modulated oscillator in high power microwave links.

### **4.4.2 Magnetron**

- The cavity magnetron is a high power microwave oscillator.
- Its behavior is similar to a diode which uses the interaction of magnetic and electric fields in a complex cavity to provide oscillations of very high peak power.
- The cavity magnetron which is referred as the magnetron usually of cylindrical structure.
- It follows a electric field, an axial magnetic field and an anode structure with a permanent cavities.
- The magnetic field which is of axial has lines of magnetic force passing through the cathode and the surrounding interaction space.
- The output is taken from one of the cavities by means of a co-axial line as indicated in figure or through a waveguide, depending on the power and frequency.



- The output coupling loop leads in a cavity resonator to which a wave guide is connected, and all the overall output from this magnetron is via wave guide.

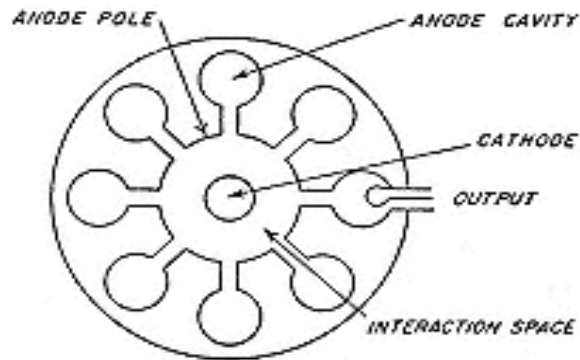

**Fig.4.12** Cross section view of Microwave Magnetron

- The magnetron has a number of resonant cavities and must therefore have a number of resonant frequencies and modes of oscillation.
- The rings interconnect the anode poles are used for strapping and reason for their presence.
- Anode is normally made of copper for getting right shape and size.
- Anode poles should be kept at  $45^\circ$  and phase shift should be  $360^\circ$ .
- The phase difference between anode and poles is  $180^\circ$ .

### Effects of magnetic field

- When electron are emitted by the magnetron cathode will under the magnetic field as well as electric field.
- The behavior of electron in the magnetic field must be known.
- If the electron moving horizontally and the magnetic field act as vertically the path of electron is in curve shape.
- The magnetic field in the magnetron is constant and the force of magnetic field on the electron will depend slowly on forward velocity of the electron.
- When magnetic and electric field act simultaneously upon the electron its path can have any no of shapes directed by the relative strengths of mutually perpendicular electric and magnetic fields
- When the magnetic field is zero the electron goes straight from the cathode to the anode accelerating all the time under the force of the radial electric field

- As the electron approaches the anode its velocity continuously to increase radially as it is accelerating.
- The effect of the magnetic field upon it increases so that the path curvature become sharper of the electron approaches the anode
- It is possible to made the magnetic field so strong that the electron will not reach will the anode at all.
- The magnetic field require to return electrons to the cathode after they have just grazed the anode is called cot out field
- If the magnetic field is still stronger the electron path will be more curved and the will be return to the cathode very soon
- All the paths are naturally changed by the presence of any radio frequency field due to oscillation which leads oscillating the magnetron.

#### **4.4.3. Travelling Wave Guide**

- Travelling Wave Guide is a linear beam tube used as a microwave amplifier.
- It is the device in which the interaction between the beam and radio frequency field is happen.
- Its main application is used for medium and high power amplifier.
- The RF field propagates with the velocity equal to the velocity of light.
- According to principle of TWG the interaction between electron beam and the RF necessary to ensure that both are moving the same direction with approximately same velocity
- The interaction between RF field and the electron beam will takes place only when the velocity of RF field is retreated.
- This relation is quite different from the multi cavity klystron in which the electron beam travels but the RF field is stationary.

#### **Construction**

- It contain a electron gun , as used in klystron is used to produce narrow electron beam ,which in turn is passed through the centre of a long axial helix.
- A magnetic focusing field is provided ,to prevent the beam from spreading and to guide it the center of helix.

## 4.5 Microwave measurements

In microwave communication there is a need of measurement of power, the power of frequency is need to be measured .The power measurement must be done for lower microwave frequency and also for medium &high microwave frequency.

For the microwave power measurement there is a need of measurement of voltage and current to calculate it. At high audio and low radio frequencies, power often calculated and not measured .As frequency increases to the microwave region of the frequency spectrum where transmission lines and waveguides are employed, current and voltage remain no longer. The most of the microwave measuring device measure the average power and expressed in terms of joules per second or watt. The methods of microwave power measurement is given below

### 4.5.1 Bolometer method

- A bolometer is a simple circuit element whose resistance varies with a change in temperature.
- There is two different element coming under this above category such as the barretter and the thermistor. Barretter is just like a wire mounted in a cartridge like ordinary fuse and its resistance increases with increase in temperature.
- But the property of thermistor is just reverse of barretter as its resistance decrease in increase in temperature.
- The bolometer device can be used in a balanced bridge to calculate RF power.
- Just like crystal diode, a bolometer is a square law device and it produces a current that is proportional to the applied power rather than the applied voltage.
- It can easily mounted in wave guide or co-axial mounts.
- For practical point of view of bolometer measurement it can be connected the wave guide and used as a load, any mismatch is turned out and change in resistance which is due to microwave power dissipation is used to indicate the power level.
- In this method the bolometer is connected in one of the arm of the wheat stone bridge for microwave power measurement.
- Wheat stone bridge method of bolometer power measurement

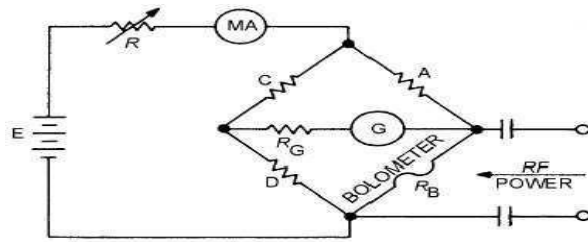

**Fig.4.14** Wheatstone bridge arrangement of Bolometer measurement of RF power

- Here in the above figure A,  $R_B$ , C, D are connected in four arms of wheat stone bridge, and the RF power is to be measured is applied to the bolometric arm  $R_B$ .
- Initially the bridge is balanced by an adjustment of resistance R which varies the d.c. power applied to the bridge, therefore the resistance of the  $R_B$  that resistance of the thermistor when there is no microwave frequency.
- When RF power is applied the bridge is under go unbalance, and the resistance of the thermistor changes.
- At this case either two methods can be adopted: First one is “the applied d.c. power is changed until the bridge is again in balance or else the current of the galvanometer is converted into microwave power reading”. In the second case “it is possible to calculate the d.c. power change by multiplying the applied d.c. voltage by the change in current.
- The galvanometer reading can be calibrated directly in miliwatts to measure supplied RF power.

#### 4.5.2 Calorimeter Method For Power Measurements

- This is used for measurement of medium to high microwave power measurement.
- It is a direct and basic power measurement calculated from the temperature rise of a special load. This load should be have high specific heat such as water.
- If we know the mass, specific heat and temperature rise at at a fixed and known rate of fluid flow or rate of temperature rise with a fixed quantity of fluid, the power may be calculated.
- In this method we do not require the measurement of flow rate of fluid but we assume it is constant and is same for both the microwave and the sixty cycles heating of the fluid.
- Water flow systems may be open or closed flow type . In former type of system a constant head is maintained by means of an elevated reservoir kept at a constant level by an over flow system.

- Water from this reservoir discharged at a constant rate of flow through the micro wave water load. Additional equipment includes means for bringing the water to ambient temperature before passing it to the microwave water load, a bubble trap and a flow meter.

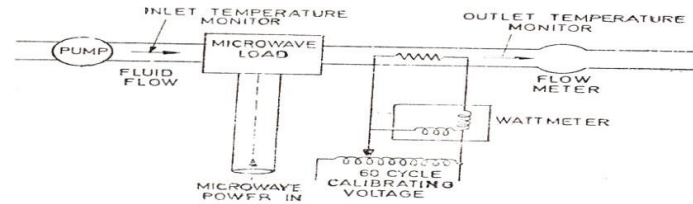

**Fig.4.15** Operational view of Calorimeter method of RF power measurement

- In the latter type system the water is circulated by help of a motor driven pump through the microwave load into cooling coils and back through the system again.
- The use of calorimeter measurements has a disadvantage of thermal inertia which causes a time lag between the application of microwave power and the final readings.

#### 4.5.3 Measurement of frequency

- In all microwave calculations frequency is the most fundamental quantity required, which depends only on the properties of the signal source and does not change as wavelength when travelling through wave guide .
- The wavelength depends upon the velocity factor and the electromagnetic field configuration as well as the input frequency so that it varies from points to point.
- For microwave application the customary frequency of about 5 MHz of such an oscillator must be multiplied with a help of varactor chain. This results a microwave frequency source having a fixed frequency and a stability to a few parts in  $10^{-9}$ . This may be used to calibrate a good generator at a single point or at several if different multiplication factors of the initial frequency are available.
- For ordinary laboratory measurement cavity wave meters are used to measure frequency.

#### 4.5.4 MEASUREMENT OF WAVE LENGTH

- A general method of measuring free space wavelength is by calculation from frequency determination by using the formula

$$\lambda = c/f$$

- This method is good for most of the application, but it is limited in accuracy by an error value of the free space velocity of light, which is about 2 parts in  $10^{-6}$ .

#### **4.5.5 Measurement of Attenuation**

- Attenuation is defined as a ratio of power between two points along a transmission line. It can be expressed in terms of decibels (dB).
- It can be measured under matching conditions; otherwise it cannot measure accurately due to power reduction in mismatch network and how much is due to attenuation of the network.
- It can be found from power ratios under matched conditions
- The most common methods are used for measurement of Attenuation in a matched network are
  - Power ratio method
  - Substitution method

##### **4.5.5.1 Power Ratio Method For Measurement Of Attenuation**

- Here in power ratio method the attenuation can be calculated by the comparison of power of two networks with full load condition of one network to no load condition of second network.
- In this method of attenuation measurement firstly the power is measured which is delivered to the first network consisting of load.
- Then after power is measured of the second network without consisting of load whose attenuation is to be determined.
- After power is measured for both the network, then the attenuation can be calculate from the ratio of power of second network to power of first network.
- If the attenuation of the network will remain high, then different methods of power measurement will have to be used for two powers, with taking care to avoid errors produced due to this.

##### **4.5.5.2 Substitution Method For Measurement Of Attenuation**

- This method is used for measurement of attenuation of a network.
- It is adopted when there is input power to a network is low and it has a high attenuation.
- This is a simple method in which output power from the common network is measured.

- This network is replaced by a calibrated attenuator which is adjust until output power is remain same
- Under the condition the attenuation of the two networks is the same and can be read off from the calibrated attenuator.

#### 4.5.6. VSWR Measurement

- VSWR method is used to determine the cavity Q .
- In impedance measurement system the half power frequencies can determined .There is a problem
- Arises when the setting of standing wave in the line which feeds the resonator is related to equivalent cavity impedance in which the line is terminated.
- This half power frequency can measure directly by the VSWR measurement.
- The half power frequencies are those frequencies at which the equivalent resonator reactance is equal in magnitude to the equivalent resonator resistance.
- This is based on the low frequency equivalent of a series RLC circuit connected with a zero impedance source.

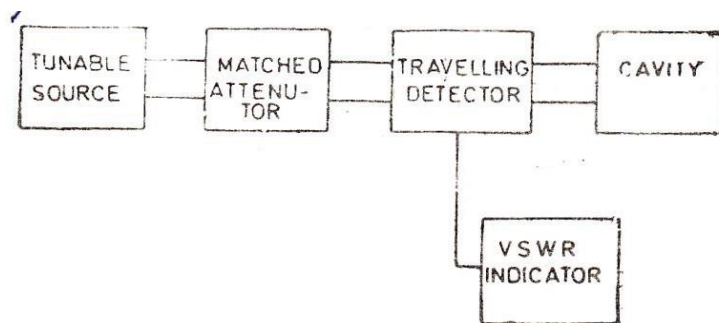

**Fig.4.16** Block diagram representation of VSWR arrangement

- From the transmission line theory it is known that VSWR produced by a terminating impedance  $Z_r$  in a loss less line of characteristic impedance  $Z_0$  is given by

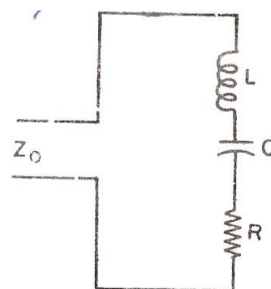

**Fig.4.17** L-C equivalent circuit of Characteristic impedance  $Z_0$

$$VSWR = S = \frac{|Z_r + Z_0| + |Z_r - Z_0|}{|Z_r + Z_0| - |Z_r - Z_0|} \quad (1)$$

- For a suitable reference plane, a cavity may be represented by a equivalent series RLC circuit near any resonant frequency.
- For this series RLC circuit the line is terminated with series impedance  $Z_r = R + jX$ .
- At resonant frequency  $f_r$ , i.e. when reactance  $X=0$ , the above equation reduced to  $S_r = R/Z_0$  if  $R > Z_0$  -----(2)
- $S_r = Z_0/R$  if  $R < Z_0$ ----- (3)

$$S_{1/2} = \frac{\sqrt{(R+Z_0)^2 + R^2} + \sqrt{(R-Z_0)^2 + R^2}}{\sqrt{(R+Z_0)^2 + R^2} - \sqrt{(R-Z_0)^2 + R^2}} \quad (4)$$

At half power frequencies of the unloaded cavity, at which  $X=R$ , then the equation (1) becomes

$$\left. \begin{aligned} S_{1/2} &= S_r + \frac{1}{2S_r} + \sqrt{S_r^2 + \frac{1}{4S_r^2}} \quad \text{when } R > Z_0 \\ S_{1/2} &= \frac{1}{S_r} + \frac{S_r}{2} + \sqrt{\frac{1}{S_r^2} + \frac{S_r^2}{4}} \quad \text{when } R < Z_0 \end{aligned} \right\} \quad (5)$$

- For determining the unloaded Q of the resonator, the VSWR producer by the unloaded resonator is measured over a frequency range centered at the resonant frequency.
- The curve plotted between VSWR vs. frequency which indicates the value of S occurs at resonance , therefore the minimum value of curve is  $S_r$  .

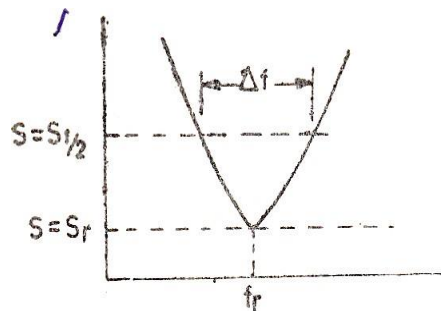

**Fig.4.18** Plotting of graph between VSWR vs half power frequency

- The value of  $S_{1/2}$  is plotted on the curve to get half power frequencies.
- The difference between the two half power frequencies is  $\Delta f$ . The resonator unloaded Q can be determined from the relation
- $Q = \frac{f}{\Delta f}$  .



- When the resonator is loaded, the equivalent resonator resistance  $R$  which appears in eqn-5 is substituted by a resonator resistance and an equivalent load resistance.
- The loading in the resonator changes the minimum value  $S_r$  of the curve and makes the curve less steep thereby the value of  $\Delta f$  is increased by loading and leads to the expected lower value of  $Q$ .
- Because of the greater accuracy with which the larger value of  $\Delta f$  can be measured.

## 4.6 Microwave solid state device

### 4.6.1 Varactor diode

- The term "Varactor" referred to the voltage variable capacitance of a reverse biased junction.
- They have non-linearity of capacitance which is fast enough to follow microwaves.
- It is a semiconductor device in which the junction capacitance can be varied as function of the reverse voltage of the diode.
- With a reverse bias, the junction depleted by mobile carriers resulting capacitance i.e. the diode behaves as a capacitor with the junction acting as a dielectric between two conducting materials.
- The width of depletion region increases with reverse bias and the capacitance decreases as the reverse bias increases

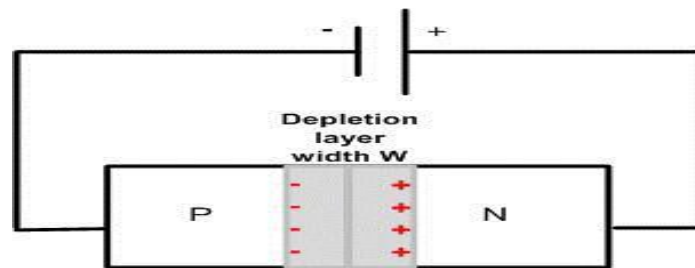
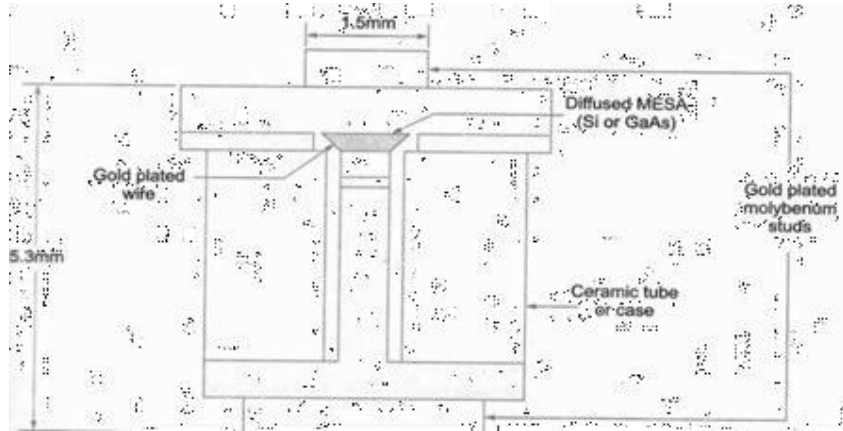

**Fig.4.19** Cross section view of P-N junction of Varactor diode

### Construction of Varactor Diode

- The diode encapsulation contains electrical lead attached to the semiconductor wafer and a lead to the ceramic case.
- Diffused junction MESA sid diodes are widely used at microwave frequencies.

- They are capable of handling larger powers and large reverse break down voltages and have low noise.
- Frequency limit of silicon diodes upto 25GHZ varactors are made of GaAs have high operating frequency i.e. above 90GHZ and better functioning at the lowest temperature



**Fig.4.20** Layout of varactor diode

### Operation

- At microwave frequencies  $R_j$  is the order of  $10M\Omega$  and may be neglected compared to capacitive reactance.
- The diode encapsulation contains electrical leads attached to the wafer and low loss ceramic cases as a mechanical support to the wafer.
- When the varactor is under dynamic condition i.e. when the junction capacitance value varies because of the applied voltage and frequency  $f = \omega/2\pi$ , the capacitance value varies as the instantaneous value of the signal and hence it is taken as the time dependent non-linear capacitance.

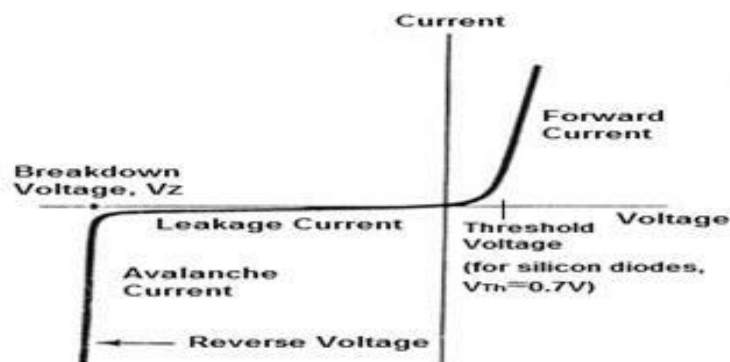

**Fig.4.21** Characteristic curve of Varactor diode

## Application

- For Harmonic generation
- For Microwave frequency multiplication.
- For low noise amplification.
- For active filters.
- For pulse generation and shaping

### 4.6.2. Gunn diode

- The Gunn diodes are grown epitaxial out of GaAs or InP doped with silicon, tellurium or selenium.
- For ohmic contact the substrate used is highly doped for good conductivity while the thin active layer is less heavily doped.
- The gold alloy contacts are electro deposited and used for good ohmic contact and heat transfer for subsequent dissipation.
- The thickness of active layers of diodes may vary about 40  $\mu\text{m}$  to about 1  $\mu\text{m}$  at highest frequencies.

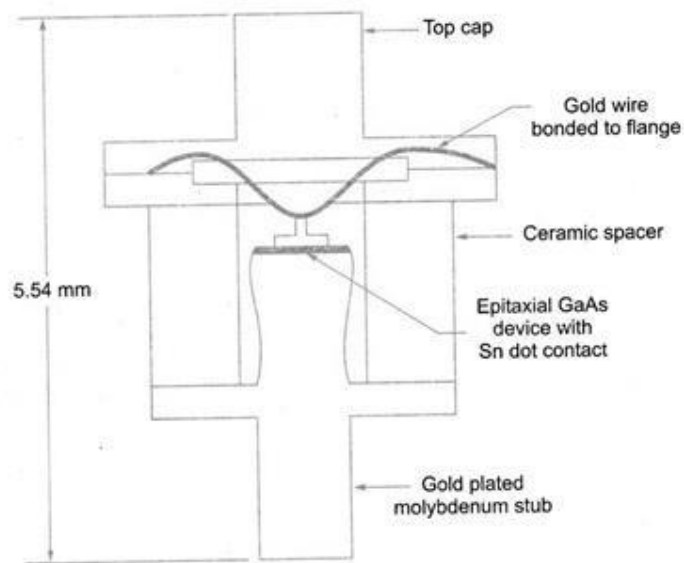

**Fig.4.22** Layout of Gunn diode

## Operation

- The Gunn diode has characteristics (I-V) that shows a negative differential resistance that can be used to generate RF power from Direct Current.
- Its operation is based on the *Transferred electron effect* which in terms known as *Gunn effect*.
- The equivalent circuit of GaAs X- band Gunn diode consists of a negative resistance of about  $100\Omega$  in parallel with a capacitance about 0.6 PF.
- Such a commercial diode will require a 9 Vdc bias and with an operating current of 950mA, the dissipation in its heat sink will be 8.55w.
- A higher frequency Gunn diode, operating over the range of 26.5 to 40GHZ, might produce an output of 2.5 w.
- Gunn diodes can produce continuous power up to several hundred milliwatts, at frequencies from 1 to 100 GHz with efficiencies ranging from 5% to 15% .

## Application

- Used in radar transmitters.
- Used in Broad band liner amplifier.
- Used in Traffic radar system.
- Used in Motion detector in security services.
- Used for fast combinational and sequential logic circuit.
- Used as pump sources in parametric amplifier

### 4.6.3. PIN Diode

- The PIN diode consisting of a thin layer of P-type semiconductor separated from an equally thin layer of n-type material by a somewhat thicker region of intrinsic material.
- Gallium arsenide is used in the construction of PIN diodes, silicon tends to be the main material.
- The reasons for this are easier fabrication, higher power handled and higher resistivity of intrinsic region.



**Fig.4.23** Cross section view of PIN diode

## Operation of PIN diode

The operation of PIN diode is in 3 biasing condition.

**Zero bias:** - At Zero bias the diffusion of the holes and electrons across the junction causes space charge region of thickness inversely proportional to the impurity concentration.

**Reverse bias:-** At reverse bias, the space charge region in the p and n layers will become thicker. The reverse resistance will be very high and almost constant.

**Forward bias:-** At forward bias condition the forward bias carriers will be injected into „I“ layer and the P & N space charge region will become thinner i.e. electron & holes are injected into „I“ layer from P&N layers respectively. This results in the carrier concentration in the „I“ layer becoming raised above equilibrium levels and the resistivity drops as forward bias increases.

Thus low resistance is offered in the forward direction.

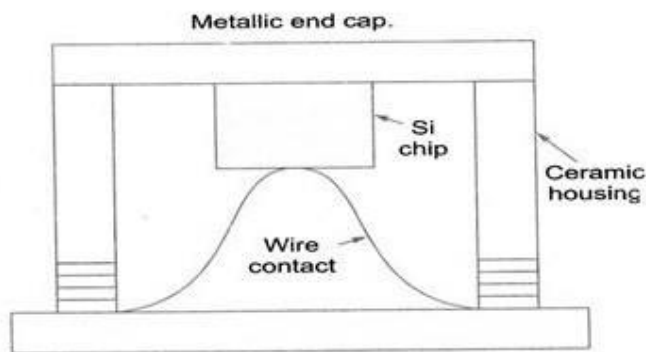

**Fig4.24** Layout of PIN diode

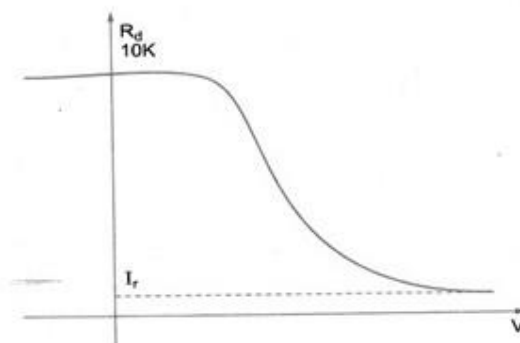

**Fig.4.25** Characteristics curve of PIN diode

### Application of PIN diode

- It can use as a RF switch.
- Can be used as a amplitude modulator.
- Can be used as a phase shifter.
- Can be used as a limiter.

### 4.6.4 MASER (Microwave Amplified Stimulated Emission of Radiation)

- Its principle is based on the quantum theory of physics.
- It is highly directional have co-herent power with extremely low noise figure.
- Maser is a new approach for conversion of atomic energy into electromagnetic energy and also termed as “Molecular Amplification by Stimulated Emission of Radiation”.

### Operation

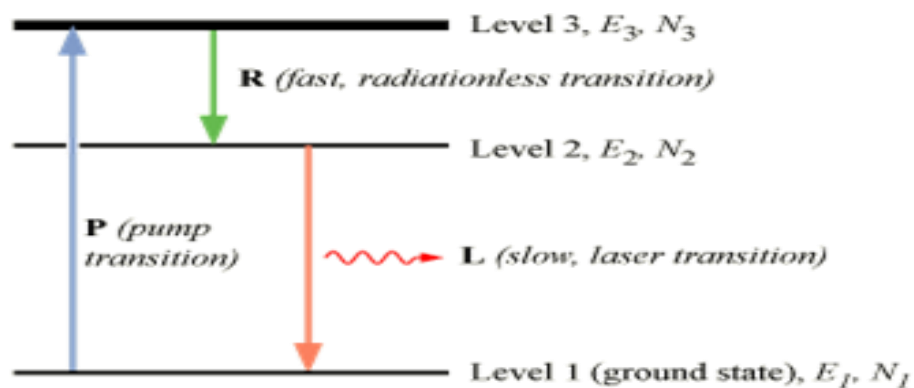

Fig.4.26 Basic operation of MASER

- The electrons belonging to the atom of substance can exist in various energy levels corresponding to different orbit shells for the individual atoms.
- At a very low temperature, most of the electron exists in the lowest energy level, but they jump from lower energy level to higher energy level by getting some amount of energy.
- The electron which is excited to higher energy level is coming back to ground state by emitting a energy called photons.
- The re emission of energy has been stimulated at the expense of absorption. This may done by such measures as the provision of a structure resonant at the desired frequency and the removal of absorbing atoms as done in gas maser.
- When supply to the atoms is done at particular frequency, they are raised up to an energy level which is much higher than the ground state.

- This is make the atom emits energy at a frequency corresponding to the difference between the top level and ground level.
- Pumping occurs at the frequency corresponding to the energy difference between ground and top level.
- Re emission of energy is stimulated at the desired frequency and the signal at this frequency is amplified.

### Application

- Used as a low noise low level amplifier.
- It is suitable for radio astronomy and the other extra-terrestrial communication.
- Used as in Radio telescopes and space probe receivers.

### 4.6.5. LASERS (light amplification by stimulated emission of radiation)

- Laser is the device is defined as highly monochromatic, coherent source of optical radiation.
- Laser is a source of coherent EM waves at infrared and light frequencies.
- It also analogues to an electronics oscillator, which is a source of electromagnetic waves in the lower frequency, range of the electromagnetic spectrum.
- Its working principle is similar to MASER.

The working principle of LASER is as follow

- When light is incident on a medium, the atoms in the lower energy level is excited higher energy level after absorbing the energy of light which is incident.

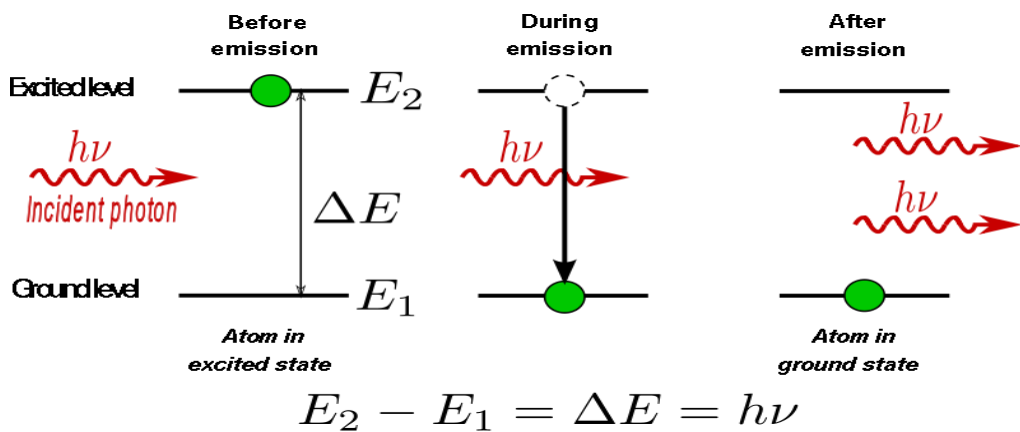

Fig.4.27 Basic LASER operation

- The atoms present in higher energy level come to lower energy level by emitting some radiation; this is known as spontaneous emission.
- The process stimulated emission is takes place, when radiation of suitable energy is incident of excited atoms, where excited atoms comes down to lower energy state by emitting radiation called photons along with the incident radiation.
- In the above process tow photons are produced having some phase and frequency.
- If the number of these photons can be increased, then intense beam of Co-herent light may be produced.
- For a given medium there may be several spontaneous emission and stimulated emission is occur, whereas the stimulated emission is takes place more times than the spontaneous emission which in turn dominant it.

### **Application**

- Used as a source of information in optical fiber communication.
- Used as a source in microwave communication.