

# **C. V. Raman Polytechnic**

**DEPARTMENT OF MECHANICAL ENGINEERING**

## **THERMAL ENGINEERING-II LECTURE NOTES**

**Prepared By**

*Dr. Shubhashree Mohapatra*

*Assistant Professor in  
Mechanical Engineering  
CVRP, Odisha*

# **CHAPTER-1**

## **PERFORMANCE OF I.C. ENGINE**

### **INTRODUCTION**

- With a growing demand for transportation IC engine have gained lot of importance in automobile industry.
- It is therefore necessary to produce efficient and economical engines. While developing an IC engine it is required to take in consideration all the parameters affecting the engines design and performance.
- There are enormous parameters so it becomes difficult to account them while designing an engine. So it becomes necessary to conduct tests on the engine and determine the measures to be taken to improve the engines performance.

### **OBJECTIVE**

- To understand the performance parameters in evaluation of IC engine performance,
- To calculate the speed of IC engine, fuel consumption, air consumption, etc.,
- To evaluate the exhaust smoke and exhaust emission.

### **PERFORMANCE PARAMETERS**

1. Power and Mechanical Efficiency
2. Fuel Air Ratio
3. Volumetric Efficiency
4. Specific Output and specific weight
5. Specific Fuel Consumption
6. Thermal Efficiency and Heat Balance
7. Exhaust Smoke and Emissions
8. Effective Pressure and Torque

The particular application of the engine decides the relative importance of these performance parameters.

For Example: For an aircraft engine specific weight is more important whereas for an industrial engine specific fuel consumption is more important.

### **Power and mechanical efficiency**

- An IC engine is used to produce mechanical power by combustion of fuel. Power is referred to as the rate at which work is done. Power is expressed as the product of force and linear velocity or product of torque and angular velocity. In order to measure power one needs to measure torque or force and speed. The force or torque is measured by Dynamometer and speed by Tachometer.
- The power developed by an engine and measured at the output shaft is called the **brake power (bp)** and is given by,

$$bp = \frac{2\pi N\tau}{60}$$

**where:**

**T** is the torque, in Newton meter (N.m),

**N** is the rotational speed, in minutes,

**bp** is the brake power, in watt.

However while calculating the **Mechanical efficiency** another factor called **Indicated Power (ip)** is considered. It is defined as the power developed by combustion of fuel in the engine cylinder. It is always more than brake power and is given by,

$$ip = \frac{PVNK}{60}$$

where:

**P** is the mean pressure,

**V** is the displacement volume of the piston

**N** is the rotational speed, in minutes

**K** is the number of cylinders

Therefore, the difference between  $ip$  and  $bp$  indicates the power loss in the mechanical components of engine (due to friction).

So the mechanical efficiency is defined as ratio of brake power to the indicated power.

$$E = \frac{bp}{ip} \text{ or } E = \frac{bp}{bp + fp}$$

### **Measurement of brake power**

- The torque and the angular speed measurement of engine are involved in measurement of brake power.
- Dynamometer is used for torque measurement. The rotor of the engine which is under state is connected to stator. Rotor moves through distance  $2\pi r$  against force  $F$ . Hence work done,

$$W = 2\pi r F$$

They are of two types-

1. Absorption dynamometer
2. Transmission dynamometer

## **1. Absorption dynamometer**

- It absorbs and measures output power of engine. This power is dissipated in the form of heat. e.g., prony brake, hydraulic dynamometer, rope dynamometer, eddy current dynamometer, swinging field d.c. dynamometer etc.
- Absorption dynamometers are ideally suited for testing petrol engines for mopeds and electrical F.H.P. motors. Their main advantage lies in the fact that they are self-air-cooled and hence water cooling or additional air cooling is not required.

## **2. Transmission dynamometer**

- In this the power is transmitted to load connected to engine. Torque meter is alternative name of this dynamometer.
- It usually consist of strain gauge which measures the torque by angular deformation of shaft.
- These dynamometers are accurate and widely used in automatic units.

## **Air–fuel ratio**

- It is the ratio of mass of fuel to mass or volume of air in mixture. It affects the phenomenon of combustion and used for determining flame propagation velocity, the heat released in combustion chamber. For practice always relative air fuel ratio is defined. It is the ratio of actual air–fuel ratio to that of the stoichiometric air fuel ratio required for burning of fuel which is supplied.
- Relative ratio,

$$\lambda : (A/F) = \{ \text{Actual air-fuel ratio} / \text{Stoichiometric air-fuel ratio} \}$$

## **Volumetric efficiency**

- It is the ratio of the actual volume of the charge drawn in during the suction stroke to the swept volume of the piston.
- The amount of air taken inside the cylinder is dependent on the volumetric efficiency of an engine and hence puts a limit on the

amount of fuel which can be efficiently burned and the power output.

- The value of volumetric efficiency of a normal engine lies between 70 and 80 percent, but for engines with forced induction it may be more than 100 percent.

### **Specific output and specific weight**

- Specific output of an engine is defined as the brake power (output) per unit of piston displacement and is given by,

$$\text{Specific output} = \frac{bp}{A \times L}$$

- Specific weight is defined as the weight of the engine in kilogram for each brake power developed and is an indication of the engine bulk. Specific weight plays an important role in applications such as power plants for aircrafts.

### **Thermal efficiency and heat balance**

- Thermal efficiency of an engine is defined as the ratio of the output to that of the chemical energy input in the form of fuel supply.
- It may be based on brake or indicated output. It is the true indication of the efficiency with which the chemical energy of fuel (input) is converted into mechanical work.
- Thermal efficiency also accounts for combustion efficiency, i.e., for the fact that whole of the chemical energy of the fuel is not converted into heat energy during combustion.

$$\text{Brake thermal efficiency} = \frac{bp}{m_f \times C_v}$$

Where,

$C_v$  = Calorific value of fuel, kJ/kg, and  
 $m_f$  = Mass of fuel supplied, kg/sec.

- The energy input to the engine goes out in various forms – a part is in the form of brake output, a part into exhaust, and the rest is taken by cooling water and the lubricating oil.
- The break-up of the total energy input into these different parts is called the heat balance.
- The main components in a heat balance are brake output, coolant losses, heat going to exhaust, radiation and other losses.
- Preparation of heat balance sheet gives us an idea about the amount of energy wasted in various parts and allows us to think of methods to reduce the losses so incurred.

### **Brake specific fuel consumption (BSFC)**

- It is defined as the amount of fuel consumed for each unit of brake power per hour; it indicates the efficiency with which the engine develops the power from fuel. It is used to compare performance of different engines.
- The amount of fuel which an engine consumes is rated by its brake specific fuel consumption (BSFC).
- For most internal combustion engines the BSFC will be in the range of 0.5 to 0.6.
- The fuel efficiency will tend to peak at higher engine speeds. The BSFC tends to be the same for similar engines.
- The estimate of brake specific fuel consumption for two-stroke engines ranges from 0.55 to as high as 0.8 pounds of fuel per horsepower per hour.

### **Exhaust smoke and other emission**

- Smoke and other emission are undesirable for public environment.
- Because of global warming and emphasis on air pollution all possible things are tried to keep them low.
- Smoke is an indication of incomplete combustion. It limits the output of an engine if air pollution control is the consideration.
- Here are some tips of what you can adopt as air pollution solutions:
- Air conditioning systems and electrical gadgets within the vehicle (e.g. sound system, mobile tv systems) also take up energy. So if they are not in use, turn them off.
- Keep your car in efficient working condition.
- check the pressure of your car tires regularly.
- Get rid of excess load in your car.

### **Mean effective pressure and torque**

Mean effective pressure is an important parameter for comparing the performance of different engines. It is defined as the average pressure acting over piston throughout a power stroke. It is given by the following relation;

$$p = \frac{ip60}{LARK}$$

where: P is the Mean Effective Pressure,  
 ip is Indicated Power  
 A is the Area of the Piston  
 R is the Rotational Speed  
 K is the Number of Cylinders,  
 L is stroke length



- If mean effective pressure is based on brake power(bp) then it is referred to as brake mean effective pressure(bmep). If it is based on indicated power(ip) it is called indicated mean effective pressure(imep).
- Mean effective pressure also has an effect on torque. Torque could be expressed by following relation also,

$$\tau = \frac{bmepARK}{2\pi}$$

- Mean effective pressure and torque both are affected by the size of engine. A large engine produces more Torque for the same mean effective pressure. For this reason engines mean effective pressure gives indication of its displacement utilization and not torque.
- Power of an engine is dependent on its size so it is not possible to compare different engines based on their power or torque. Therefore, mean effective pressure is the true indication of the relative performance of different engines.

## CHAPTER-2

# AIR COMPRESSOR

### Introduction

Compressors are work absorbing devices which are used for increasing pressure of fluid at the expense of work done on fluid. The compressors used for compressing air are called air compressors. Some of popular applications of compressor are, for driving pneumatic tools and air operated equipments, spray painting, compressed air engine, supercharging in internal combustion engines, material handling (for transfer of material), surface cleaning, refrigeration and air conditioning, chemical industry etc.

### Classification of Compressors

**(a) Based on principle of operation:** Based on the principle of operation compressors can be classified as,

- (i) Positive displacement compressors
- (ii) Non-positive displacement compressors

**In positive displacement compressors the compression is realized by displacement of solid boundary and preventing fluid by solid boundary from flowing back in the direction of pressure gradient.** Positive displacement compressors can be further classified based on the type of mechanism used for compression.

- (i) Reciprocating type positive displacement compressors
- (ii) Rotary type positive displacement compressors

Reciprocating compressors generally, employ piston-cylinder arrangement where displacement of piston in cylinder causes rise in pressure. **Reciprocating compressors are capable of giving large pressure ratios but the mass handling capacity is limited or small.** Reciprocating compressors may also be single acting compressor (one delivery stroke per revolution) or double acting (two delivery strokes per revolution of crank) compressor.

Rotary compressors employing positive displacement have a rotary part whose boundary causes positive displacement of fluid and thereby compression. Rotary compressors of this type are available in the names as given below;

- (i) Roots blower
- (ii) Vaned type compressors
- (iii) Screw compressor
- (iv) Scroll compressor

Non-positive displacement compressors, also called as steady flow compressors use dynamic action of solid boundary for realizing pressure rise. Non-positive displacement compressor can be classified depending upon type of flow in compressor

- (i) axial flow type
- (ii) centrifugal type

**(b) Based on number of stages:** Compressors can be single stage or multistage.

- (i) Single stage compressor, for delivery pressure up to 5 bar
- (ii) Two stage compressor, for delivery pressure between 5 and 35 bar
- (iii) Three stage compressor, for delivery pressure between 35 and 85 bar
- (iv) Four stage compressor, for delivery pressure more than 85 bar

**(c) Based on capacity (air delivered per unit time) of compressors:**

- (i) Low capacity compressors, having air delivery capacity of 0.15 m<sup>3</sup>/s or less
- (ii) Medium capacity compressors, having air delivery capacity between 0.15 and 5 m<sup>3</sup>/s.
- (iii) High capacity compressors, having air delivery capacity more than 5 m<sup>3</sup>/s.

**(d) Based on highest pressure developed:** Typical values of maximum pressure developed for different compressors are as under;

- (i) Low pressure compressor, having maximum pressure up to 1 bar
- (ii) Medium pressure compressor, having maximum pressure from 1 to 8 bar
- (iii) High pressure compressor, having maximum pressure from 8 to 10 bar
- (iv) Super high pressure compressor, having maximum pressure more than 10 bar.

### RECIPROCATING COMPRESSORS

Reciprocating compressor has piston cylinder arrangement as shown in Fig. (1)

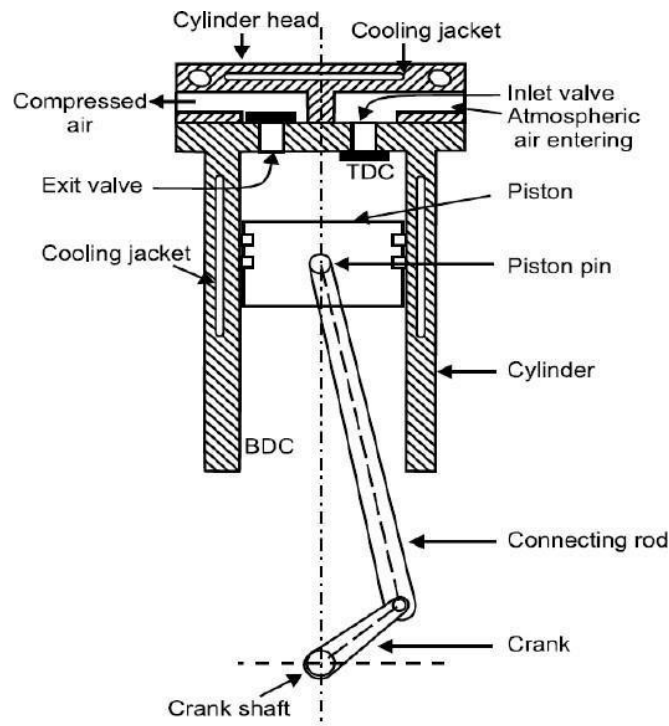

Fig. (1) Line diagram of reciprocating compressor

**Construction:** Reciprocating compressor has piston, cylinder, inlet valve, exit valve, connecting rod, crank, piston pin, crank pin and crank shaft. Inlet valve and exit valves may be of spring loaded type which get opened and closed due to pressure differential across them.

**Working:** Let us consider piston to be at top dead centre (TDC) and move towards bottom dead centre (BDC). Due to this piston movement from TDC to BDC suction pressure is created causing opening of inlet valve. With this opening of inlet valve and suction pressure, atmospheric air enters the cylinder. Air gets into cylinder during this stroke and is subsequently compressed in next stroke with both inlet valve and exit valve closed. After piston reaching BDC it reverses its motion and compresses the air inducted in previous

stroke. Compression is continued till the pressure of air inside becomes sufficient to cause deflection in exit valve. At the moment when exit valve plate gets lifted the exhaust of compressed air takes place. This piston again reaches TDC from where downward piston movement is again accompanied by suction. This is how reciprocating compressor keeps on working as flow device.

See the working of reciprocating compressor → <https://www.youtube.com/watch?v=F5Tcv8VxuG4>  
 → <https://www.youtube.com/watch?v=bJluUxA7aaY>

### Thermodynamic Analysis of Reciprocating Compressor

Compression of air in compressor may be carried out in three different ways of thermodynamic processes such as isothermal compression, polytropic compression or adiabatic compression. Figure (2) shows the thermodynamic cycle involved in compression. Clearance volume is provided in reciprocating compressor. Purpose of clearance volume in cylinder is twofold. One is to accommodate valve mechanism and another one is to prevent collision of piston with cylinder head.

On  $p$ - $V$  diagram process 4-1 shows the suction process followed by compression during 1-2, discharge process 2-3 and expansion of clearance air 3-4 (if clearance volume is provided).

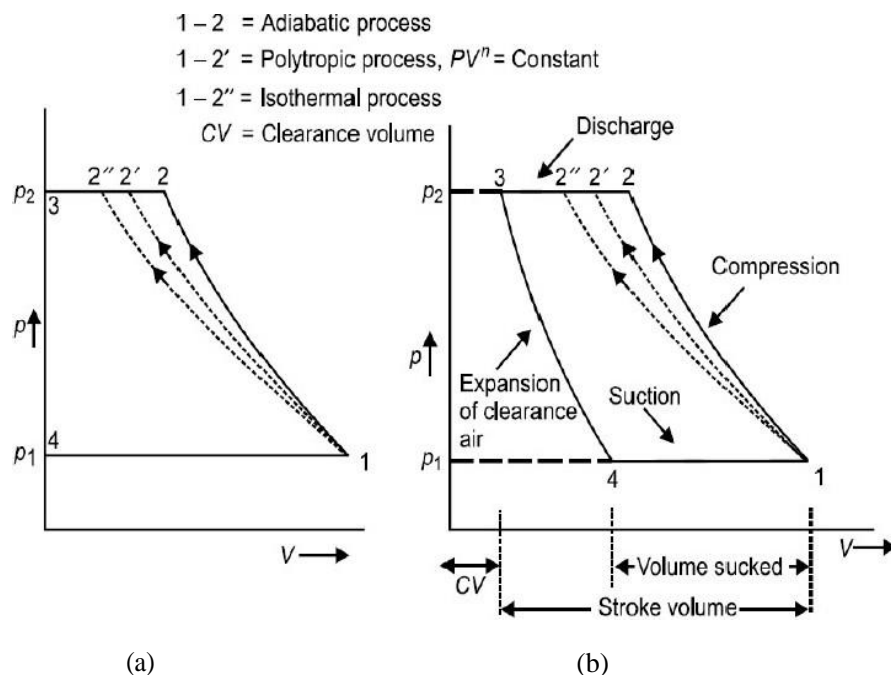

Fig. (2) Compression cycle on  $p$ - $V$  diagram (a) without clearance volume (b) with clearance volume

Air enters compressor at pressure  $p_1$  and is compressed up to  $p_2$ . Compression work requirement can be estimated from the area bounded by the curves comprising the cycle. Area on  $p$ - $V$  diagram shows that work requirement shall be minimum with isothermal process 1 - 2''. Work requirement is maximum with process 1-2 i.e. adiabatic process. As an engineer one shall attempt to minimise the requirement of compression-work. Therefore, ideally compression should occur isothermally for minimum work input. In practice, it is not possible to realise isothermal compression. Reason is maintaining constant temperature during compression is very difficult. Generally, compressors run at substantially high speed while isothermal compression requires compressor to run at very slow speed so that heat produced during compression is dissipated out and temperature remains constant. High running speed of compressor lead

compression process near to adiabatic or polytropic process. It is thus obvious that actual compression process should be compared with isothermal compression process. A mathematical parameter called isothermal efficiency is defined for quantifying the degree of deviation of actual compression process (adiabatic or polytropic process) from ideal compression process (isothermal compression process). Isothermal efficiency is defined as the ratio of isothermal work to actual indicated work in reciprocating compressor.

$$\text{Isothermal Efficiency} = \frac{\text{Isothermal Work}}{\text{Actual Indicated Work}}$$

Compression process following three different processes is also shown on  $T$ - $s$  diagram in Fig. (3).

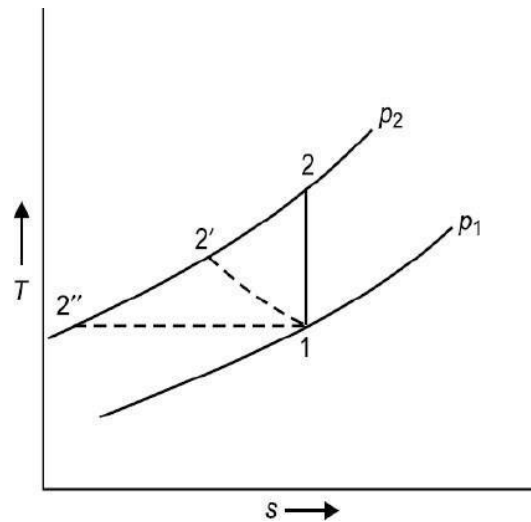

Fig. (3) Compression process on  $T$ - $S$  diagram.

**Compression Work,  $W_c$  (without clearance volume)**- Assuming compression process follow polytropic process i.e.  $pV^n = C$

$$\begin{aligned} W_c &= \text{Area on } p\text{-}V \text{ diagram} \\ &= \left[ p_2 V_2 + \left( \frac{p_2 V_2 - p_1 V_1}{n-1} \right) \right] - p_1 V_1 \\ &= \left( \frac{n}{n-1} \right) [p_2 V_2 - p_1 V_1] \\ &= \left( \frac{n}{n-1} \right) (p_1 V_1) \left[ \frac{p_2 V_2}{p_1 V_1} - 1 \right] \\ W_c &= \left( \frac{n}{n-1} \right) (p_1 V_1) \left[ \left( \frac{p_2}{p_1} \right)^{\frac{(n-1)}{n}} - 1 \right] \\ W_c &= \left( \frac{n}{n-1} \right) (mRT_1) \left[ \left( \frac{p_2}{p_1} \right)^{\frac{(n-1)}{n}} - 1 \right] \end{aligned}$$