

C.V. RAMAN POLYTECHNIC, BHUBANESWAR

DEPARTMENT OF MECHANICAL ENGINEERING

Study Material Of

Theory of Machine

4th Semester, Mechanical



Dr. Brundaban Sahoo

Asst.Prof (MECH)

SIMPLE MECHANISM

Q.1) Explain the term kinematic link? Give the classification of kinematic links?

Ans) **Kinematic link**: Each part of a machine which moves relative to some other part is called a kinematic link.

Explanation:

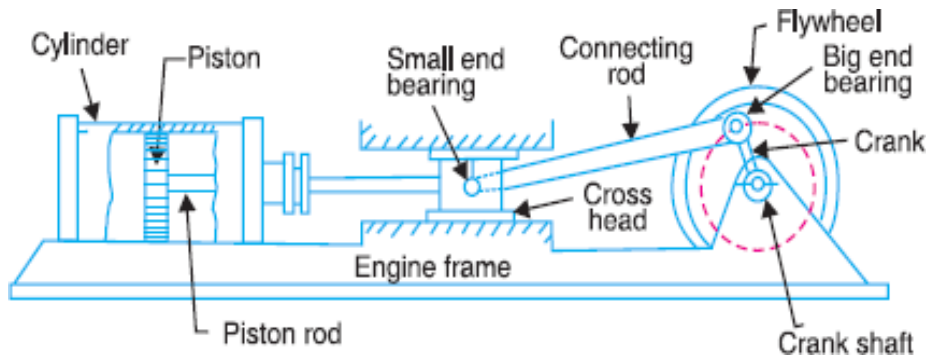

From the above Reciprocating steam engine (Slider crank mechanism) kinematic links are:

Link (1) - Frame & guides, Link (2) - Crank, Link (3) - Connecting rod, Link (4) – Slider.

Types of links:

- ♣ **Rigid Link**: It is one which does not undergo any deformation while transmitting motion.

Example: The deformation of a connecting rod and crank of a reciprocating steam engine is can be considered as rigid links.

- ♣ **Flexible Link**: It is one which is partly deformed in a manner not to affect the transmission of motion.

Example: Belts, ropes, chain drives & wires are flexible links.

- ♣ **Fluid Link**: It is one which is formed by having a fluid & the motion is transmitted through the fluid by pressure or compression only.

Example: Hydraulic presses, jacks and brakes.

Q.2) What is a kinematic pair? Explain different types of kinematic pairs?

Ans) **Kinematic pair**: The two links of a machine when in contact with each other are said to form a kinematic pair.

Classification of kinematic pairs:

(a) *According to nature of relative motion*:

- **Sliding Pair**: If one link of a pair has a sliding motion relative to other, then the pair is called as sliding pair.
Example: Rectangular rod in a rectangular hole.
- **Turning Pair / Revolving Pair**: If one link of a pair has a revolving motion relative to the other, then the pair is called as turning pair.
Example: Circular shaft revolving in a bearing.
- **Rolling Pair**: If one link of a pair has a rolling motion relative to the other, then the pair is called as rolling pair.
Example: Ball & roller bearings, and a rolling wheel on a flat surface.

- **Screw Pair / Helical Pair:** If two mating links of a pair have a turning as well as sliding motion between them, then the pair is called as screw pair.

Example: Lead Screw & the Nut of a Lathe.

- **Spherical Pair:** When one link in the form of a sphere turns inside a fixed link, then the obtained pair is called as spherical pair.

Example: Ball & Socket Joint.

(b) According to nature of contact:

- **Lower Pair:** A pair of links having surface or area contacts between the members is called as lower pair.

Example: All pairs of Slider crank mechanism, nut turning on a screw, and shaft rotating in bearing.

- **Higher Pair:** A pair of links having a point or line contact between the members is called as higher pair.

Example: Wheel rolling on a surface, cam & follower, and tooth gears.

(c) According to the nature of mechanical constraint or type of closure:

- **Closed pair / Self closed pair:** When the elements of a pair are held together mechanically, then the pair is called as closed pair

Example: All Lower pairs & some higher pairs.

- **Unclosed / forced closed pairs:** When two links of a pair are in contact either due to force of gravity or some spring action, then the pair is called as unclosed pair.

Example: Cam & Follower pairs.

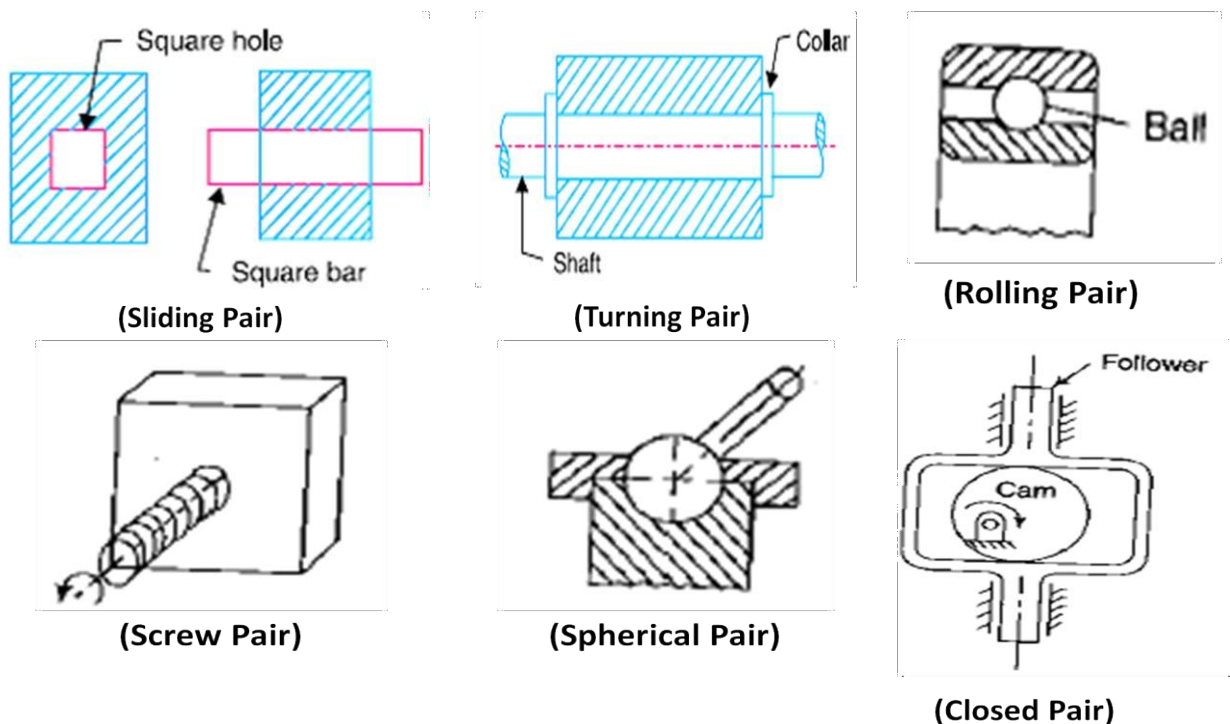

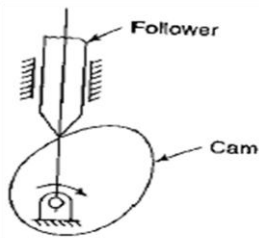

(Unclosed Pair)

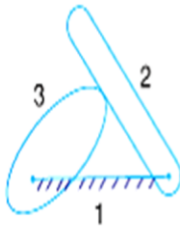

(Higher Pair)

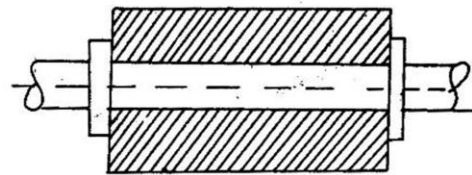
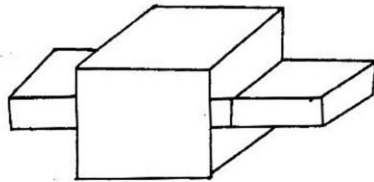
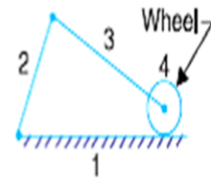

(Lower Pair)

Q.3) Define Kinematic chain. Give the classification of joints in a chain?

Ans) **Kinematic Chain**: When the kinematic pairs are coupled in such a way that last link is joined to the first link to transmit definite motion, it is called as kinematic chain.

Number of joints in a chain: $J = (3/2) L - 2$

Types of joints:

- **Binary Joint**: If two links are joined at the same connection, it is called a binary joint.
Example: A joint with two binary joints named B as shown in the below figure.
- **Ternary Joint**: If three links are joined at a connection, it is known as a ternary joint.
Example: Ternary links are named T as shown in the below figure.
- **Quaternary Joint**: If four links are joined at a connection, it is known as quaternary joint.
Example: Quaternary links are named Q as shown in the below figure.

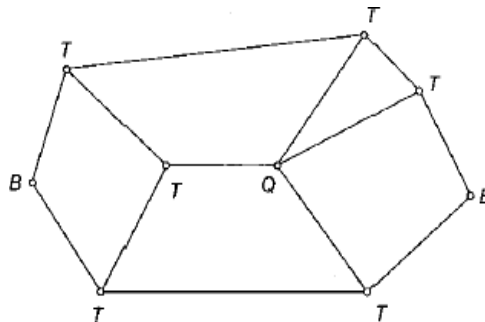

Q.4) Define Inversion of mechanism?

Ans) Inversion is the method of obtaining different mechanisms by fixing different links in a kinematic chain.

Q.5) What are the types of Kinematic Chains?

Ans) Types of kinematic Chains are (i) Four Bar Chain / Quadric Cycle Chain, (ii) Single Slider Crank Chain, (iii) Double Slider Crank Chain.

Q.6) Distinguish between ‘Machine’ and ‘Mechanism’.

Ans) **Machine:**

- It is a mechanism which receives energy and transforms it into some useful work.
- A machine transmits power & performs some particular type of work.
- All machines are mechanisms.

Mechanism:

- When one of the links of a kinematic chain is fixed, then it is known as mechanism. Thus mechanism is a constrained chain.
- A mechanism transmits & modifies a motion.
- All mechanisms are not machines.

Q.7) Distinguish between Structure and Machine

Ans) **Machine:**

- It is a mechanism or a combination of mechanisms.
- The parts of a machine move relative to one another.
- A machine transforms the available energy into some useful work.
- The links of a machine may transmit both power and motion.

Structure:

- It is an assembly of a number of resistant bodies having no relative motion between them.
- The members of a structure do not move relative to one another.
- A structure does not move relative to one another.
- The members of a structure transmit forces only.

Q.8) Describe the four bar chain mechanism and its inversions.

Ans) **Four Bar Chain / Quadric Cycle Chain:**

- It consists of four rigid links which are connected in the form of a quadrilateral by four pin-joints.
- A link makes complete revolution is called Crank (4).
- The link which is fixed is called fixed link (1).
- The link opposite to the fixed link is called Coupler (3).
- The fourth link is called Lever or Rocker (2).
- It is impossible to have a four bar linkage, if the length of one of the links is greater than the sum of the other three.
- Grashof's Law: For a four bar mechanism, the sum of the shortest and longest link lengths should not be greater than the sum of the remaining two link lengths.

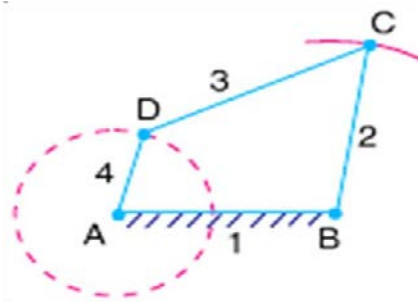

(Four bar chain)

Inversions of Four Bar Chain:

(i) First Inversion (Crank & Lever Mechanism):

If any of the adjacent links of link 'd', either link 'a' or 'c' is fixed, then the link 'd' (crank) can have full revolution and the link 'b' opposite to it oscillates. Such type of mechanism is called as crank-lever mechanism.

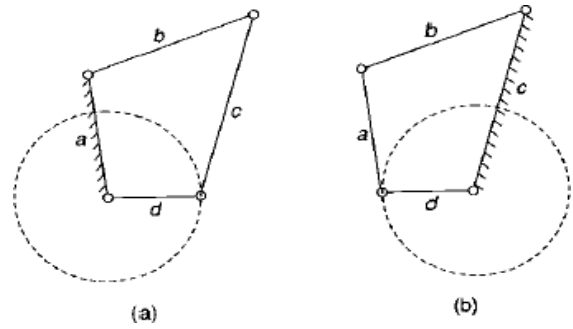

Example:- Beam Engine

In this mechanism the crank rotates about the fixed centre A and the lever oscillates about a fixed centre D.

The purpose of this mechanism is to convert rotary motion into reciprocating motion.

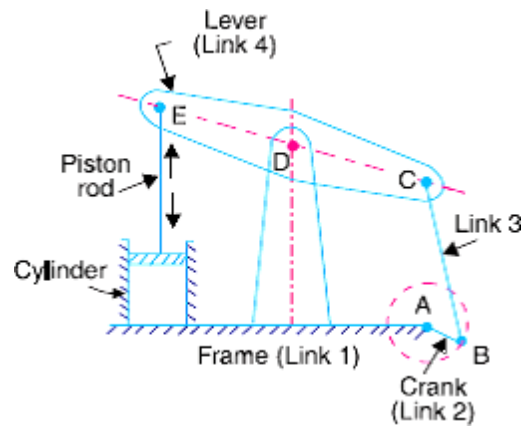

(ii) Second Inversion (Double Crank mechanism):

If the shortest link 'd' is fixed then the links 'a' and 'c' rotate full circle and link 'b' also complete one revolution relative to fixed link 'd'.

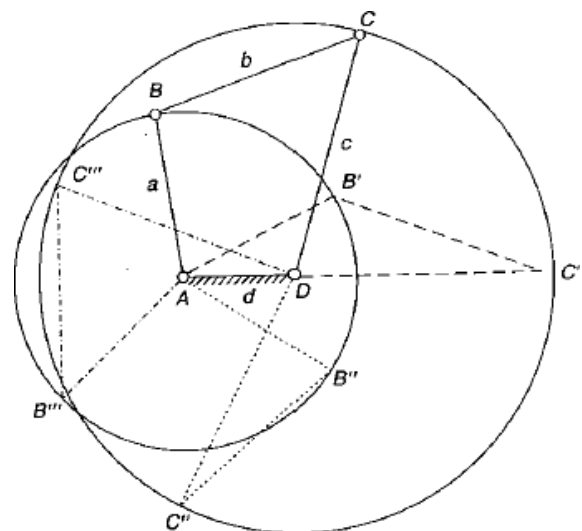

Example: Coupling Rod of a Locomotive (Double Crank Mechanism):

In this mechanism the two links 2 and 4 respectively are transmitting rotary motion between them. They are rotating with respect to link 1.

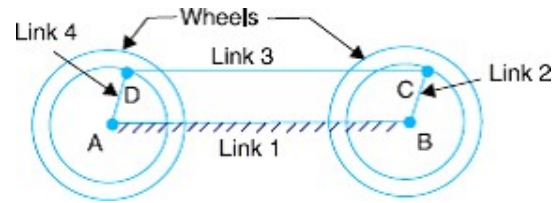

(iii) Third Inversion (Double Lever mechanism):

If the link opposite to the shortest link. i.e., link 'b' is fixed and the two links 'a' and 'c' would oscillate.

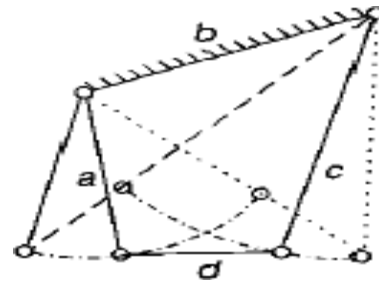

Example: Watt's indicator (Double Lever Mechanism):

It consists of four links which are:

Fixed link at A, link AC, link CE and link BFD.

The links CE and BFD act as lever.

It is also called Watt's straight line mechanism and the dotted line shows the position of the mechanism.

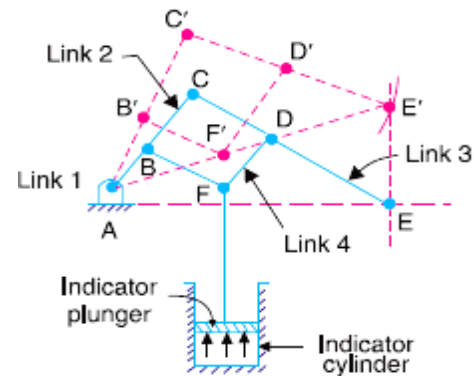

Q.9) Sketch and describe the various inversions of a Slider Crank Chain?

Ans) Slider Crank Chain:

- When one of the turning pairs of a four bar chain is replaced by a sliding pair, it becomes a single slider crank chain.
- It consists of one sliding pair and three turning pairs.
- In a single slider crank chain as shown in the above figure, the links 1&2, links 2&3, and links 3&4 form three turning pairs while the links 4&1 form a slider pair.

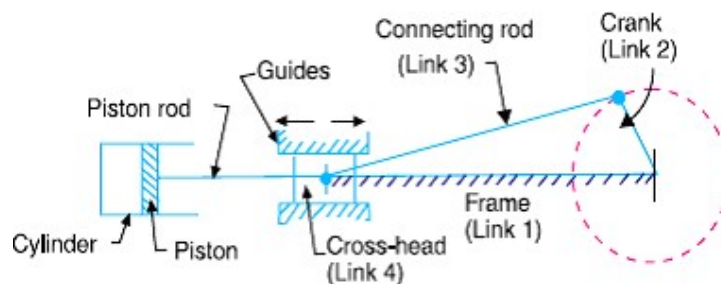

Inversions of Single Slider Crank Chain:

(i) First Inversion:

This inversion is obtained when **link 1** is fixed and links 2 & 4 are made the crank & the slider respectively.

Example:

- Reciprocating Steam Engine: Link 4 (piston) is the driver.
- Reciprocating Compressor. Link 2 (crank) is the driver.

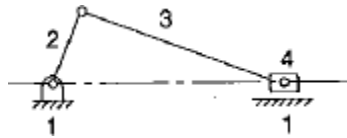

(ii) Second Inversion:

This inversion is obtained when link 2 is fixed; link 3 along with the slider becomes crank and link 1 rotate about O along with the slider which also reciprocates on it.

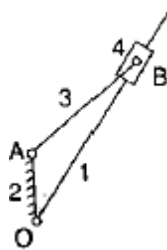

Example:

(a) Whitworth quick-return mechanism:

- This mechanism used in shaping and slotting machines.
- In this mechanism the link CD (link 2) forming the turning pair is fixed; the driving crank CA (link 3) rotates at a uniform angular speed and the slider (link 4) attached to the crank pin at A slides along the slotted bar PA (link 1) which oscillates at D.
- The connecting rod PR carries the ram at R to which a cutting tool is fixed and the motion of the tool is constrained along the line RD produced.
- The length of effective stroke = 2 PD. And mark $P_1R_1 = P_2R_2 = PR$.

$$\frac{\text{Time of cutting stroke}}{\text{Time of return stroke}} = \frac{\alpha}{\beta} = \frac{\alpha}{360^\circ - \alpha} \quad \text{or} \quad \frac{360^\circ - \beta}{\beta}$$

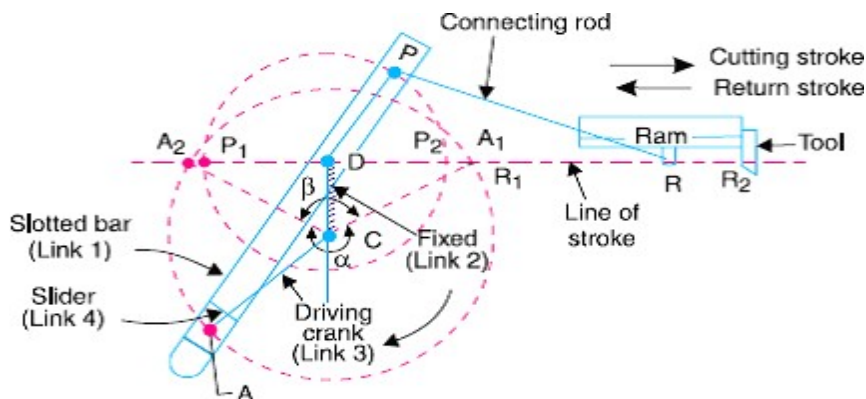

(b) Rotary internal combustion engine:

- This mechanism is used in aviation.
- It consists of seven cylinders in one plane and all revolves about fixed centre D.
- The crank 2 is fixed, connecting rod 4 rotates and the piston 3 reciprocates inside the cylinders forming link 1.

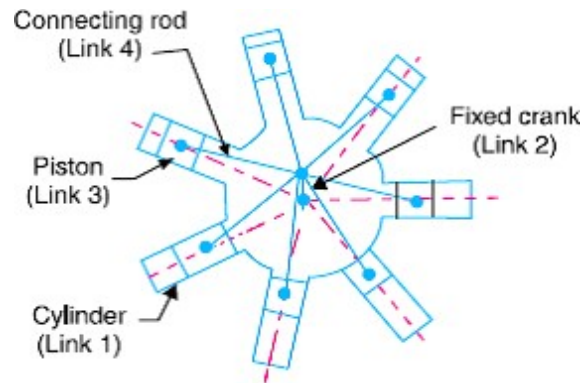

(iii) Third Inversion:

This inversion is obtained when the link 3 is fixed, the link 2 acts as a crank and link 4 oscillates.

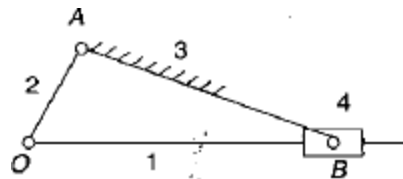

Example:

(a) Oscillating cylinder engine:

- It is used to convert reciprocating motion into rotary motion.
- In this mechanism link 3 is fixed, the crank 2 rotates, piston rod 1 reciprocates and cylinder 4 oscillates about A.

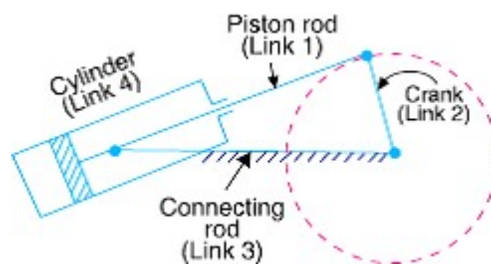

(b) Crank & slotted lever mechanism:

- This mechanism is used in shaping machines, slotting machines and in rotary internal combustion engine.
- In this mechanism link AC(3) corresponding to the connecting rod is fixed, the driving crank CB revolves about the fixed centre C and a sliding block attached to the crank pin at B slides along the slotted bar AP.

- AP oscillates about A and a short link PR transmits motion from AP to the arm which reciprocates along the line of stroke R_1R_2 .

$$\frac{\text{Time of cutting stroke}}{\text{Time of return stroke}} = \frac{\beta}{\alpha} = \frac{\beta}{360^\circ - \beta} \quad \text{or} \quad \frac{360^\circ - \alpha}{\alpha}$$

$$\text{Length of stroke} = R_1R_2 = P_1P_2 = 2P_1Q = 2AP \cos \frac{\alpha}{2} = 2AP \times \frac{CB_1}{AC} = 2AP \times \frac{CB}{AC}$$

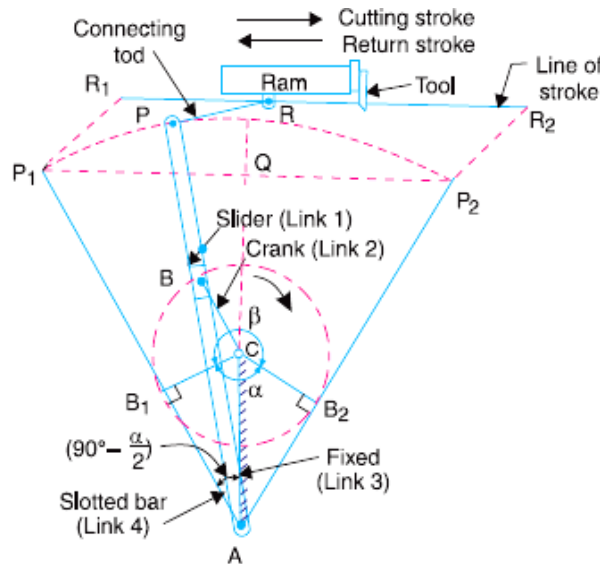

(iv) Fourth Inversion:

This inversion is obtained when the link 4 is fixed, the link 3 oscillates about B on the link 4 and the end A of the link 2 is oscillates about B and the end O reciprocates along the fixed link-4.

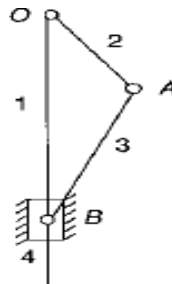

Example:

(a) Hand Pump:

The link 4 is made in the form of a cylinder and a plunger fixed to the link 1 reciprocates in it.

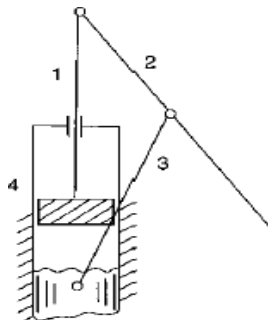

Q.10) Write a short note on Cam and Follower.

Ans) **Cam & Follower:**

- A cam may be defined as a rotating, reciprocating or oscillating machine part, designed to produce reciprocating and oscillating motion of another mechanical part, called a follower.
- A follower is a reciprocating or oscillating member which follows motion of cam.
- A cam and follower have a line contact between them and as such they constitute a higher pair. The contact between them is maintained by an external force which may provide by a spring or sometimes by the sufficient weight of the follower itself.
- Cams are classified according to its Shape, Follower movement and Type of constraints.
- Followers may be classified according to the type of motion, the axis of the motion and the shape of their contacting end with the cam.
- Various types of cams are flat cams, disc cams, spiral cams, cylindrical cams and spherical cams etc.
- Various types of follower are knife-edge, roller, reciprocating, oscillating, radial follower etc.
- Applications:

The cams are widely used for inlet and exhaust valve of internal combustion engine, automatic attachment of machineries, paper cutting machines, feed mechanism of automatic lathe etc.

END of Chapter

FRICITION

Q.1) Define the terms (i) coefficient of friction, (ii) angle of friction, (iii) angle of repose and (iv) limiting friction.

Ans) (i) Coefficient of friction:

It is defined as the ratio of the limiting friction (F) to the normal reaction (R_N) between the two bodies. It is denoted by ' μ '. $\mu = F / R_N$

(ii) Limiting angle of friction:

It is the angle between the resultant limiting friction and the normal reaction.

It is the angle made by the resultant of force of friction and normal reaction with normal reaction. It is denoted by ' ϕ '.

We may write, $\tan \phi = \mu = F / R_N$ OR $\phi = \tan^{-1}(\mu)$

(iii) Angle of Repose:

It is the angle made by the inclined plane with the horizontal plane when a body starts moving without the application of force. The body tends to slide when the angle of inclination of the plane is equal to the angle of friction. i.e. $\mu = \phi$.

(iv) Limiting friction:

It is the maximum value of frictional force experienced by the body, when the body just begins to slide over the surface of another body.

Q.2) Draw the neat sketch of screw jack.

Ans)

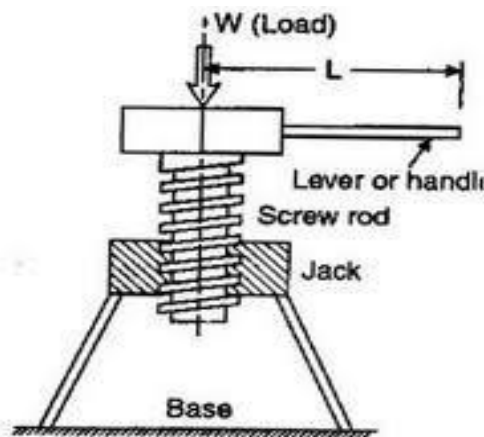

Q.3) Define pitch and lead. State the relation between them.

Ans) Pitch (p): It is the linear distance taken from one point of thread to corresponding point of next thread.

Lead (L): It is the axial distance covered by a screw in one rotation.

Relation between lead and pitch:

Lead = $n \times$ pitch where, n = number of threads per pitch length

Q.4) Derive an expression for torque required to raise and lower the load by Screw jack. Determine its efficiency.

Ans) Torque required lowering the load by Screw jack:

Let, W = weight to be lifted
 ϕ = limiting angle of friction

α = helix angle R_N = normal reaction
 P = effort required to lower the load

Resolving all the forces perpendicular the plane,

$$R_N = W \cos \alpha + P \sin \alpha \text{----- (i)}$$

Resolving the forces parallel to the plane,

$$P \cos \alpha = W \sin \alpha - \mu R_N \text{---- (ii)}$$

Putting the value of R_N in equation-(ii), we

$$\begin{aligned} P \cos \alpha &= W \sin \alpha - \mu (W \cos \alpha + P \sin \alpha) \\ &= W \sin \alpha - \mu W \cos \alpha - \mu P \sin \alpha \end{aligned}$$

$$\Rightarrow P \cos \alpha + \mu P \sin \alpha = W \sin \alpha - \mu W \cos \alpha$$

$$\Rightarrow P (\cos \alpha + \mu \sin \alpha) = W (\sin \alpha - \mu \cos \alpha)$$

$$\Rightarrow \boxed{P = W \times \frac{\sin \alpha - \mu \cos \alpha}{\cos \alpha + \mu \sin \alpha}} \text{----- (iii)}$$

Replacing the value, $\mu = \frac{\sin \phi}{\cos \phi}$

$$\Rightarrow P = W \times \frac{\sin \alpha - \frac{\sin \phi}{\cos \phi} \cdot \cos \alpha}{\cos \alpha + \frac{\sin \phi}{\cos \phi} \cdot \sin \alpha}$$

$$\text{Torque required to lower the load (T)} = P \times \frac{d}{2}$$

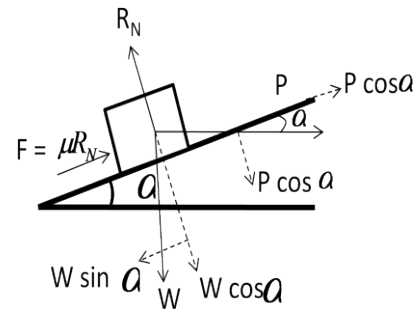

$$\Rightarrow P = W \times \left(\frac{\sin \alpha \cos \phi - \sin \phi \cos \alpha}{\cos \alpha \cos \phi + \sin \alpha \sin \phi} \right)$$

$$\Rightarrow P = \frac{W \sin (\alpha - \phi)}{\cos (\alpha - \phi)}$$

$$\Rightarrow \boxed{P = W \tan (\alpha - \phi)} \text{..... (iv)}$$

Torque required rising the load by Screw jack:

Let, W = weight to be lifted α = angle of inclination R_N = normal reaction
 ϕ = limiting angle of friction, P = effort required to raise the load

Resolving all the forces perpendicular the plane,

$$R_N = W \cos \alpha + P \sin \alpha \text{----- (i)}$$

Resolving the forces parallel to the plane,

$$P \cos \alpha = W \sin \alpha + \mu R_N \text{----- (ii)}$$

Putting the value of R_N in equation-(ii), we

$$\text{get: } P \cos \alpha = W \sin \alpha + \mu (W \cos \alpha + P \sin \alpha)$$

$$\Rightarrow P \cos \alpha - \mu P \sin \alpha = W \sin \alpha + \mu W \cos \alpha$$

$$\Rightarrow P (\cos \alpha - \mu \sin \alpha) = W (\sin \alpha + \mu \cos \alpha)$$

$$\Rightarrow \boxed{P = W \times \frac{\sin \alpha + \mu \cos \alpha}{\cos \alpha - \mu \sin \alpha}} \text{----- (iii)}$$

Replacing the value, $\mu = \frac{\sin \phi}{\cos \phi}$ we get:

$$\Rightarrow P = W \times \frac{\sin \alpha + \frac{\sin \phi}{\cos \phi} \cdot \cos \alpha}{\cos \alpha - \frac{\sin \phi}{\cos \phi} \cdot \sin \alpha}$$

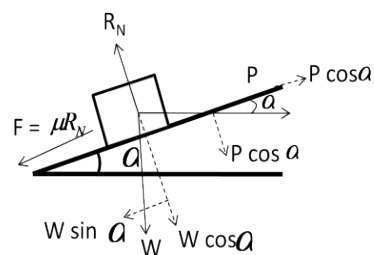

$$\Rightarrow P = W \times \left(\frac{\sin \alpha \cos \phi + \sin \phi \cos \alpha}{\cos \alpha \cos \phi - \sin \alpha \sin \phi} \right)$$

$$\Rightarrow P = \frac{W \sin (\alpha + \phi)}{\cos (\alpha + \phi)}$$

$$\Rightarrow \boxed{P = W \tan (\alpha + \phi)} \text{----- (iv)}$$

Torque required to raise the load (T) = $P \times \frac{d}{2}$

Mechanical efficiency of a square threaded screw jack:

The efficiency of the screw jack may be defined as the ratio of the ideal effort to the actual effort.

We know that actual effort (P) = $W \tan (\alpha + \phi)$

Where, α = helix angle,

ϕ = angle of friction,

μ = coefficient of friction

If there will no friction between screw and nut, then $\phi = 0$,

Thus ideal effort $P_o = W \tan \alpha$,

$$\text{Efficiency} = \frac{\text{Ideal effort}}{\text{Actual effort}} = \frac{P_o}{P} = \frac{W \tan \alpha}{W \tan (\alpha + \phi)} = \frac{\tan \alpha}{\tan (\alpha + \phi)}$$

Q.5) State the condition of reversibility and self-locking of a Screw jack.

Ans) Condition of self locking:

If the efficiency of the screw jack is greater than 50% then the machine is known as reversible.

For self locking of the screw, $\phi \geq \alpha$ or $\phi \leq \alpha$.

$$\text{Thus; Efficiency } (\eta) < \frac{\tan \alpha}{\tan (\alpha + \phi)} < \frac{\tan \alpha}{\tan 2\phi} < \frac{\tan \alpha \times (1 - \tan^2 \phi)}{2 \tan \phi} < \frac{1 - \tan^2 \phi}{2} < \frac{1}{2} - \frac{\tan^2 \phi}{2}$$

From this expression we conclude that, $\eta < (1/2)$ or 50%.

This is the condition of self locking.

Condition of reversibility or overhauling:

If the efficiency of the screw jack is less than or equal to 50% then the machine is known as self-locking.

For overhauling or reversibility of screw, $\phi \leq \alpha$ or $\phi \geq \alpha$.

$$\text{Thus; Efficiency } (\eta) \geq \frac{\tan \alpha}{\tan (\alpha + \phi)} < \frac{\tan \alpha}{\tan 2\phi} < \frac{\tan \alpha \times (1 - \tan^2 \phi)}{2 \tan \phi} < \frac{1 - \tan^2 \phi}{2} < \frac{1}{2} - \frac{\tan^2 \phi}{2}$$

From this expression we conclude that, $\eta > (1/2)$ or 50%.

This is the condition of reversibility.

Q.6) State the condition for maximum efficiency of a screw jack. State the formula to determine maximum efficiency.

Ans) The condition for maximum efficiency of the screw jack is: $\alpha = 45^\circ - \phi/2$

Where, α = helix angle and ϕ = friction angle

Maximum efficiency is given by $\eta_{\max} = \frac{1 - \sin \phi}{1 + \sin \phi}$

Q.11) Classify bearings and explain them.

Ans) Bearings are classified as sliding bearing and rolling bearing. Sliding bearing is including journal bearing and thrust bearing. Rolling bearing is including ball bearing, roller bearing and needle roller bearing.

Journal bearing:

Journal bearing is used to support the load in the direction of diameter.

Thrust bearing:

Thrust bearing is used to support the axle which carries the axial load.

Rolling bearing:

Rolling bearing can reduce the friction produced by the rotating shaft when it rotates.

Ball bearing:

Ball bearing uses balls as a medium between the fixed components and the rotating components, such as the moving parts at the bottom of a gate and reduces the friction.

Roller bearing:

Roller bearing works similarly as ball bearing but it uses cylinders instead of balls.

Needle roller bearing:

A needle roller bearing works similarly as ball bearing but it uses the typical structure consists of a needle cage which orients and contains the needle rollers. Needle bearings have a large surface area that is in contact with the bearing outer surfaces compared to ball bearings.

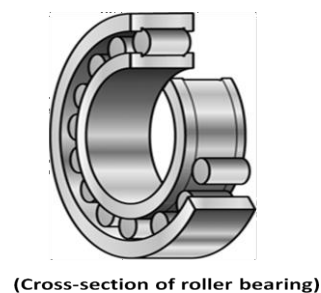
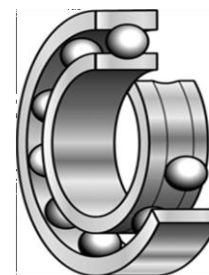
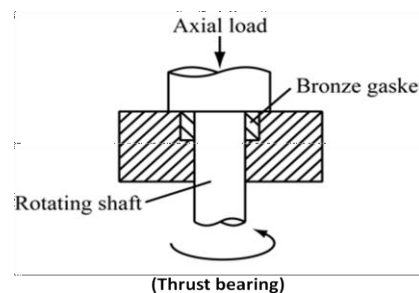
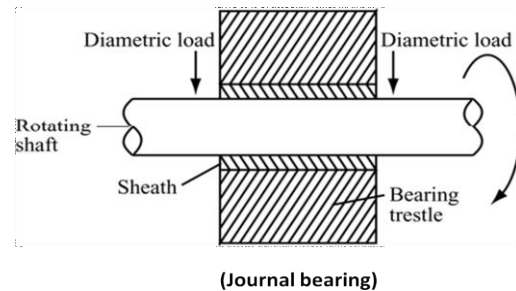

Q.12) What are the assumptions made in finding power lost in friction in bearing.

Ans) Assumptions are: (i) uniform pressure theory, (ii) uniform wear theory.

Q.13) Derive an expression for total frictional torque in a flat collar bearing / thrust bearing.

Ans) Total frictional torque in a flat collar bearing:

Consider a single flat collar bearing supporting a shaft as shown in figure.

Let, W = load transmitted over bearing surface.

p = intensity of pressure per unit area of bearing surface.

r_1 = external radius of collar.

r_2 = internal radius of collar.

μ = coefficient of friction.

Area of the bearing surface (A) = $\pi [r_1^2 - r_2^2]$

Consider a ring of radius ' r ' and thickness ' dr '.

Area of the ring = $2\pi r \times dr$

Load transmitted on the ring (dW) = $p \times 2\pi r \times dr$

Frictional resistance on the ring (dF) = $\mu \times dW = 2\pi \times \mu \times p \times r \times dr$

Frictional torque on ring (dT) = $dF \times r = 2\pi \times \mu \times p \times r^2 \times dr$

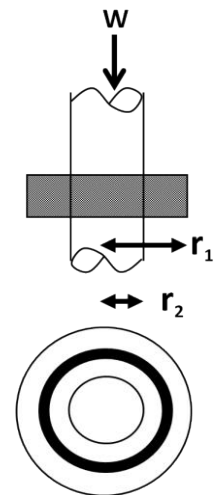

Considering uniform pressure condition:

$$\text{Intensity of pressure (p)} = \frac{W}{\pi [r_1^2 - r_2^2]} \quad \text{----- (1)}$$

We know that, Frictional torque on ring (dT) = $dF \times r = 2\pi \times \mu \times p \times r^2 \times dr$

By integrating the above equation from r_2 to r_1 we get;

$$\begin{aligned} \text{Total frictional torque on bearing surface (T)} &= \int_{r_2}^{r_1} (2\pi \times \mu \times p \times r^2 \times dr) \\ &= 2\pi \times \mu \times p \times \int_{r_2}^{r_1} (r^2 \times dr) \\ &= 2\pi \times \mu \times p \times \left[\frac{r^3}{3} \right]_{r_2}^{r_1} \\ &= 2\pi \times \mu \times p \times \left(\frac{r_1^3 - r_2^3}{3} \right) \end{aligned}$$

Replacing the value of ' p ' from equation-1, we get:

$$\begin{aligned} \text{Total frictional torque on bearing surface (T)} &= 2\pi \times \mu \times \frac{W}{\pi [r_1^2 - r_2^2]} \times \left(\frac{r_1^3 - r_2^3}{3} \right) \\ &= \frac{2}{3} \times \mu \times W \times \left(\frac{r_1^3 - r_2^3}{r_1^2 - r_2^2} \right) = \mu \times W \times R \end{aligned}$$

$$\text{Where, } R = \frac{1}{3} \times \frac{r_1^3 - r_2^3}{r_1^2 - r_2^2} = \text{mean radius}$$

Considering uniform wear condition:

The rate of wear depends upon the intensity of pressure and velocity of rubbing surface. It is proportional to $(p \times v)$, but velocity increases with distance or radius ' r '. So we can write:

$$p \cdot r = C \quad \text{or} \quad p = \frac{C}{r}$$

We know that, Load transmitted on ring = $p \times 2\pi r \times dr = \frac{C}{r} \times 2\pi r \times dr = 2\pi C \times dr$

Load transmitted to bearing (W) = $\int_{r_2}^{r_1} (2\pi \times C \times dr) = 2\pi C \times [r]_{r_2}^{r_1} = 2\pi C \times (r_1 - r_2)$

$$\text{Or} \quad C = \frac{W}{2\pi \times (r_1 - r_2)} \quad \text{----- (2)}$$

We know that, Frictional torque on ring (dT) = $dF \times r = 2\pi \times \mu \times p \times r^2 \times dr$
replacing the ' p ' value we get;

Frictional torque on ring (dT) = $dF \times r = 2\pi \times \mu \times C \times r \times dr$

By integrating the above equation from r_2 to r_1 we get;

$$\begin{aligned} \text{Total frictional torque on bearing surface (T)} &= \int_{r_2}^{r_1} (2\pi \times \mu \times C \times r \times dr) \\ &= 2\pi \times \mu \times C \times \int_{r_2}^{r_1} (r \times dr) \\ &= 2\pi \times \mu \times C \times \left[\frac{r^2}{2} \right]_{r_2}^{r_1} \\ &= 2\pi \times \mu \times C \times \left(\frac{r_1^2 - r_2^2}{2} \right) \\ &= \pi \times \mu \times C \times (r_1^2 - r_2^2) \end{aligned}$$

replacing the value of 'C' from equation-2, we get

$$\begin{aligned} \text{Total frictional torque on bearing surface (T)} &= \pi \times \mu \times \frac{W}{2\pi \times (r_1 - r_2)} \times (r_1^2 - r_2^2) \\ &= \frac{1}{2} \times \mu \times W \times (r_1 + r_2) = \mu \times W \times R \end{aligned}$$

where, $R = \frac{r_1 + r_2}{2} = \text{mean radius}$

Q.14) Derive an expression for total frictional torque in a flat pivot bearing.

Ans) Total frictional torque in a flat pivot bearing:

Consider a flat pivot bearing supporting a shaft as shown in figure.

- Let, W = load transmitted over bearing surface.
 p = intensity of pressure per unit area of bearing surface.
 R = radius of the shaft.
 μ = coefficient of friction.

$$\text{Area of the bearing surface (A)} = \pi R^2$$

Consider a ring of radius 'r' and thickness 'dr'.

$$\text{Area of the ring} = 2\pi r \times dr$$

$$\text{Load transmitted on the ring (dW)} = p \times 2\pi r \times dr$$

$$\text{Frictional resistance (dF)} = \mu \times dW = 2\pi \times \mu \times p \times r \times dr$$

$$\text{Frictional torque on ring (dT)} = dF \times r = 2\pi \times \mu \times p \times r^2 \times dr$$

Considering uniform pressure condition:

$$\text{Intensity of pressure (p)} = \frac{W}{\pi R^2} \quad \text{----- (1)}$$

$$\text{We know that, Frictional torque on ring (dT)} = dF \times r = 2\pi \times \mu \times p \times r^2 \times dr$$

By integrating the above equation from r_2 to r_1 we get;

$$\begin{aligned} \text{Total frictional torque on bearing surface (T)} &= \int_0^R (2\pi \times \mu \times p \times r^2 \times dr) \\ &= 2\pi \times \mu \times p \times \int_0^R (r^2 \times dr) \\ &= 2\pi \times \mu \times p \times \left(\frac{R^3}{3} \right) \end{aligned}$$

Replacing the value of 'p' from equation-1, we get:

$$\begin{aligned} \text{Total frictional torque on bearing surface (T)} &= 2\pi \times \mu \times \frac{W}{\pi R^2} \times \left(\frac{R^3}{3} \right) \\ &= \frac{2}{3} \times \mu \times W \times R \end{aligned}$$

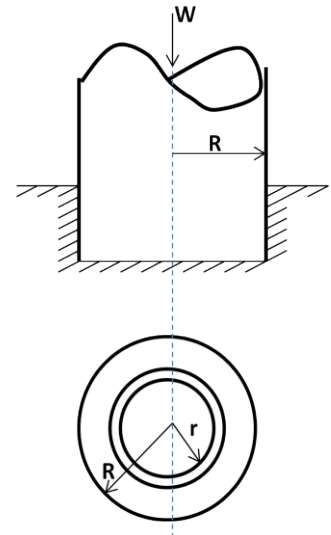

When the shaft rotates at w rad/s, power lost in friction (P) = $T.w$

$$\Rightarrow P = \frac{2\pi NT}{60} \quad \text{where, } w = \frac{2\pi N}{60} \quad \text{and} \quad N = \text{speed of the shaft in r.p.m.}$$

Considering uniform wear:

The rate of wear depends upon the intensity of pressure and velocity of rubbing surface. It is proportional to ($p \times v$), but velocity increases with distance or radius 'r'. So we can write:

$$p.r = C \quad \text{or} \quad p = \frac{C}{r}$$

We know that, Load transmitted on ring = $p \times 2\pi r \times dr = \frac{C}{r} \times 2\pi r \times dr = 2\pi C \times dr$

$$\text{Load transmitted to bearing (W)} = \int_0^R (2\pi \times C \times dr) = 2\pi C \times [r]_0^R = 2\pi C \times R$$

$$\text{Or} \quad C = \frac{W}{2\pi \times R} \quad \text{----- (2)}$$

We know that, Frictional torque on ring (dT) = $dF \times r = 2\pi \times \mu \times p \times r^2 \times dr$
replacing the 'p' value we get;

$$\text{Frictional torque on ring (dT)} = dF \times r = 2\pi \times \mu \times C \times r \times dr$$

By integrating the above equation from r_2 to r_1 we get;

$$\begin{aligned} \text{Total frictional torque on bearing surface (T)} &= \int_0^R (2\pi \times \mu \times C \times r \times dr) \\ &= 2\pi \times \mu \times C \times \int_0^R (r \times dr) \\ &= 2\pi \times \mu \times C \times \left[\frac{r^2}{2} \right]_0^R \\ &= 2\pi \times \mu \times C \times \left(\frac{R^2}{2} \right) \\ &= \pi \times \mu \times C \times R^2 \end{aligned}$$

replacing the value of 'C' from equation-2, we get

$$\text{Total frictional torque on bearing surface (T)} = \pi \times \mu \times \frac{W}{2\pi \times R} \times R^2 = \frac{1}{2} \times \mu \times W \times R$$

Q.15) A shaft has a number of collars integral with it. External diameter of collars is 400 mm and the shaft diameter is 250 mm. If the uniform intensity of pressure is $35 \times 10^4 \text{ N/m}^2$ and its coefficient of friction is 0.05, estimate (i) power absorbed in overcoming friction when the shaft runs at 105 rpm and carries a load of $15 \times 10^4 \text{ N}$ (ii) number of collars.

Ans) Data Given:

d_1 = external diameter of collar = 400 mm, d_2 = internal radius of collar = 250

mm uniform pressure (p) = $35 \times 10^4 \text{ N/m}^2$, coefficient of friction (μ) = 0.05

N = 105 r.p.m W = $15 \times 10^4 \text{ N}$

r_1 = 200 mm = 0.2 m, r_2 = 125 mm = 0.125 m

$$\text{Torque transmitted (T)} = \frac{2}{3} \mu W \left[\frac{r_1^3 - r_2^3}{r_1^2 - r_2^2} \right] = \frac{2}{3} \times 0.05 \times 15 \times 10^4 \times \left[\frac{0.2^3 - 0.125^3}{0.2^2 - 0.125^2} \right] = 1240.4 \text{ N-m}$$

$$\text{Power absorbed in overcoming friction} = P = \frac{2\pi NT}{60} = \frac{2\pi \times 105 \times 1240.4}{60} = 13.6 \times 10^3 \text{ Watt}$$

$$\begin{aligned} \text{Number of collars required (n)} &= \frac{\text{Total load}}{\text{load per collar}} = \frac{W}{p \times \pi \times (r_1^2 - r_2^2)} \\ &= \frac{15 \times 10^4}{35 \times 10^4 \times \pi \times (0.2^2 - 0.125^2)} = 5.6 \cong 6 \quad \text{(Ans)} \end{aligned}$$

Q.16) Derive an expression for total frictional torque in a conical pivot bearing.

Ans) Total frictional torque in a conical pivot bearing:

Consider a conical collar bearing as shown in figure.

Let, W = normal load transmitted over the bearing surface

P_n = intensity of pressure normal to the cone

α = semi angle of the cone

μ = coefficient of friction between shaft and bearing

r_1 = radius of the shaft

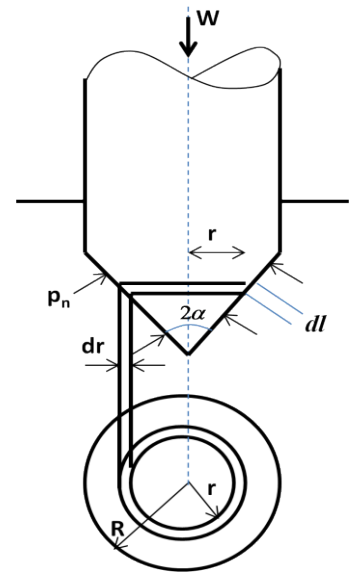

Consider a small ring of radius ' r ' and thickness ' dr '

Let, ' dl ' is the length of the ring along the cone = $dr \cdot \text{cosec } \alpha$

Area of the ring (A) = $2 \pi r \times dl = 2 \pi r \times dr \times \text{cosec } \alpha$

Considering uniform pressure condition:

Normal load acting on the ring $dW_n = P_n \times \text{Area of the ring} = P_n \times (2 \pi r \times dr \times \text{cosec } \alpha)$

Vertical load acting on the ring = $dW = \text{vertical component of } dW_n = dW_n \times \sin \alpha$

$$= P_n \times (2 \pi r \times dr \times \text{cosec } \alpha) \times \sin \alpha = P_n \times 2 \pi r \times dr$$

$$\text{Total axial load acting on the bearing (} W) = \int_{r_2}^{r_1} P_n \times 2 \pi r \times dr$$

$$= 2 \pi P_n \times \left[\frac{r^2}{2} \right]_0^R = 2 \pi P_n \times \frac{R^2}{2} = \pi \times R^2 \times P_n$$

$$\therefore P_n = \frac{W}{\pi R^2}$$

Frictional force acting on the ring (dF) = $\mu \times W_n = \mu \times P_n \times 2 \pi r \times dr \times \text{cosec } \alpha$

Frictional torque on the ring = $dF \times r = 2 \pi \mu P_n \times \text{cosec } \alpha \times r^2 \times dr$

By integrating the above equation from 0 to R we get;

$$\text{Total frictional torque on bearing surface (} T) = \int_0^R (2 \pi \mu P_n \times \text{cosec } \alpha \times r^2 \times dr)$$

$$= 2 \pi \mu P_n \times \text{cosec } \alpha \times \left[\frac{r^3}{3} \right]_0^R$$

$$= 2 \pi \mu P_n \times \text{cosec } \alpha \times \frac{R^3}{3}$$

$$= \frac{2 \pi R^3}{3} \times \mu P_n \times \text{cosec } \alpha$$

Replacing the value of P_n we get, $T = \frac{2 \pi R^3}{3} \times \mu \times \frac{W}{\pi R^2} \times \text{cosec } \alpha$

$$\Rightarrow T = \frac{2}{3} \times \mu \times W \times R \times \text{cosec } \alpha$$

Considering uniform wear condition:

Total frictional torque acting on bearing = $T = \frac{1}{2} \times \mu \times W \times R \times \text{cosec } \alpha$

Q.17) A conical pivot with angle of cone as 100° supports a load of 18 kN. The external radius is 2.5 times the internal radius. The shaft rotates at 150 rpm. If the intensity of pressure is to be 300 kN/m^2 and coefficient of friction as 0.05, what is the power lost in working against friction?

Ans) Data Given:

Load (W) = 18 kN, semi cone angle (α) = 50° , coefficient of friction (μ) = 0.05 rpm,
 N = 150 rpm, intensity of pressure (p) = 300 kN/m^2
 External radius (r_1) = $2.5 \times$ Internal radius (r_2)

Assuming uniform pressure; $p = \frac{W}{\pi \times (r_1^2 - r_2^2)} = \frac{18 \times 10^3}{\pi \times ((2.5r_2)^2 - r_2^2)}$

$$\Rightarrow 300 \times 10^3 = \frac{18 \times 10^3}{\pi \times ((2.5r_2)^2 - r_2^2)}$$

$$\Rightarrow (2.5r_2)^2 - r_2^2 = \frac{18 \times 10^3}{300 \times 10^3 \times \pi} = 0.019$$

$$\Rightarrow 5.25r_2^2 = 0.019 \Rightarrow r_2 = 0.0601 \text{ m}$$

$$\Rightarrow r_1 = 2.5 \times 0.0601 = 0.1502 \text{ m}$$

$$\text{Torque transmitted (T)} = \frac{2}{3} \times \frac{\mu W}{\sin \alpha} \times \left[\frac{r_1^3 - r_2^3}{r_1^2 - r_2^2} \right] = \frac{2}{3} \times \frac{0.05 \times 18 \times 10^3}{\sin 50^\circ} \times \left[\frac{0.1502^3 - 0.0601^3}{0.1502^2 - 0.0601^2} \right]$$

$$= 131.6 \text{ N-m}$$

$$\text{Power lost (P)} = \frac{2\pi NT}{60} = \frac{2 \times \pi \times 150 \times 131.6}{60} = 2067 \text{ Watt}$$

Q.18) What are the functions of Clutch? Explain how it works with neat sketch.

Ans) A clutch is used to connect or disconnect the rotating shaft and driving mechanisms.

One side of the clutch is connected to the driving mechanism, and the other side is connected to the rotating shaft. When the clutch is in contact, the rotating shaft will rotate with the driving mechanism. When the clutch is separated, the driving force will not be transmitted to the rotating shaft.

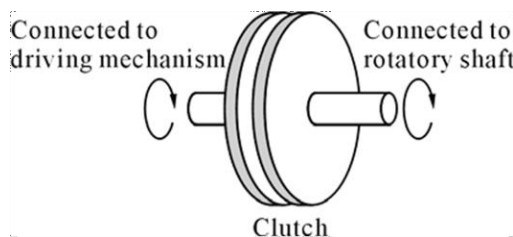

(When the clutch is in contact)

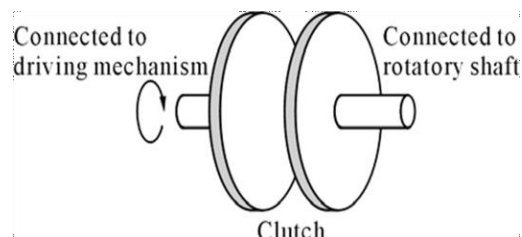

(When the clutch is separated)

Q.19) Derive the expression for torque transmission in a Single disc or plate clutch.

Ans) Torque transmission in a Single disc or plate clutch:

Consider two friction surfaces of a single plate or disc clutch as shown in figure.

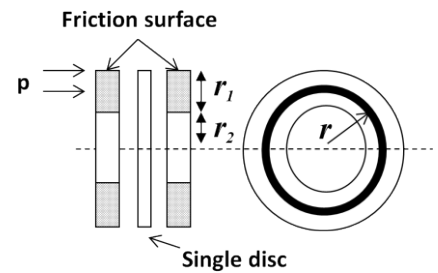

Let, W = axial thrust acting on the friction surfaces.
 p = intensity of axial pressure per unit area of contact surfaces.

r_1 = external radius of friction surface.
 r_2 = internal radius of friction surface.
 μ = coefficient of friction.

T = torque transmitted by clutch.

$$\text{Area of the contact surface (A)} = \pi [r_1^2 - r_2^2]$$

Consider a ring of radius 'r' and thickness 'dr'.

$$\text{Area of the ring} = 2 \pi r \times dr$$

$$\text{Axial load transmitted on the ring (dW)} = p \times 2 \pi r \times dr$$

$$\text{Frictional resistance acting on the ring (dF)} = \mu \times dW = 2 \pi \times \mu \times p \times r \times dr$$

$$\text{Frictional torque acting on the ring (dT)} = dF \times r = 2 \pi \times \mu \times p \times r^2 \times dr$$

Considering uniform pressure condition:

$$\text{Intensity of pressure (p)} = \frac{W}{\pi [r_1^2 - r_2^2]} \quad \text{----- (1)}$$

We know that, Frictional torque on ring (dT) = dF \times r = $2 \pi \times \mu \times p \times r^2 \times dr$

By integrating the above equation from r_2 to r_1 we get;

$$\begin{aligned} \text{Total frictional torque on contact surface (T)} &= \int_{r_2}^{r_1} (2 \pi \times \mu \times p \times r^2 \times dr) \\ &= 2 \pi \times \mu \times p \times \int_{r_2}^{r_1} (r^2 \times dr) \\ &= 2 \pi \times \mu \times p \times \left[\frac{r^3}{3} \right]_{r_2}^{r_1} \\ &= 2 \pi \times \mu \times p \times \left(\frac{r_1^3 - r_2^3}{3} \right) \end{aligned}$$

Replacing the value of 'p' from equation-1, we get:

$$\begin{aligned} \text{Total frictional torque on contact surface (T)} &= 2 \pi \times \mu \times \frac{W}{\pi [r_1^2 - r_2^2]} \times \left(\frac{r_1^3 - r_2^3}{3} \right) \\ &= \frac{2}{3} \times \mu \times W \times \left(\frac{r_1^3 - r_2^3}{r_1^2 - r_2^2} \right) = \mu \times W \times R \end{aligned}$$

$$\text{Where, } R = \frac{2}{3} \times \frac{r_1^3 - r_2^3}{r_1^2 - r_2^2} = \text{mean radius}$$

Considering uniform wear condition:

The rate of wear depends upon the intensity of pressure and velocity of rubbing surface. It is proportional to ($p \times v$), but velocity increases with distance or radius 'r'. So we can write:

$$p \cdot r = C \quad \text{or} \quad p = \frac{C}{r}$$

We know that, Load transmitted on ring = $p \times 2 \pi r \times dr = \frac{C}{r} \times 2 \pi r \times dr = 2 \pi C \times dr$

$$\text{Load transmitted to contact surface (W)} = \int_{r_2}^{r_1} (2 \pi \times C \times dr) = 2 \pi C \times [r]_{r_2}^{r_1} = 2 \pi C \times (r_1 - r_2)$$

Or $C = \frac{W}{2\pi \times (r_1 - r_2)}$ ----- (2)

We know that, Frictional torque on ring (dT) = dF × r = 2π × μ × p × r² × dr
replacing the 'p' value we get;

Frictional torque on ring (dT) = dF × r = 2π × μ × C × r × dr

By integrating the above equation from r₂ to r₁ we get;

$$\begin{aligned} \text{Total frictional torque on contact surface (T)} &= \int_{r_2}^{r_1} (2\pi \times \mu \times C \times r \times dr) \\ &= 2\pi \times \mu \times C \times \int_{r_2}^{r_1} (r \times dr) \\ &= 2\pi \times \mu \times C \times \left[\frac{r^2}{2} \right]_{r_2}^{r_1} \\ &= 2\pi \times \mu \times C \times \left(\frac{r_1^2 - r_2^2}{2} \right) \\ &= \pi \times \mu \times C \times (r_1^2 - r_2^2) \end{aligned}$$

replacing the value of 'C' from equation-2, we get

$$\begin{aligned} \text{Total frictional torque on contact surface (T)} &= \pi \times \mu \times \frac{W}{2\pi \times (r_1 - r_2)} \times (r_1^2 - r_2^2) \\ &= \frac{1}{2} \times \mu \times W \times (r_1 + r_2) = \mu \times W \times R \end{aligned}$$

where, $R = \frac{r_1 + r_2}{2}$ = mean radius

Total frictional torque acting on the friction surface is, **T = n.μ.W.R**

For single disc clutch, both sides of the disc is effective, so number of pairs in contact (n) = 2

Intensity of pressure is maximum at the inner radius (r₂), ⇒ **p_{max} × r₂ = C**

Intensity of pressure is minimum at the outer radius (r₁), ⇒ **p_{min} × r₁ = C**

Q.20) A plate clutch has ten operating faces with inner and outer diameter of 15 cm and 25 cm respectively. It runs at 1200 r.p.m with a total end load of 4500 N. The coefficient of friction is 0.08. Find the maximum torque and power that can be transmitted in KW. Assume uniform wear condition.

Ans) Data given

number of faces (n) = 10 outer diameter (D₁) = 25 cm = 0.25

mouter radius (r₁) = 0.125 m inner diameter (D₂) = 15 cm = 0.15

m

inner radius (r₂) = 0.075 m speed (N) = 1200 rpm load (W) = 4500 N

coefficient of friction (μ) = tan φ = 0.08

Torque transmitted (T) = $\frac{1}{2} \times \mu \times W (r_1 + r_2)$

$= \frac{1}{2} \times 0.08 \times 4500 \times (0.125 + 0.075) = 360 \text{ N-m}$

Power transmitted (P) = $\frac{2 \pi n T}{60} = \frac{2 \times \pi \times 1200 \times 360}{60} = 45238.9 \text{ Watt} = 45.238 \text{ kW}$ (Ans)

Q.21) A multiple disc clutch has five plates having four active pairs of frictional surface. Determine the maximum axial intensity of pressure between the disc for transmitting 18 KW at 500 r.p.m, if the outer and inner radius of frictional surface is 125 mm and 75 mm respectively. Assume uniform wear theory and coefficient of friction is 0.3.

Ans) Data given

number of active plates (n) = 4

inner radius (r₂) = 75 mm = 0.075

outer radius (r₁) = 125 mm = 0.125

maximum power (P) = 18 KW

mspeed (N) = 500 rpm

coefficient of friction (μ) = tan φ = 0.3

we know that, Power transmitted (P) = $\frac{2 \pi N T}{60}$

$$\Rightarrow 18 \times 10^3 = \frac{2 \times \pi \times 500 \times T}{60} \quad \Rightarrow \quad T = \frac{18 \times 10^3 \times 60}{2 \times \pi \times 500} = 343.77 \text{ N-m}$$

Torque transmitted (T) = $\frac{1}{2} \times \mu \times W (r_1 + r_2)$

$$\Rightarrow 343.77 = \frac{1}{2} \times 0.3 \times W (0.125 + 0.075)$$

$$\Rightarrow W = \frac{2 \times 343.77}{0.3 \times 0.2} = 2864.75 \text{ N}$$

we know that, $W = 2 \pi C \times (0.125 - 0.075)$

$$\Rightarrow C = \frac{2864.75}{2 \pi \times 0.05} = 9118.78 \text{ N/m}$$

$$P_{\max} = \frac{9118.78}{0.075} = 121583.76 \text{ N/m}^2 = 0.12158 \text{ N/mm}^2 \quad (\text{Ans})$$

Q.22) A multiple disc clutch transmits 55 KW at 1800 rpm, coefficient of friction for surfaces is 0.01 and axial intensity of pressure is not to exceed 150 KN/m². The internal radius is 80mm and is 0.7 times the external radius. Find the number of plates needed to transmit the required torque.

Ans) Data given

power (P) = 55 KW = $55 \times 10^3 \text{ W}$ coefficient of friction (μ) = $\tan \phi = 0.1$

intensity of pressure (p) = 150 K N/m² inner radius (r_2) = 80 mm = 0.08 m,

outer radius (r_1) = $0.08/0.7 \text{ mm} = 114.28 \text{ mm} = 0.114 \text{ m}$ speed (N) = 1800 rpm,

we know that, Power transmitted (P) = $\frac{2 \pi N T}{60}$

$$\Rightarrow 55 \times 10^3 = \frac{2 \times \pi \times 1800 \times T}{60}$$

$$\Rightarrow T = \frac{55 \times 10^3 \times 60}{2 \times \pi \times 1800} = 291.78 \text{ N-m}$$

Torque transmitted (T) = $\frac{1}{2} \times \mu \times W (r_1 + r_2)$

$$\Rightarrow 291.78 = \frac{1}{2} \times 0.1 \times W (0.114 + 0.08)$$

$$\Rightarrow W = \frac{2 \times 291.78}{0.1 \times 0.194} = 30080.41 \text{ N}$$

we know that, $C = \text{pressure} \times r_2 = 150 \times 10^3 \times 0.08 = 12000 \text{ N/m}$

$W = 2 \pi C \times (0.114 - 0.08) \times n$

$$\Rightarrow 30080.41 = 2 \pi \times 12000 \times (0.114 - 0.08) \times n$$

$$\Rightarrow n = \frac{30080.41}{2 \pi \times 12000 \times (0.114 - 0.08)} = 11.73 \approx 12$$

\therefore number of contact surface = 12

\therefore number of plates = $12+1 = 13$ (**Ans**)

Q.23) A multiple disc clutch has five plates having four active pairs of frictional surface. If the intensity of pressure is not to exceed 0.15 N/mm², find the power transmitted at 400 r.p.m. The outer and inner radius of frictional surface is 120 mm and 60 mm respectively. Assume uniform wear theory and coefficient of friction is 0.3.

Ans) Data given

number of active plates (n) = 4

outer radius (r_1) = 120 mm = 0.12 m

speed (N) = 400 rpm

inner radius (r_2) = 60 mm = 0.06 m

intensity of pressure (p) = 0.15 N/mm²

coefficient of friction (μ) = $\tan \phi = 0.3$

we know that, $C = \text{maximum pressure} \times r_2 = 0.15 \times 60 = 9$

$$N/\text{mmW} = 2 \pi C \times (120 - 60) = 2 \pi \times 9 \times (120 - 60) = 3392.92 \text{ N}$$

$$\begin{aligned} \text{Torque transmitted (T)} &= \frac{1}{2} \times \mu \times W (r_1 + r_2) \times n = \frac{1}{2} \times 0.3 \times 3392.92 \times (120 + 60) \times 4 \\ &= \frac{732870.72}{2} = 366435.66 \text{ N-mm} = 366.435 \text{ N-m} \end{aligned}$$

$$\text{Power transmitted (P)} = \frac{2 \pi N T}{60} = \frac{2 \times \pi \times 400 \times 366.435}{60 \times 1000} = 15.349 \text{ KW} \quad (\text{Ans})$$

Q.24) A single plate friction clutch both side effective is to transmit 12 KW at 3000 rpm. The axial pressure being limiting to 0.09 N/mm². Find the required dimension of the friction lining, assume uniform wear condition, coefficient of friction is 0.03 and external diameter is 1.4 times internal diameter.

Ans) Data given:

$$\text{Power (P)} = 12 \text{ KW} = 12 \times 10^3 \text{ W}$$

$$\text{axial pressure (p)} = 0.09 \text{ N/mm}^2$$

$$\text{speed (N)} = 3000 \text{ rpm}$$

$$\text{coefficient of friction } (\mu) = \tan \phi = 0.03$$

$$\text{external diameter (D}_1) = 1.4 \times \text{internal diameter (D}_2)$$

$$\text{external radius (r}_1) = 1.4 \times \text{internal radius (r}_2)$$

$$\text{power transmitted (P)} = \frac{2 \pi N T}{60} \Rightarrow 12 \times 10^3 = \frac{2 \times \pi \times 3000 \times T}{60}$$

$$\Rightarrow T = \frac{12 \times 10^3 \times 60}{2 \times \pi \times 3000} = 38.12 \text{ N-m} = 38.12 \times 10^3 \text{ N-mm}$$

$$\text{Torque transmitted (T)} = \frac{1}{2} \times \mu \times W (r_1 + r_2)$$

$$\Rightarrow 38.12 \times 10^3 = \frac{1}{2} \times 0.03 \times W (1.4 \times r_2 + r_2) \text{ -----(1)}$$

$$\text{We know that, } W = 2 \pi C \times (r_1 - r_2)$$

$$= 2 \times \pi \times 0.09 \times r_2 \times (1.4 \times r_2 - r_2)$$

$$= 2 \times \pi \times 0.09 \times r_2 \times (0.4 \times r_2) = 0.226 r_2^2 \text{ ----- (2)}$$

putting the values of W in equation-1, we get

$$\Rightarrow 38.12 \times 10^3 = \frac{1}{2} \times 0.03 \times 0.226 r_2^2 \times (1.4 \times r_2 + r_2)$$

$$= 8.136 \times 10^3 \times r_2^3$$

$$\Rightarrow r_2^3 = \frac{38.12 \times 10^3}{8.136 \times 10^{-3}} = 4.67 \times 10^6 \text{ mm}^3$$

$$\Rightarrow r_2 = \sqrt[3]{(4.67 \times 10^6)} = 167.14 \text{ mm}$$

$$\therefore r_1 = 1.4 \times 167.14 = 234.009 \text{ mm} \quad (\text{Ans})$$

Q.25) A single dry plate clutches transmits 7.5 KW at 900 rpm. If the coefficient of friction is 0.25 and external pressure is 0.07 N/mm², find i) mean radius and face width of the friction lining assuming the ratio of the mean radius to the face width as 4 and ii) outer and inner radius of the clutch plate.

Ans) Data given:

$$\text{Power (P)} = 7.5 \text{ KW} = 7.5 \times 10^3 \text{ W}$$

$$\text{speed (N)} = 900 \text{ rpm}$$

$$\text{external pressure (p)} = 0.07 \text{ N/mm}^2$$

$$\text{coefficient of friction } (\mu) = \tan \phi = 0.25$$

$$W = \frac{2 \pi N}{60} = \frac{2 \times \pi \times 900}{60} = 94.26 \text{ rad/s}$$

Let, R = mean radius of the friction lining in mm

b = face width of the friction lining in mm
 Ratio of mean radius to the face width = $\frac{R}{b} = 4$ (given)

Area of the friction faces (A) = $2 \pi R w$

Axial force acting on the friction faces (W) = $A \times P = 2 \pi R w P$

Assuming uniform wear, $T = n \times \mu \times W \times R = 2 \times 0.25 \times 2 \pi R w P \times R$
 $= 2 \times 0.25 \times 2 \pi R \times \frac{R}{4} \times 0.07 \times R = 0.055 R^3 \text{ N-mm} \dots (1)$

(assume n = 2, for single plate clutch)

Power transmitted (P) = $T_1 \cdot w$

$$\Rightarrow T = \frac{7.5 \times 10^3}{94.26} = 79.56 \text{ N-m} = 79.56 \times 10^3 \text{ N-mm} \dots \dots \dots (2)$$

from equation 1 and 2, we get $R^3 = \frac{7.5 \times 10^3}{0.055} = 1446.5 \times 10^3$

$$\Rightarrow R = 113 \text{ mm}$$

$$\text{or } b = 113/4 = 28.25 \text{ mm}$$

Let r_1 and r_2 are the outer and inner radius respectively.
 $b = r_1 - r_2 = 28.25 \text{ mm} \dots (3)$

Also for uniform wear condition mean radius of clutch plate (R) = $\frac{r_1 + r_2}{2}$

$$\text{or } r_1 + r_2 = 2R = 2 \times 113 = 226 \text{ mm} \dots \dots \dots (4)$$

solving 3 and 4, we get

$$\begin{array}{r} r_1 + r_2 = 226 \\ r_1 - r_2 = \\ \hline 28.25 \\ \hline \Rightarrow 2 \times r_1 = 254.5 \quad \Rightarrow r_1 = 127.25 \text{ mm} \\ \text{as } r_1 + r_2 = 226 \quad \Rightarrow r_2 = 98.75 \text{ mm} \end{array}$$

Q.26) What is the function of dynamometer? Classify.

Ans) It is used to measure the frictional resistance. By finding the frictional resistance, we can find out the torque transmitted and power absorbed.

- 1) Absorption type dynamometer – In these dynamometers the entire energy of the engine is absorbed by the frictional resistances of the brake and is transformed into heat. It is classified as: 1) prony brake dynamometer & 2) rope brake dynamometer.
- 2) Transmission dynamometers – In these dynamometers the energy is not wasted in friction but is used to do work. The energy produced by the engine is transmitted to the other machines through the dynamometers.

Q.27) Explain the working of absorption type dynamometer.

Ans) Absorption type dynamometer – In these dynamometers the entire energy of the engine is absorbed by the frictional resistances of the brake and is transformed into heat. It is classified as: 1) prony brake dynamometer & 2) rope brake dynamometer.

Prony brake dynamometer:

An absorption type prony brake dynamometer is shown in figure. It consists of two wooden blocks placed around a pulley. It is fixed with the engine shaft. The blocks are clamped by nut and bolts. A helical spring is provided between nut and upper block to control the pressure on the pulley or to control its speed. A long lever is attached to the upper block, which carries weights at its outer end. A counter weight is provided at the other end of lever to balance the brake when unloaded. Two stops ‘S’ is provided to limit the motion of the lever.

When the brake comes in action, the long end of lever is loaded with weights W and nuts are tightened until the engine shaft runs at mean speed and lever lies in horizontal position. For this case the moment due to weight W must be balance the moment of frictional resistance between the blocks and the pulley.

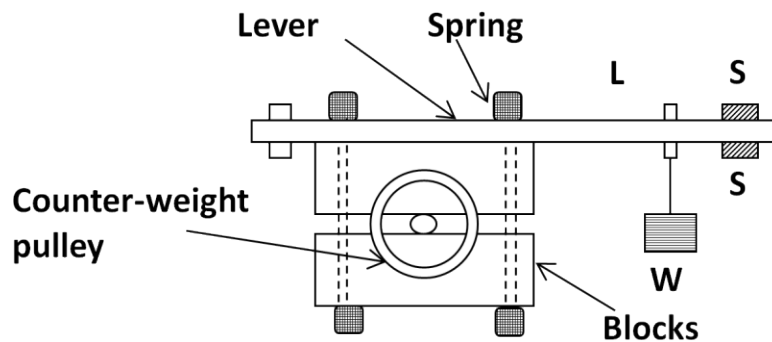

(Prony brake dynamometer)

- Let, W = weight at the outer end of lever in N
 L = horizontal distance of weight W from centre of pulley in metres
 F = frictional resistance between block and pulley in N
 R = radius of pulley in metres
 N = speed of shaft in r.p.m

Moment of frictional resistance or torque on shaft (T) = $W.L = F.R$ N-m

Work done in one revolution = torque \times angle turned in radian
 $= T \times 2\pi$ N-m

Work done per minute = $T \times 2\pi \times N$ N-m

Brake power of the engine = $B.P = \frac{\text{work done per minute}}{60} = \frac{T \times 2\pi N}{60} = \frac{W \times L \times 2\pi N}{60}$

Rope brake dynamometer:

It is most common dynamometer which is used to measure the brake power of the engine. It consists of one, two or more ropes wound around the fly wheel or rim of the pulley which is fixed to the shaft of the engine. The upper end of the shaft is attached to a spring balance and the lower end of the rope is attached with a dead weight. Wooden blocks are provided in the intervals around the circumference of flywheel to prevent the slipping of rope from flywheel.

- Let, W = dead load in N
 S = spring balance reading in N
 D = diameter of wheel in 'm'
 d = diameter of rope in 'm'
 N = speed of the engine in r.p.m
 Net load on the brake = $(W - S)$ in N

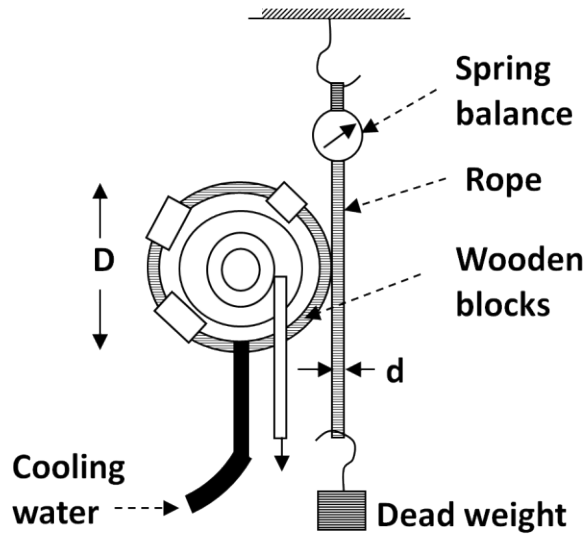

(Rope brake dynamometer)

Distance moved in one revolution = $\pi (D + d)$ in m

Work done per revolution = $(W - S) \pi (D + d) N$ in N-m

Brake power (B.P) = $\frac{\text{work done per minute}}{60} = \frac{(W - S) \pi (D + d) N}{60}$ in Watts

If the diameter of the rope is neglected, then **B.P** = $\frac{(W - S) \pi D N}{60}$ in Watts

The frictional torque due to rope equals to torque transmitted by the engine.

Q.28) What is the function of frictional brakes.

Ans) A brake is a device which is used to offer frictional resistance to moving machine elements to stop the motion of the element or retard its motion. It absorbs the kinetic or potential energy when applied.

ASSIGNMENT

- Q.1) A thrust bearing has four collars of 600 mm diameter and 250 mm internal diameter. The total thrust from the shaft is 80 kN. If the coefficient of friction is 0.2 and engine speed is 100 r.p.m. Find the power absorbed in friction, assuming **i)** uniform wear **ii)** uniform pressure.
- Q.2) A shaft has a number of collars integral with it. The external diameter of the collars is 400 mm and the shaft diameter is 250 mm. If the uniform intensity of pressure is 0.35 N/mm^2 and the coefficient of friction is 0.05, estimate: **1)** Power absorbed when shaft runs at 105 r.p.m carrying a load of 150 kN; and **2)** Number of collars required.
- Q.3) A conical pivot bearing 150 mm diameter has a cone angle of 120° . If the shaft supports an axial load of 20 kN and the coefficient of friction is 0.03, find the power lost in friction when the shaft rotates at 200 r.p.m, assuming **1)** uniform wear **2)** uniform pressure.
- Q.4) A conical pivot supports a load of 20 kN, the cone angle is 120° and the intensity of normal pressure is not exceed 0.3 N/mm^2 . The external diameter is twice the internal diameter. Find the outer and inner radii of the bearing surface. If the shaft rotates at 200 r.p.m and the coefficient of friction is 0.1, find the power absorbed in friction. Assume uniform pressure.
- Q.5) A conical pivot bearing supports a vertical shaft of 200 mm diameter. It is subjected to a load of 30 kN. The angle of the cone is 120° and the coefficient of friction is 0.025. Find the power lost in friction when the speed is 140 r.p.m, assuming **1)** Uniform pressure; and **2)** Uniform wear.

END of Chapter

POWER TRANSMISSION

Q.1) Define the velocity ratio of the belt drive. State its expressions.

Ans) It is defined as the ratio between the velocities of driver and driven or follower.

Mathematically it may be expressed as - $\frac{N_2}{N_1} = \frac{d_1}{d_2}$

where, N_2 = speed of the follower,
 d_1 = diameter of the driver,

N_1 = speed of the driver,
 d_2 = diameter of the follower

If the thickness (t) of the belt is considered,
 then velocity ratio is expressed as -

$$\frac{N_2}{N_1} = \frac{d_1 + t}{d_2 + t}$$

If the thickness (t) and slip (s) both are considered,

then the velocity ratio is expressed as - $\frac{N_2}{N_1} = \frac{d_1 + t}{d_2 + t} \left(1 - \frac{s}{100}\right)$

where, N_1 = speed of the pulley-1 in r.p.m, N_2 = speed of the pulley-2 in r.p.m,
 d_1 = diameter of the pulley-1, d_2 = diameter of the pulley-2
 s = slip between the belt and pulley, t = thickness of belt

Q.2) State the expression for the length of an open belt drive.

Ans) It is given by the relation - $L = \pi (r_1 + r_2) + 2x + \frac{(r_1 - r_2)^2}{x}$

where, r_1 = radius of larger pulley

r_2 = radius of smaller pulley

x = distance between the centre of two pulleys

L = length of belt

Q.3) State the expression for the length of a cross belt drive.

Ans) It is given by the relation - $L = \pi (r_1 + r_2) + 2x + \frac{(r_1 + r_2)^2}{x}$

where, r_1 = radius of larger pulley

r_2 = radius of smaller pulley

x = distance between the centre of two pulleys

L = length of belt

Q.4) State the expression for ratio of tension in belt drive.

Ans) It is given by the relation - $\frac{T_1}{T_2} = e^{\mu\theta}$

where, T_1 = tension in tight side in N

T_2 = tension in slack side in N

μ = coefficient of friction

θ = angle of lap

Q.5) State the expression for centrifugal tension in belt drive.

Ans) It is given by the relation - $T_c = mV^2$

where, T_c = centrifugal tension in N

m = mass of the belt per unit length in Kg

V = velocity of the belt in m/s

r = radius of the pulley over which the belt runs.

Q.6) State the condition for maximum power transmission in belt drive.

Ans) It is given by the relation - $T = 3 T_c$

where, T = maximum tension in N

T_c = centrifugal tension in N

Q.7) State the expression for power transmitted in a belt drive.

Ans) It is given by the relation - $P = (T_1 - T_2) \times v$ N-m/s (1 N-m/s = 1 watt)

where, T_1 = tension in the tight side of the belt in N

T_2 = tension in the slack side of the belt in N

v = velocity of the belt in m/s

Q.8) Derive an expression for length of an open belt drive.

Ans) Consider an open belt drive as shown in figure.

Let, r_1 and r_2 are the radii of larger and smaller pulley, x = distance between the centres of two pulleys and L = total length of the belt.

Let, O_2M parallel to EF and perpendicular to O_1E .

Angle $MO_2O_1 = \alpha$

$$\text{so, } \sin \alpha = \frac{O_1M}{O_1O_2} = \frac{O_1E - EM}{O_1O_2} = \frac{r_1 - r_2}{x}$$

$$\text{since } \alpha \text{ is very small so } \sin \alpha = \alpha = \frac{r_1 - r_2}{x}$$

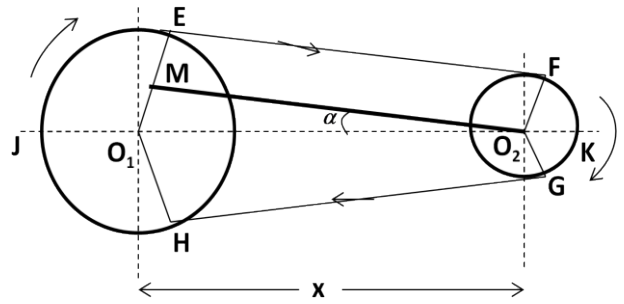

(Open belt drive)

$$\begin{aligned} \text{In figure total length of belt (L)} &= (2 \times \text{arc JE}) + EF + (2 \times \text{arc FK}) + GH \\ \Rightarrow L &= (2 \times \text{arc JE}) + EF + (2 \times \text{arc FK}) + GH \\ \Rightarrow L &= (2 \times \text{arc JE}) + (2 \times EF) + (2 \times \text{arc FK}) \\ \Rightarrow L &= 2 [\text{arc JE} + EF + \text{arc FK}] \end{aligned}$$

$$\text{We know that, } \text{arc JE} = r_1 \times \left(\frac{\pi}{2} + \alpha\right) \quad \text{arc FK} = r_2 \times \left(\frac{\pi}{2} - \alpha\right)$$

$$\begin{aligned} EF = MO_2 &= \sqrt{(O_1O_2)^2 - (O_1M)^2} \\ &= \sqrt{x^2 - \left(\frac{r_1 - r_2}{2}\right)^2} = x \sqrt{1 - \frac{(r_1 - r_2)^2}{x^2}} \end{aligned}$$

Expanding this equation by binomial theorem, we get

$$EF = x \times \left[1 - \frac{1}{2} \frac{(r_1 - r_2)^2}{x^2} + \dots\right] = x - \frac{(r_1 - r_2)^2}{2x}$$

Putting the all the obtained values in the below equation, we get

$$\begin{aligned} \Rightarrow L &= 2 \left[r_1 \times \left(\frac{\pi}{2} + \alpha\right) + x - \frac{(r_1 - r_2)^2}{2x} + r_2 \times \left(\frac{\pi}{2} - \alpha\right) \right] \\ &= 2 \left[r_1 \times \frac{\pi}{2} + r_1 \times \alpha + x - \frac{(r_1 - r_2)^2}{2x} + r_2 \times \frac{\pi}{2} - r_2 \times \alpha \right] \\ &= 2 \left[\frac{\pi}{2} (r_1 + r_2) + \alpha (r_1 - r_2) + x - \frac{(r_1 - r_2)^2}{2x} \right] \\ &= \pi (r_1 + r_2) + 2 \alpha (r_1 - r_2) + 2x - \frac{(r_1 - r_2)^2}{x} \\ &= \pi (r_1 + r_2) + 2 \times \frac{r_1 - r_2}{x} (r_1 - r_2) + 2x - \frac{(r_1 - r_2)^2}{x} \quad \text{(The value of } \alpha \text{ is replaced)} \\ &= \pi (r_1 + r_2) + \frac{2(r_1 - r_2)^2}{x} + 2x - \frac{(r_1 - r_2)^2}{x} \end{aligned}$$

$$\Rightarrow L = \pi (r_1 + r_2) + 2x + \frac{(r_1 - r_2)^2}{x} \quad \text{----- (in terms of pulley radii)}$$

$$\Rightarrow L = \frac{\pi}{2} (d_1 + d_2) + 2x + \frac{(d_1 - d_2)^2}{4x} \quad \text{----- (in terms of pulley diameter)}$$

Q.9) Derive an expression for length of a crossed belt drive.

Consider a crossed belt drive as shown in figure.

Let, r_1 and r_2 are the radii of larger and smaller pulley, x = distance between the centres of two pulleys and L = total length of the belt.

Let, O_2M parallel to EF and perpendicular to O_1E .

Angle $M O_2 O_1 = \alpha$

$$\text{so, } \sin \alpha = \frac{O_1M}{O_1O_2} = \frac{O_1E + EM}{O_1O_2} = \frac{r_1 + r_2}{x}$$

$$\text{since } \alpha \text{ is very small so } \sin \alpha = \alpha = \frac{r_1 + r_2}{x}$$

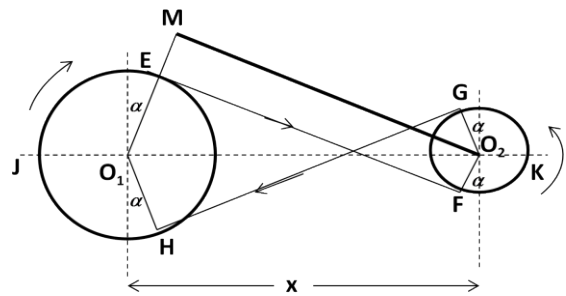

(Crossed belt drive)

In figure total length of belt (L) = $(2 \times \text{arc JE}) + EF + (2 \times \text{arc FK}) + GH$

$$\Rightarrow L = (2 \times \text{arc JE}) + EF + (2 \times \text{arc FK}) + GH$$

$$\Rightarrow L = (2 \times \text{arc JE}) + (2 \times EF) + (2 \times \text{arc FK})$$

$$\Rightarrow L = 2 [\text{arc JE} + EF + \text{arc FK}]$$

We know that, $\text{arc JE} = r_1 \times (\frac{\pi}{2} + \alpha)$ $\text{arc FK} = r_2 \times (\frac{\pi}{2} + \alpha)$

$$EF = M O_2 = \sqrt{(O_1O_2)^2 - (O_1M)^2} = \sqrt{x^2 - (r_1 - r_2)^2}$$

$$= x \sqrt{1 - \frac{(r_1 - r_2)^2}{x^2}}$$

Expanding this equation by binomial theorem, we get

$$EF = x \times [1 - \frac{1}{2} \frac{(r_1 - r_2)^2}{x^2} + \dots] = x - \frac{(r_1 - r_2)^2}{2x}$$

Putting the all the obtained values in the below equation, we get

$$\begin{aligned} \Rightarrow L &= 2 \left[r_1 \times \left(\frac{\pi}{2} + \alpha \right) + x - \frac{(r_1 - r_2)^2}{2x} + r_2 \times \left(\frac{\pi}{2} + \alpha \right) \right] \\ &= 2 \left[r_1 \times \frac{\pi}{2} + r_1 \times \alpha + x - \frac{(r_1 - r_2)^2}{2x} + r_2 \times \frac{\pi}{2} + r_2 \times \alpha \right] \\ &= 2 \left[\frac{\pi}{2} (r_1 + r_2) + \alpha (r_1 + r_2) + x - \frac{(r_1 - r_2)^2}{2x} \right] \\ &= \pi (r_1 + r_2) + 2 \alpha (r_1 + r_2) + 2x - \frac{(r_1 - r_2)^2}{x} \\ &= \pi (r_1 + r_2) + 2 \times \frac{r_1 + r_2}{x} (r_1 - r_2) + 2x - \frac{(r_1 - r_2)^2}{x} \quad \text{(The value of } \alpha \text{ is replaced)} \\ &= \pi (r_1 + r_2) + 2 \times \frac{(r_1 + r_2)(r_1 - r_2)}{x} + 2x - \frac{(r_1 - r_2)^2}{x} \end{aligned}$$

$$\Rightarrow L = \pi (r_1 + r_2) + 2x + \frac{(r_1 + r_2)^2}{x} \quad \text{----- (in terms of pulley radii)}$$

$$\Rightarrow L = \frac{\pi}{2} (d_1 + d_2) + 2x + \frac{(d_1 + d_2)^2}{4x} \quad \text{----- (in terms of pulley diameter)}$$

Q.10) Derive an expression for ratio of driving tension for a belt drive.

Ans) Consider a driven pulley rotating in clockwise direction as shown in figure.

Let, T_1 = tension in tight side, T_2 = tension in slack-side, θ = angle of contact in radian

Now consider a small portion of the belt PQ, which subtends with an angle $\delta\theta$ at the centre of the pulley. The belt PQ remains in equilibrium under the action following forces.

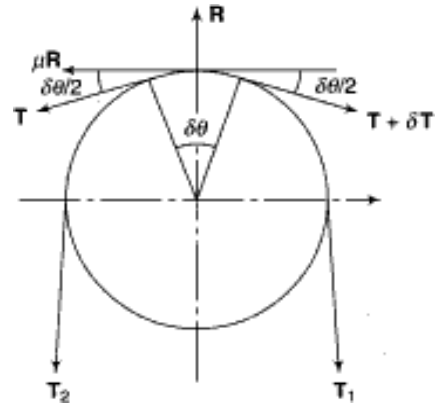

Tension T in the belt

Tension ($T + \delta T$)

Normal reaction R_N

Frictional force $F = \mu R_N$

Resolving the forces horizontally, $\Rightarrow R_N = (T + \delta T) \sin \frac{\delta\theta}{2} + T \sin \frac{\delta\theta}{2}$ ----- (1)

since the angle $\delta\theta$ is very small, considering $\sin \frac{\delta\theta}{2} = \frac{\delta\theta}{2}$ in equation-1, we get

$R_N = (T + \delta T) \times \frac{\delta\theta}{2} + T \times \frac{\delta\theta}{2} = T \times \delta\theta$ ----- (2), (neglecting the smaller terms)

Resolving the forces vertically, $\Rightarrow \mu R_N = (T + \delta T) \cos \frac{\delta\theta}{2} - T \cos \frac{\delta\theta}{2}$ ----- (3)

since the angle $\delta\theta$ is very small, considering $\cos \frac{\delta\theta}{2} = 1$, in equation-3, we get

$\mu R_N = T + \delta T - T = \delta T$ ----- (4)

From equation 2 and 4, we get, $\mu \times T \times \delta\theta = \delta T$

$\Rightarrow T \times \delta\theta = \frac{\delta T}{\mu} \Rightarrow \frac{\delta T}{T} = \mu \times \delta\theta$

Integrating both sides between the limits T_2 and T_1 and from 0 to θ , we get

$\int_{T_2}^{T_1} \frac{\delta T}{T} = \mu \times \int_0^\theta \delta\theta$
 $\Rightarrow \log_e \left(\frac{T_1}{T_2} \right) = \mu \theta$ ----- (5)

$\Rightarrow \frac{T_1}{T_2} = e^{\mu \theta}$ ----- (6)

$\Rightarrow 2.3 \log \left(\frac{T_1}{T_2} \right) = \mu \theta$ ----- (7)

Q.11) State the expression for angle of contact or lap (θ).

Ans) For an open belt drive, $\theta = (180^\circ - 2\alpha) \times \frac{\pi}{180}$ radian

For a crossed belt drive, $\theta = (180^\circ + 2\alpha) \times \frac{\pi}{180}$ radian

Q.12) What do you mean by slip and creep in belt.

Ans) SLIP - There is a firm frictional grip between the belt and pulley, but in some time due to insufficient frictional grip, some forward motion of the driver without carrying the belt or some forward motion of the belt without carrying the driven pulley occurs. This is called slip of the belt.

CREEP – When a belt passes over pulleys it expands or contracts due to which a relative motion takes place between the belt and pulley. This relative motion reduces slightly the speed of driven pulley which is known as creep in belt.

Q.13) Derive an expression for centrifugal tension in belt drive.

Ans) The tension caused by centrifugal force is called centrifugal tension.

- Let, m = mass of the belt per unit length in Kg
 v = velocity of the belt in m/s
 r = radius of the pulley in m
 T_c = centrifugal tension in N

Length of the belt PQ = $r \cdot d\theta$

Mass of the belt PQ = $m \cdot r \cdot d\theta$

Centrifugal force acting on the belt PQ,

$$F_c = (m \cdot r \cdot d\theta) \frac{v^2}{r} = m \cdot d\theta \cdot v^2$$

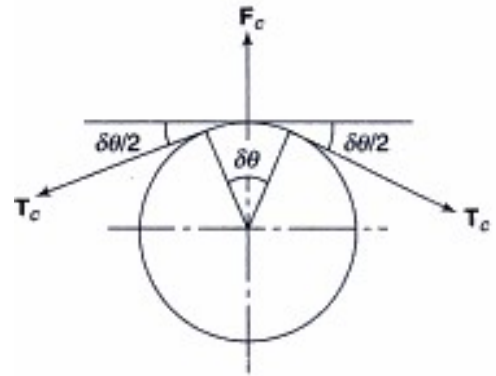

Resolving the forces horizontally, we get

$$T_c \sin \frac{d\theta}{2} + T_c \sin \frac{d\theta}{2} = m \cdot d\theta \cdot v^2$$

Since $\frac{d\theta}{2}$ is very small, considering $\sin \frac{d\theta}{2} = \frac{d\theta}{2}$, we get

$$T_c \times \frac{d\theta}{2} + T_c \times \frac{d\theta}{2} = m \cdot d\theta \cdot v^2$$

$$\Rightarrow 2 \times T_c \times \frac{d\theta}{2} = m \cdot d\theta \cdot v^2$$

$$\Rightarrow T_c = m \cdot v^2$$

Q.14) What do you mean by initial tension in belt? State its expression.

Ans) Initial tension:

Initial tension in the belt without considering centrifugal tension is: $T_0 = \frac{T_1 + T_2}{2}$

Initial tension in the belt considering centrifugal tension is: $T_0 = \frac{T_1 + T_2 + T_c}{2}$

Q.15) What is the expression for velocity of the belt for maximum power transmission?

Ans) The velocity of the belt for maximum power transmission is: $v = \sqrt{\frac{T}{3m}}$

Q.16) Find the width of the belt to transmit 7.5 KW to a pulley 300 mm diameter, if the pulley makes 1600 rpm, coefficient of friction is 0.22. Assume angle of friction is 210° and maximum tension is not to exceed 8 N/mm widths.

Ans) Data given

Power (P) = 7.5 KW = 7500 Watt

pulley diameter (D) = 300 mm = 0.3 m

speed (N) = 1600 rpm

coefficient of friction (μ) = 0.22

angle of contact (θ) = $210^\circ = 210 \times \frac{\pi}{180} = 3.665$ rad

maximum tension (T) = 8 N/mm widths

we know that, $v = \frac{\pi DN}{60} = \frac{\pi \times 0.3 \times 1600}{60} = 25.132$ m/s

$$\Rightarrow \frac{T_1}{T_2} = e^{\mu \theta} = e^{(0.22 \times 3.665)} = 2.239 \quad \Rightarrow T_1 = 2.239 \times T_2 \text{-----(1)}$$

Power transmitted (P) = $(T_1 - T_2) \times v$ N-m/s

$$\Rightarrow 7500 = (2.239 \times T_2 - T_2) \times 25.132 \quad \Rightarrow 7500 = 1.239 T_2 \times 25.132$$

$$\Rightarrow T_2 = \frac{7500}{1.239 \times 25.132} = 240.85 \text{ N} \quad \Rightarrow T_1 = 2.239 \times 240.85 = 539.28 \text{ N}$$

$$\therefore \text{width of the belt (b)} = \frac{539.28}{8} = 67.41 \text{ mm} \quad (\text{Ans})$$

Q.17) A leather belt is required to transmit 7.5 KW from a pulley 1.2 m in diameter running at 250 rpm. The angle embraced is 165° and coefficient of friction is 0.3. If the safe working stress for the leather belt is 1.5 MPa and the thickness of belt is 10 mm, determine the width of the belt required.

Ans) Data given

$$\text{Power (P)} = 7.5 \text{ KW} = 7500 \text{ Watt}$$

$$\text{pulley diameter (D)} = 1.2 \text{ m}$$

$$\text{speed (N)} = 250 \text{ rpm}$$

$$\text{coefficient of friction } (\mu) = 0.3$$

$$\text{angle of contact } (\theta) = 165^\circ = 165 \times \frac{\pi}{180}$$

$$= 2.879 \text{ rad}$$

$$\text{safe working stress } (\sigma) = 1.5 \text{ MPa} = 1.5 \times 10^6 \text{ N/m}^2$$

$$\text{thickness of the belt (t)} = 10 \text{ mm}$$

$$\text{we know that, } v = \frac{\pi DN}{60} = \frac{\pi \times 1.2 \times 250}{60} = 15.70 \text{ m/s}$$

$$\Rightarrow \frac{T_1}{T_2} = e^{\mu \theta} = e^{(0.3 \times 2.879)} = 2.372 \quad \Rightarrow \quad T_1 = 2.372 \times T_2 \text{----- (1)}$$

$$\text{Power transmitted (P)} = (T_1 - T_2) \times v \text{ N-m/s}$$

$$\Rightarrow 7500 = (2.372 \times T_2 - T_2) \times 15.70 \quad \Rightarrow \quad 7500 = 1.372 T_2 \times 15.70$$

$$\Rightarrow T_2 = \frac{7500}{1.372 \times 15.70} = 348.182 \text{ N} \quad \Rightarrow \quad T_1 = 2.372 \times 348.182 = 825.88 \text{ N}$$

$$\text{We know that } T_1 = \sigma b t$$

$$\Rightarrow 825.88 = 1.5 \times 10^6 \times b \times 0.01 \quad \Rightarrow \quad b = \frac{825.88}{1.5 \times 10^6 \times 0.01} = 0.05505 \text{ m}$$

$$\therefore \text{width of the belt (b)} = 0.05505 \times 1000 = 55.05 \text{ m} \quad (\text{Ans})$$

Q.18) A pulley is driven by a flat belt running at a speed of 600 m/min. The coefficient of friction is 0.3 and the angle of lap is 160° . The maximum tension in the belt is 700 N. Find the power transmitted in the belt.

Ans) Data given

$$\text{speed (v)} = 600 \text{ m/min} = (600/60) \text{ m/s} = 10 \text{ m/s}$$

$$\text{coefficient of friction } (\mu) = 0.3$$

$$\text{angle of lap } (\theta) = 160^\circ = 160 \times \frac{\pi}{180} = 2.792 \text{ rad}$$

$$\text{maximum tension (T)} = 700 \text{ N}$$

Let P = power transmitted in the belt.

$$\text{We know that, } \frac{T_1}{T_2} = e^{\mu \theta} = e^{(0.3 \times 2.792)} = 2.3108$$

$$\Rightarrow T_1 = 2.3108 \times T_2 \text{----- (1)} \quad \Rightarrow \quad T_2 = \frac{700}{2.3108} = 302.925 \text{ N}$$

$$\text{Power transmitted (P)} = (T_1 - T_2) \times v \text{ N-m/s}$$

$$\Rightarrow P = (700 - 302.925) \times 10 = 3970.75 \text{ W} = 3.97 \text{ KW} \quad (\text{Ans})$$

Q.19) A leather belt 125 mm wide and 6 mm thick transmits power from a pulley 750 mm diameter which runs at 500 rpm. The angle of lap is 150° and coefficient of friction is 0.3. If the density of leather is 1 Mg/m^3 and the stress in the belt is not to exceed 2.75 MPa, find the maximum power that can be transmitted.

Ans) Data given

$$\text{width (b)} = 125 \text{ mm} = 0.125 \text{ m}$$

$$\text{thickness (t)} = 6 \text{ mm} = 0.006 \text{ m}$$

$$\text{diameter (D)} = 750 \text{ mm}$$

$$\text{speed (N)} = 500 \text{ rpm}$$

$$\text{coefficient of friction } (\mu) = 0.3$$

$$\text{angle of lap } (\theta) = 150^\circ = 150 \times \frac{\pi}{180} = 2.617 \text{ rad}$$

$$\text{density } (\rho) = 1 \text{ Mg/m}^3 = 10^6 \text{ g/m}^3 = 1000 \text{ Kg/m}^3$$

$$\text{stress } (\sigma) = 2.75 \text{ MPa} = 2.75 \times 10^6 \text{ N/m}^2$$

$$\text{we know that, } v = \frac{\pi DN}{60} = \frac{\pi \times 0.75 \times 500}{60} = 19.635 \text{ m/s}$$

$$\text{maximum tension in the belt (T)} = \sigma b t = 2.75 \times 10^6 \times 0.125 \times 0.006 = 2062.5 \text{ N}$$

$$\text{mass of belt per meter length (m)} = \rho \times (b \times t \times l) = 1000 \times 0.125 \times 0.006 \times 1 = 0.75 \text{ Kg/m}$$

$$\text{we know that for maximum power transmission, } v = \sqrt{\frac{T}{3m}} = \sqrt{\frac{2062.5}{3 \times 0.75}} = 30.276 \text{ m/s}$$

condition of maximum power transmission, $\Rightarrow T_c = \frac{2062.5}{3} = 687.5 \text{ N}$

$$T_1 = T - T_c = 2062.5 - 687.5 = 1375 \text{ N}$$

We know that, $\frac{T_1}{T_2} = e^{\mu \theta}$

$$\Rightarrow \frac{1375}{T_2} = e^{\mu \theta} = e^{(0.3 \times 2.617)} = 2.1926 \Rightarrow T_2 = \frac{1375}{2.1926} = 627.109 \text{ N}$$

We know that, $P = (1375 - 626.109) \times 30.276$
 $\Rightarrow P = 22643.42 \text{ Watt} \quad (\text{Ans})$

Q.20) The power transmitted between two shafts 3.5 m apart by a cross belt drive round the two pulleys 600 mm and 300 mm in diameter is 6 KW. The speed of the larger pulley is 220 rpm. The permissible load on the belt is 25 N/mm width of the belt which is 5 mm thick. The coefficient of friction is 0.35. Determine (i) necessary length of the belt (ii) width of the belt (iii) initial belt tension.

Ans) Data given

distance between the shafts (x) = 3.5 m diameter (D₁) = 600 mm = 0.6 m
 mdiameter (D₂) = 300 mm = 0.3 m power (P) = 6 KW = 6000 Watt
 speed (N₁) = 220 rpm coefficient of friction (μ) = 0.3
 permissible load (T) = 10 N/mm Width thickness (t) = 5 mm = 0.005 m

$$\text{length of the belt (L)} = \pi (r_1 + r_2) + 2x + \frac{(r_1 + r_2)^2}{x}$$

$$r_1 = 0.3 \text{ m}, r_2 = 0.15 \text{ m}$$

$$= \pi (0.3 + 0.15) + 2 \times 3.5 + \frac{(0.3 + 0.15)^2}{3.5}$$

$$= 1.4137 + 7 + 0.0578$$

$$= 8.4715 \text{ m} \quad (\text{Ans})$$

$$\sin \alpha = \frac{r_1 + r_2}{x} = \frac{0.3 + 0.15}{3.5} = 0.1285$$

$$\Rightarrow \alpha = \sin^{-1} 0.1285 = 7.38^\circ$$

$$\Rightarrow 2\alpha = 14.76^\circ$$

In case of cross belt drive angle of lap (θ) = 180° + 2α = 180 + 14.76° = 194.76°

$$\Rightarrow \theta = 194.76^\circ \times \frac{\pi}{180} = 3.39 \text{ rad}$$

We know that, $\frac{T_1}{T_2} = e^{\mu \theta} = e^{(0.35 \times 3.35)} = 3.285$

$$\Rightarrow T_1 = 3.285 \times T_2 \quad \text{-----(1)}$$

we know that, $v = \frac{\pi DN}{60} = \frac{\pi \times 0.6 \times 220}{60} = 6.9 \text{ m/s}$

Power transmitted (P) = (T₁ - T₂) × v N-m/s

$$\Rightarrow 6000 = (3.285 \times T_2 - T_2) \times 6.9 \Rightarrow 6000 = 2.285 T_2 \times 6.9$$

$$\Rightarrow T_2 = \frac{6000}{2.285 \times 6.9} = 380.55 \text{ N} \Rightarrow T_1 = 3.285 \times 380.55 = 1250.11 \text{ N}$$

If b = width of belt

$$\text{Then } b = \frac{T_1}{25} = \frac{1250.11}{25} = 50.004 \text{ mm}$$

$$\text{Initial tension in belt (T}_0\text{)} = \frac{T_1 + T_2}{2} = \frac{1250.11 + 380.55}{2} = 815.33 \text{ N} \quad (\text{Ans})$$

Q.21) Write a short note on V-belt and V-belt pulley.

Ans) These are used where large amount of power transmission is required. V – Belts are made endless, so there is no problem of joints. The distance between the pulleys is small. The rim of the pulley is grooved in which the belt runs. This groove increases the frictional grip of the V-belt on the pulley and reduces the chance of slipping. For a good grip the V-belt is in contact with the side faces of the groove of pulley.

Q.22) What do you mean by crowning of pulley?

Ans) In general the rim of the pulley is not a circular surface, but it is a conical or convex surface to avoid the slipping of the belt from the pulley. This is known as crowning of pulleys. The amount of crowning is 1/96 of the pulley face width.

Q.23) Define circular pitch, diametral pitch and module of a gear.

Ans) Circular pitch:

It is the distance measured on the circumference of the pitch circle from a point of one tooth to the corresponding point on the next tooth. It is denoted by (p_c).

Mathematically, *Circular pitch* (p_c) = $\frac{\pi D}{T}$, where D = pitch circle diameter,

T = number of teeth on wheel

Diametral pitch:

It is the ratio of number of teeth to the pitch circle diameter in millimetres.

It is denoted by (p_d). Mathematically, *Diametral pitch* (p_d) = $\frac{T}{D} = \frac{\pi}{p_c}$,

where D = pitch circle diameter, T = number of teeth

Module:

It is the ratio of the pitch circle diameter in millimeters to the number of teeth. It is

denoted by (m). Mathematically, *Module* (m) = $\frac{D}{T}$

Q.24) Explain the working of Simple gear train.

Ans) In simple gear train each shaft supports one gear. In figure, gear 1 is called driver, gear 2 is called intermediate gear and gear 3 is called driven gear.

When the gear-1 rotates clockwise, it revolves gear-2 in anticlockwise direction and gear-2 revolves gear-3 in clockwise direction. If number of gears are odd then driver and driven gears are revolve in same direction and if number of gears are even then driver and driven gears are revolve in opposite direction.

Velocity ratio:

Let N_1 = speed of gear 1, N_2 = speed of gear

2, N_3 = speed of gear 3, T_1 = number of

teeth of gear 1, T_2 = number of teeth of

gear 2, and T_3 = number of teeth of gear

3.

$$\text{Velocity ratio of gear 1 and 2} = \frac{N_1}{N_2} = \frac{T_2}{T_1}$$

$$\text{Velocity ratio of gear 2 and 3} = \frac{N_2}{N_3} = \frac{T_3}{T_2}$$

Multi plying the above two relation we get,

$$\frac{N_1}{N_2} \times \frac{N_2}{N_3} = \frac{T_2}{T_1} \times \frac{T_3}{T_2} \quad \text{or} \quad \frac{N_1}{N_3} = \frac{T_3}{T_1}$$

$$\text{Velocity ratio} = \frac{\text{speed of driver}}{\text{speed of driven}} = \frac{\text{No.of teeth on driven}}{\text{No.of teeth on driver}}$$

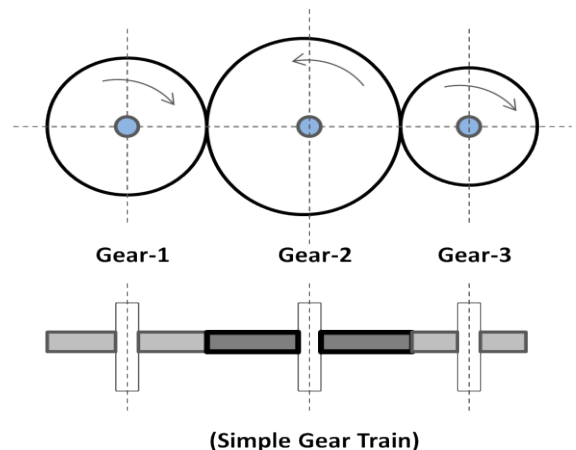

(Simple Gear Train)

Q.25) Explain the working of Compound gear train.

Ans) In a compound gear train, each shaft supports more than one gear except the first and the last shaft.

In figure, gear-1 is the first driver which revolves gear-2. Gear-2 and gear-3 are mounted on same shaft, so their speed is same ($N_2=N_3$) and direction of rotation is also same. Gear-3 is the driver of gear-4, the last driven.

Velocity ratio:

Let N_1 = speed of gear 1(driver), T_1 = number of teeth on gear 1
 N_2, N_3, N_4 = respective speed of gears
 T_2, T_3, T_4 = number of teeth on respective gears.

Considering gear1 and 2, $\frac{N_2}{N_1} = \frac{d_1}{d_2} = \frac{T_1}{T_2}$ ----- (1)

Considering gear3 and 4, $\frac{N_4}{N_3} = \frac{d_3}{d_4} = \frac{T_3}{T_4}$ ----- (2)

Multiplying 1 and 2, we get

$$\frac{N_2}{N_1} \times \frac{N_4}{N_3} = \frac{d_1}{d_2} \times \frac{d_3}{d_4} = \frac{T_1}{T_2} \times \frac{T_3}{T_4}$$

i.e. **Velocity ratio** = $\frac{\text{speed of the first driver}}{\text{speed of the last driven}}$
 = $\frac{\text{Product of the number of teeth on drivers}}{\text{Product of the number of teeth on driven}}$

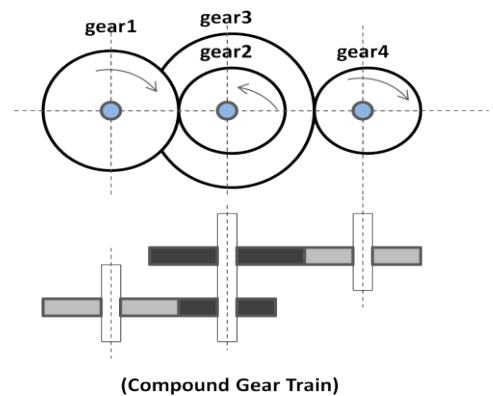

Q.26) Explain the working of Reverted gear train.

Ans) In a reverted gear train the driving and the driven gears are coaxial or coincident.

In figure, gear-1 is meshed with gear-2 and gear-3 meshed with gear-4. Gear-1 and gear-4 are mounted on same shaft. Gear-2 and gear-3 are mounted on same shaft. Gear-1 revolves gear-2 and gear-3 revolves gear-4.

Velocity ratio:

Let , N_1 = speed of gear 1(driver),

T_1 = number of teeth on gear 1

r_1 = pitch circle radius of gear 1

1

N_2, N_3, N_4 = speed of respective gears

T_2, T_3, T_4 = number of teeth on respective gears and

r_2, r_3 and r_4 = pitch circle radii of respective gears

Considering gear 1 and 2, we get $\frac{N_2}{N_1} = \frac{d_1}{d_2} = \frac{T_1}{T_2}$ ----- (1)

Considering gear 3 and 4, we get $\frac{N_4}{N_3} = \frac{d_3}{d_4} = \frac{T_3}{T_4}$ ----- (2)

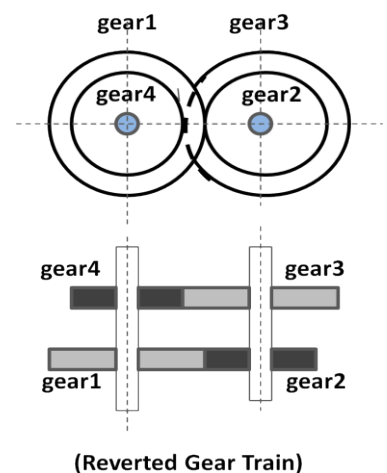

Multiplying equation 1 and 2 we get, $\frac{N_2}{N_1} \times \frac{N_4}{N_3} = \frac{d_1}{d_2} \times \frac{d_3}{d_4} = \frac{T_1}{T_2} \times \frac{T_3}{T_4}$

$$\Rightarrow \frac{N_4}{N_1} = \frac{d_1}{d_2} \times \frac{d_3}{d_4} = \frac{T_1}{T_2} \times \frac{T_3}{T_4} = \frac{\text{Product of the number of teeth on drivers}}{\text{Product of the number of teeth on driven}}$$

Q.27) Explain the working of Epicyclic gear train.

Ans) In epicyclic gear train the axes of some of wheels are not fixed but rotate around the axes of other wheels. Epicyclic means one gear revolving upon and around another. This design can produce large gear ratios in a small space and are used on a wide range of applications from marine gearboxes to electric screwdrivers.

In figure, Gear B meshes with gear C and revolves around it when the arm is rotated. B is called the planet gear and C the sun.

If planet gear rotates around sun gear, then Gear B revolves once on its own axis.

If sun gear rotates around planet gear, then Gear C revolves once on its own axis.

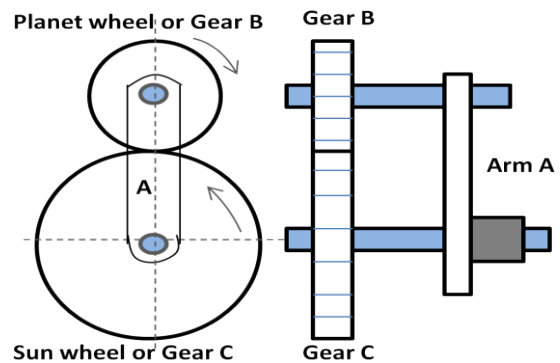

(Epicyclic Gear Train)

Q.28) Define speed ratio, train value and gear ratio.

Ans) Speed ratio: It is the ratio of the speed of the driver to the speed of the driven.

Mathematically, speed ratio or velocity ratio = $\frac{N_1}{N_2} = \frac{T_2}{T_1}$

Train value: It is the ratio of speed of the driven to the speed of the driver.

Mathematically, Train value = $\frac{N_2}{N_1} = \frac{T_1}{T_2}$

Gear ratio: It is the ratio of number of teeth on the gear to the number of teeth on the pinion.

Mathematically, $G = \frac{T}{t}$ where, T = number of teeth on gear and t = number of teeth on pinion

Q.29) State the advantages of V-belt drive over flat belt drive. State its disadvantages.

Ans) The following are the advantages of V-belt drive.

- ♣ Positive drive can be obtained due to no slip and creep.
- ♣ They are suitable for short distance.
- ♣ They are flexible and have no joint problems.
- ♣ Less repairing and maintenance is required.
- ♣ Smoother in operation and less noise.
- ♣ More power can be transmitted due to no slip, creep and higher velocity ratio.
- ♣ High efficiency.

The following are the disadvantages.

- ♣ Construction of V-belt is complicated.
- ♣ They are not suitable for long distances.
- ♣ The v-belts are expensive.
- ♣ Velocity fluctuation is higher.
- ♣ Friction between belt and groove is higher and it leads to wear.

ASSIGNMENT

Group - A: 2 Mark Questions

1. State the expression for velocity ratio in belt drive considering both thickness and slip.
2. Define velocity ratio in belt drive.
3. State the expression for ratio of tension in belt drive.
4. In which type of drive the angle of contact or lap is same for both the pulleys.
5. State the expression for centrifugal tension in belt drive.
6. State the condition for maximum power transmission in belt drive.
7. State the expression for length of belt of an open belt drive.
8. State the expression for length of belt in a crossed belt drive.
9. Define creep and slip in belt.
10. What do you mean by initial tension in belt?
11. Define Simple and Compound gear train.
12. Define Reverted and Epicyclic gear train.
13. Define circular pitch. Diametral pitch and module.
14. Express the relation between circular pitch. Diametral pitch and module.

Group - B: 5 Mark questions

1. Derive the expression for length of belt in a open belt drive.
2. Derive the expression for length of belt in a crossed belt drive.
3. Derive expression for centrifugal tension in belt drive.
4. Derive the expression $\frac{T_1}{T_2} = e^{\mu \theta}$ in a belt drive.
5. Explain the working of reverted and epicyclic gear train.
6. Explain and determine the velocity ratio of Simple gear train.
7. Explain and determine the velocity ratio of Compound gear train.

Group - C: 7 Mark questions

1. Find the power transmitted by a belt running over a pulley of 600 mm diameter at 200 rpm. The coefficient of friction between the belt and the pulley is 0.25, angle of lap 150° and maximum tension in the belt is 2400 N.
2. A leather belt having thickness of 9 mm is required to transmit 12 KW from a motor at 900 rpm. The diameter of driving pulley is 300 rpm. The driven pulley runs at 400 rpm and the centre distance is 3.2 m. Find the width of the belt required for the following data:
 - i) density of leather = 1000 Kg/m^3
 - ii) maximum allowable stress = 2.5 MPa
 - iii) coefficient of friction = 0.3
3. An open belt drive connects two pulleys 120 cm and 50 cm diameters, on parallel shafts 4 m apart. The maximum tension in the belt is 1855.3 N. The coefficient of friction is 0.3. The driver pulley of diameter 120 cm runs at 200 r.p.m calculates:
 - (i) The power transmitted, and
 - (ii) Torque on each of the two shafts.

END of Chapter

GOVERNOR

Q.1) State the function of governor.

Ans) A governor is used to maintain the mean equilibrium speed of an engine, when there is fluctuation of speed of an engine due to variation of load upon the engine.

Q.2) Classify the Governors.

Ans)

Centrifugal governor:

In this type of governor pair of masses known as fly balls rotates with the spindle to produce centrifugal effect for the required action of governor. Examples of these types of governors are: Watt Governor, Porter Governor, Proell governor, Hartnell governor

Inertia governor:

In this type of governor the angular acceleration or deceleration of the spindle along with centrifugal forces acting on the balls is considered. The balls are operated by the rate of change of engine speed.

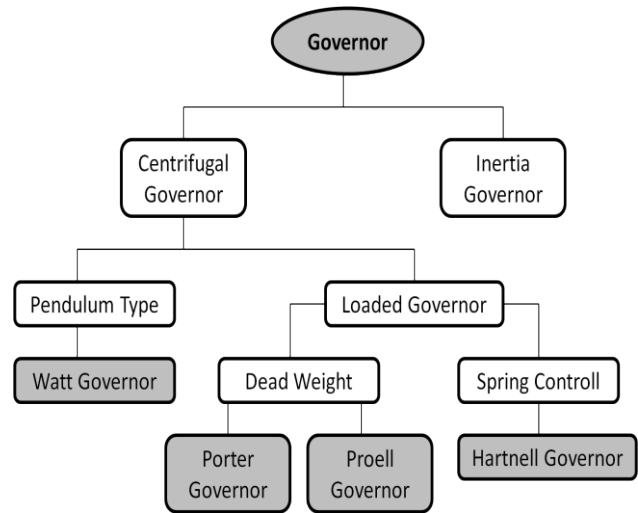

Q.3) Explain the working of Watt governor.

Ans) Working of Watt governor:

It is a simple centrifugal governor. It consists of: (i) pair of balls (fly balls) (ii) spindle (iii) links (iv) sleeve and bell crank lever

The spindle is driven by an engine through bevel gears. A sleeve is attached on to the spindle which slides over it. Fly balls are arranged by a linkage which rotates with the spindle to produce centrifugal action.

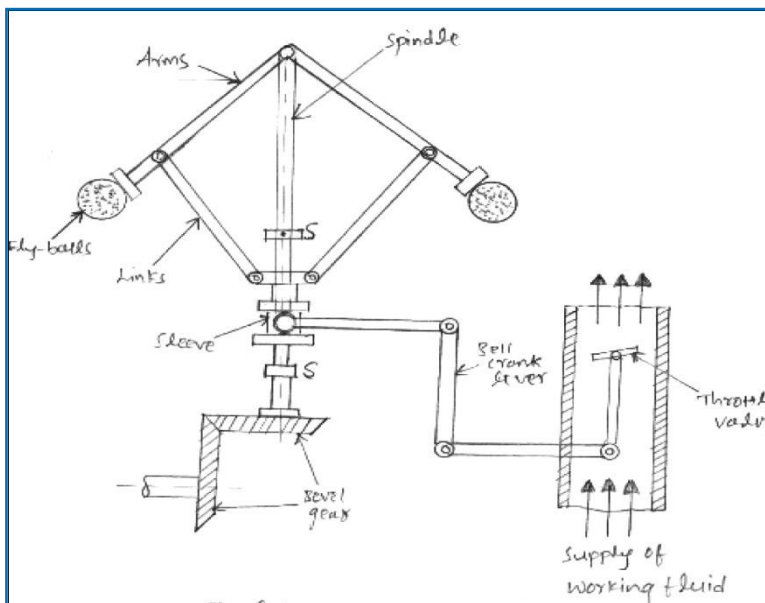

When the load on the engine shaft increases its speed decreases and the spindle of the governor rotates with this speed. The fly balls rotate so close to the axis due to decrease in centrifugal force on the balls. In this way the sleeve moves and this movement operates a linkage to operate the throttle valve for the increase of fuel supply. When the engine shaft rotates with its mean speed the governor comes back to its original position.

When the load on the engine shaft increases its speed decreases and the spindle of the governor rotates with this speed. The fly balls rotate so close to the axis due to decrease in centrifugal force on the balls. In this way the sleeve moves and this movement operates a linkage to operate the throttle valve for the increase of fuel supply. When the engine shaft rotates with its mean speed the governor comes back to its original position.

When the load on the engine shaft decreases its speed increases and the spindle of the governor rotates with this speed. The fly balls rotate away from the axis due to increase in centrifugal force on the balls. In this way the sleeve moves and this movement operates a linkage to operate the throttle valve for the decrease of fuel supply. When the engine shaft rotates with its mean speed the governor comes back to its original position.

Q.4) Explain the working of Porter

governor.Ans) Working of Porter governor:

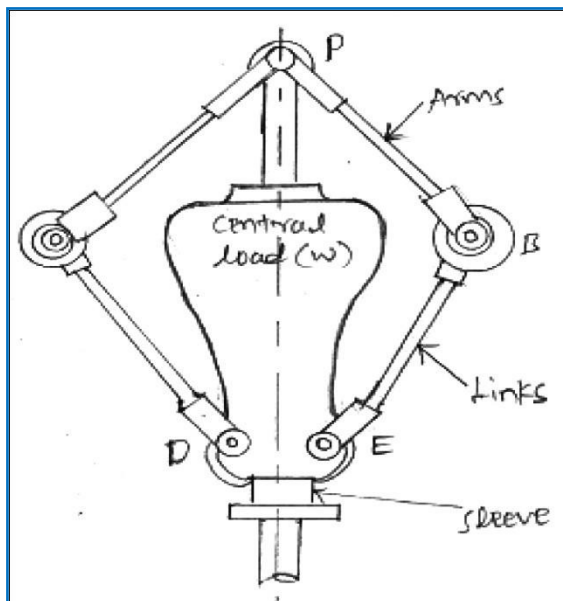

The Porter governor is a modification of a Watt's governor, with central load attached to the sleeve as shown in Figure.

There are two sets of arms. The top arms connect balls to the hinge. The hinge may be on the spindle or slightly away. The lower arms support dead weight and connect balls also. All of them rotate with the spindle.

When the loaded sleeve moves up and down the spindle; the frictional force acts on it in a direction opposite to that of the motion of sleeve. It works in the same principles of Watt governor.

Q.5) Explain the working of Hartnell governor.

Ans) Working of Hartnell governor:

It is a centrifugal type governor where the balls are controlled by spring force. It consists of: (i) Pair of balls, (ii) pair of bell crank levers, (iii) roller, (iv) pair of arms, (v) spindle, (vi) sleeve, (vii) spring and screw cap.

At initial position the spring is in compression and put force on the sleeve. The two bell crank levers are carrying balls at their one end and roller at the other end and are attached with the pair of arms. The arms are attached to the spindle and rotate. The rollers are fitted into the groove of a sleeve and transmit the motion.

When the speed of the engine increases, governor spindle rotates with this speed and causes the balls to move away from the axis of the spindle. The bell crank lever move on to the pivot and lift the sleeve against the spring force. In this way the throttle is operated by the linkage attached with sleeve to decrease the supply of working fuel. When the engine shaft rotates with its mean speed the governor comes back to its original position and the spring also put the force on the governor.

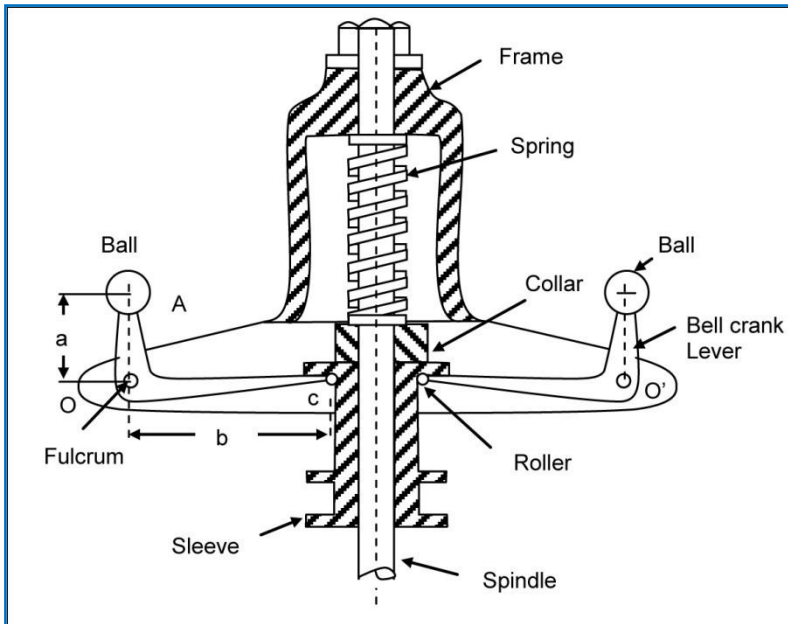

When the speed of the engine decreases, governor spindle rotates with this speed and causes the balls to move nearer to the axis of the spindle. The bell crank lever move and push the sleeve moves downward. In this way the throttle is operated by the linkage attached with sleeve to increase the supply of working fuel. When the engine shaft rotates with its mean speed the governor comes back to its original position and the spring also put the force on the governor.

Q.6) Define sensitivity, stability and isochronism of a governor.

Ans) Sensitiveness of a governor:

It is the ratio of difference between the maximum and the minimum speed to the mean equilibrium speed.

$$\text{Mathematically, Sensitiveness} = \frac{\text{Range of speed}}{\text{Mean speed}} = \frac{N_2 - N_1}{N} = \frac{2(N_2 - N_1)}{N}$$

where, N = mean speed,

N_1 = maximum speed in full load condition and N_2 = minimum speed in no load condition

Stability of a governor:

If the radius of rotation of the balls of a governor doesn't decrease or increase with increase or decrease of speed, then the governor is known as stable. For stability of a governor if the equilibrium speed of engine increases, the radius of governor balls must be increase.

Isochronous governor:

If the equilibrium speed of a governor is constant or range of speed is zero, friction is not considered the governor is known as isochronous governor.

FLYWHEEL

Q.1) State the function of flywheel.

Ans) A flywheel stores the excess energy in an engine and supplies it when there is a requirement of energy. It also controls the fluctuation of speed but does not control the speed variations caused by the varying loads.

Q.2) Distinguish among the governor and flywheel.

Ans)	<u>Flywheel</u>	<u>Governor</u>
	1. Flywheel controls the variation of speed of engine during each revolution of engine shaft.	1. Governor controls the variation of speed of the engine over a number of revolutions.
	2. Variation of speed controlled by flywheel is caused due to fluctuation in turning moment during cycle.	2. Variation of mean speed controlled by governor is caused due to fluctuation in load on engine over a period of time.
	3. It controls the variation of speed by providing stored energy during the cycle.	3. It controls the mean speed of the engine by regulating the fuel supply.
	4. A flywheel has no control over the quantity of charge.	4. A governor takes care of the quantity of working fluid.
	5. It is not an essential element for prime mover.	5. It is an essential element for prime mover.

Q.3) Define the following terms. (i) Maximum fluctuation of energy, (ii) Maximum fluctuation of speed, (iii) Coefficient of fluctuation of speed and (iv) Coefficient of Steadiness.

Ans) Maximum fluctuation of energy: It is the difference between the maximum energy to the minimum energy of the engine.

Mathematically, Maximum fluctuation of energy (ΔE) = Max. Energy – Min. Energy

Maximum fluctuation of speed: It is the difference between the maximum and minimum speed of an engine.

Coefficient of fluctuation of speed: It is the ratio of maximum fluctuation of speed to the mean speed of an engine.

Mathematically, Coefficient of fluctuation of speed (C_s) = $\frac{N_1 - N_2}{N}$

Where, N_1 = maximum speed in r.p.m N_2 = minimum speed in r.p.m
 $N = \frac{N_1 + N_2}{2}$ = mean speed

Coefficient of Steadiness:

It is the reciprocal of coefficient of fluctuation of speed. It is denoted by 'm'.

Mathematically, $m = 1/C_s$

END of Chapter

BALANCING OF MACHINES

Q.1) Define balancing.

Ans) Balancing is the technique of correcting or eliminating unwanted inertia forces or moments in rotating or reciprocating masses and is achieved by changing the location of the mass centers.

Q.2) What do you mean by static and dynamic balancing? Explain.

Ans) Static Balancing:

i) Static balancing is a balance of forces due to action of gravity.

ii) A body is said to be in static balance when its centre of gravity is in the axis of rotation.

Dynamic balancing:

i) Dynamic balance is a balance due to the action of inertia forces.

ii) A body is said to be in dynamic balance when the resultant moments or couples, which involved in the acceleration of different moving parts is equal to zero.

iii) The conditions of dynamic balance are met, the conditions of static balance are also met.

Q.3) What do you mean by balancing of rotating mass?

Ans) When a mass moves along a circular path, centrifugal force acts on the mass in radially outward direction. This is a disturbing force whose direction changes with the rotation of mass. The method of balancing this disturbing forces and setting the masses in correct location to avoid unbalance is known as balancing of rotating masses.

This type of unbalance is common in steam turbine rotors, engine crankshafts, rotors of compressors, centrifugal pumps etc.

Q.4) Explain the concept of Balancing of a single rotating mass by a single mass rotating in the same plane.

Ans)

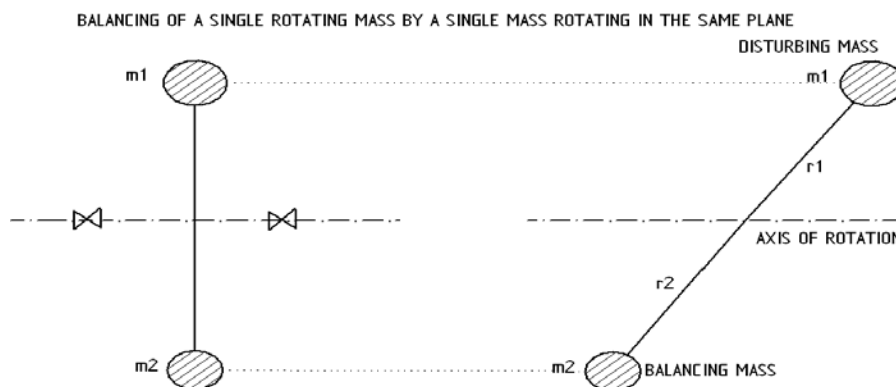

Consider a disturbing mass m_1 which is attached to a shaft rotating at ω rad/s and a balancing mass m_2 which is also attached to the same shaft rotating at ω rad/s.

Let, r_1 = radius of rotation of mass m_1 r_2 = radius of rotation of mass m_2
 Centrifugal force exerted by mass m_1 on the shaft = $F_{c1} = m_1 \omega^2 r_1$ (i)

Centrifugal force exerted by mass m_2 on the shaft = $F_{c2} = m_2 \omega^2 r_2$ (ii)

=

The force F_{c1} of disturbing mass m_1 acts radially outwards and produces bending moment on the shaft. In order to balance its effect, an equal and opposite force F_{c2} is given by using the mass m_2 .

Q.5) Explain the concept of balancing of several masses rotating in the same plane.

Ans)

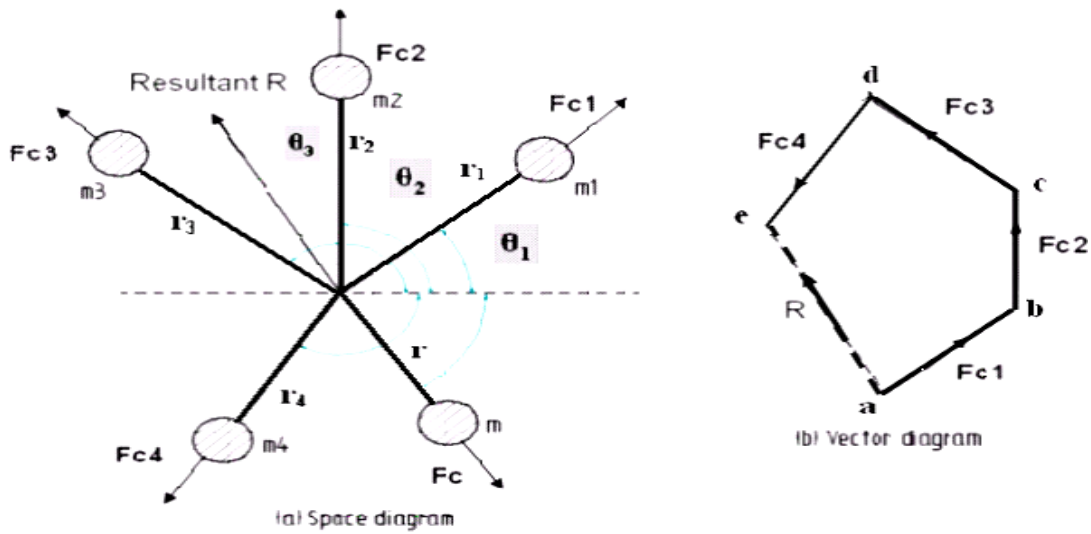

BALANCING OF SEVERAL MASSES ROTATING IN THE SAME PLANE

Consider four masses m_1, m_2, m_3 and m_4 revolving at radii r_1, r_2, r_3 and r_4 respectively in the same plane. These mass exerts centrifugal forces F_{c1}, F_{c2}, F_{c3} and F_{c4} respectively.

Let $F =$ sum of forces F_{c1}, F_{c2}, F_{c3} and F_{c4} .
$$= F_{c1} + F_{c2} + F_{c3} + F_{c4}$$

$$= m_1 r_1 \omega^2 + m_2 r_2 \omega^2 + m_3 r_3 \omega^2 + m_4 r_4 \omega^2 \quad \text{--- (i)}$$

F is the resultant force of these four centrifugal forces.

Consider another mass m revolving at radius r on the same shaft which can balance these four masses. Centrifugal mass exerted by mass $m = F_c = m.r.\omega^2$ _____ (ii)

For balancing, the forces F and F_c must be equal and opposite.

Thus
$$m_1 r_1 \omega^2 + m_2 r_2 \omega^2 + m_3 r_3 \omega^2 + m_4 r_4 \omega^2 = m.r.\omega^2$$

$$\Rightarrow m_1 r_1 + m_2 r_2 + m_3 r_3 + m_4 r_4 = m.r$$

Q.6) Explain the concept of balancing of reciprocating masses.

Ans) Consider the following figure to study the balancing of reciprocating masses.

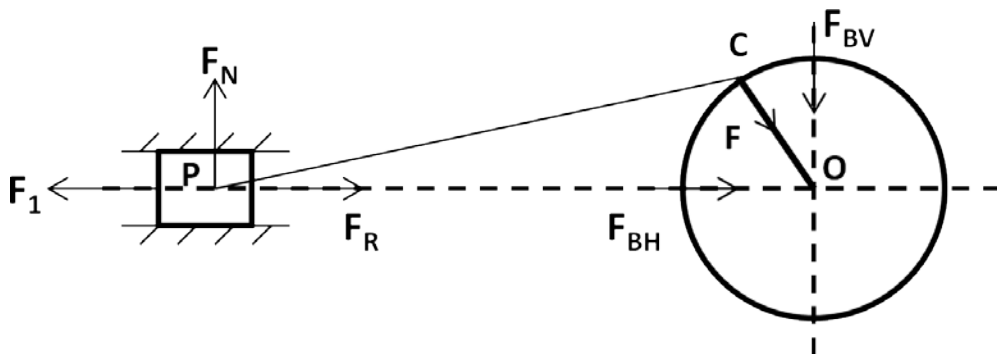

$F_R =$ Force required to accelerate the reciprocating mass

$F_I =$ Inertia force due to reciprocating mass

$F_N =$ Force on the sides of the cylinder walls

$F_B =$ Force acting on the crank shaft bearing or main bearing

Angle COP = Θ

- ♣ F_R and F_I are equal in magnitude and opposite in direction, so they will cancel to each other.
- ♣ The horizontal component F_{BH} is equal to F_I and opposite in direction. This force is unbalanced force which required proper balancing.
- ♣ The force on the sides of the cylinder wall and vertical component F_{BV} are equal and opposite but forms a shaking couple.
- ♣ The shaking couple or shaking force varies in magnitude and direction, so they cause vibration.
- ♣ In the reciprocating masses by adding balancing masses, it is not practically to eliminate them completely. In other words the reciprocating masses are partially balanced.

Q.7) What are the causes and effects of unbalance?

Ans) Causes of unbalance:

- ♣ Slight variation in the density of the material
- ♣ Inaccuracies in the casting
- ♣ Inaccuracies in machining of the parts
- ♣ Misalignment of parts

Effects of unbalance:

- ♣ Unbalance of machine parts causes vibration.
- ♣ Unbalance masses produce disturbing forces which causes non equilibrium of forces.
- ♣ Unbalance forces may cause bending of parts and failure of machine parts.

END of Chapter

VIBRATION

Q.1) Define the following terms: (i) time period (ii) amplitude (iii) cycle (iv) frequency.

Ans) Time Period: It is the time taken to complete one cycle. It is the time period after which the motion of a vibratory body repeats itself. It is denoted by **T**. Its unit is second.

Amplitude: It is the maximum displacement of oscillating body from its mean equilibrium position.

Cycle: It is the motion completed during one time period.

Frequency: It is the number of cycles per unit time. It is given by Hertz (Hz)

Q.2) State the relation between time period and frequency.

Ans) Frequency is the reciprocal of time period. i.e
$$\text{Frequency} = \frac{1}{\text{Time period}}$$

Q.3) Define the following terms: (i) free vibration (ii) forced vibration (iii) damped vibration.

Ans) Free/Natural vibration: When no external force act on the body after giving an initial displacement to the body, then the body is said to be in free or natural vibration.

Forced vibration: When the body vibrates under the action of an external force, then the body is said to be in forced vibration.

Damped vibration: When there is reduction in amplitude over every cycle of vibration, it is called damped vibration.

Q.4) Define the following terms: (i) longitudinal vibration (ii) transverse vibration (iii) torsional vibration.

Ans) Longitudinal vibration: When the particles of the shaft or disc moves parallel to the axis of the shaft or disc, then the vibration produced is called longitudinal vibration.

Transverse vibration: When the particles of the shaft or disc moves approximately perpendicular the axis of the shaft or disc, then the vibration produced is called transverse vibration.

Torsional vibration: When the particles of the shaft or disc moves in a cycle about the axis of the shaft or disc, then the vibration produced is called Torsional vibration.

Q.5) State the causes and remedies of vibration.

Ans)	<u>Causes</u>	<u>Remedies</u>
Lack of balance	In a machine there may be a number of rotating and reciprocating parts having the motion in different planes, causes dynamic forces. If all the dynamic forces are not balanced, as a result vibration produced in machine.	<i>The machine parts must be kept under static and dynamic balancing.</i>
Loose fitting	If the machine parts are not properly fitted such as the nuts, screws, bolts are not perfectly tightened; as a result vibration develops in machine.	<i>The machine parts must be tight fitted properly.</i>
Incorrect alignment	In a machine there may be one or more places where power transmission takes place. If the driver and driven parts are not properly aligned, as a result vibration produced in machine.	<i>The alignment test must be performed to check the alignment of the machine parts.</i>

Vibration wave If the heavy machines are operated nearer to each other, then the sound produced by the working machines causes vibration.

The heavy machines must be installing at distance places to minimize the effect of vibration sound waves.

Lack of isolation If the isolation is not provided between the machine and the foundation, then the vibration are transmitted to another machines.

The isolation of machine in foundation must be done carefully to make a rigid installation for minimizing effect of vibration.

Lack of compact soil If the soil of the machine foundation is wet, loose or not compact then the settlement of the machine remains incorrect. It causes vibration.

The condition of soil must be checked and corrected before installation of machine parts.

Q.6) Write a short note on (i) longitudinal vibration (ii) transverse vibration (iii) torsional vibration.

Ans) Longitudinal vibration –

When the particles of the shaft or disc moves parallel to the axis of the shaft or disc, then the vibration produced is called longitudinal vibration. In this case the shaft elongates and shortens alternately. In figure three position of disc is shown.

$$\text{Time period (T)} = \frac{2\pi}{w} = 2\pi \times \sqrt{\frac{m}{s}}$$

The frequency in the longitudinal vibration is given by the relation,

$$f_n = \frac{1}{2\pi} \times \sqrt{\frac{s}{m}}$$

where, f_n = Natural frequency,
 s = Stiffness of the spring,
 m = Mass of the spring.

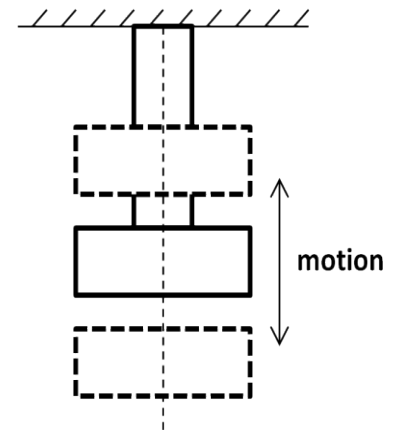

(Longitudinal vibration)

Transverse vibration:

When the particles of the shaft or disc moves approximately perpendicular the axis of the shaft or disc, then the vibration produced is called transverse vibration. In this case the shaft bends or straights alternatively. Bending stresses are induced in the shafts.

$$\text{Time period (T)} = \frac{2\pi}{w} = 2\pi \times \sqrt{\frac{m}{s}}$$

The frequency in the longitudinal vibration is given by the relation,

$$f_n = \frac{1}{2\pi} \times \sqrt{\frac{s}{m}}$$

where, f_n = Natural frequency
 s = Stiffness of the spring
 m = Mass of the spring.

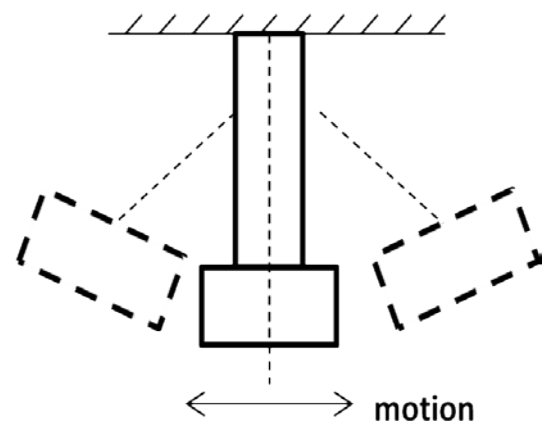

(Transverse vibration)

Torsional vibration:

When the particles of the shaft or disc moves in a cycle about the axis of the shaft or disc, then the vibration produced is called Torsional vibration. In this case the shaft twisted or untwisted alternatively. Torsional shear stresses are induced in the shafts.

The frequency in the longitudinal vibration is given by the relation, $f_n = \frac{1}{2\pi} \times \sqrt{q/I}$

where, f_n = Natural frequency

q = Torsional stiffness of the spring

I = Mass moment of inertia of the disc.

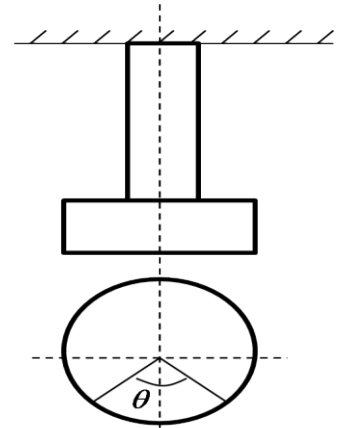

Twist of disc

(Torsional vibration)

END of Chapter