

C.V. RAMAN POLYTECHNIC

BHUBANESWAR



LAB MANUAL

Year & Semester: 3RD Year, V Semester

Subject Code: PR-1

Subject Name: ELECTRICAL MACHINE LAB-II

**DEPARTMENT
OF
ELECTRICAL ENGINEERING**

VISION OF DEPARTMENT

To develop technically skilled Electrical Engineers contributing to sustainable development and technological advancement.

MISSION OF DEPARTMENT

- To implement an effective teaching-learning process to develop skilled electrical engineers
- To provide technical and entrepreneurial skills to students and make them ready to be Placed in industry.
- Encouraging the students to pursue higher education and career-oriented courses.
- Developing ethics in students as well as responsibility towards the environment and The society

PROGRAM OUTCOMES (PO)

PO1	Basic and discipline-specific knowledge
PO2	Problem analysis
PO3	Design/development of solutions
PO4	Engineering tools, experimentation, and testing
PO5	Engineering Practices for society, sustainability, and environment
PO6	Project Management
PO7	Lifelong Learning

COURSE OBJECTIVE AND COURSE OUTCOMES

PRACTICAL COURSE OBJECTIVE

- To Familiarize Students with Motor Starting Techniques.
- To Develop Skills in Motor Control and Direction Reversal.
- To Teach Performance Testing of Electrical Machines.
- To Enhance Understanding of Power Measurement and Energy Metering.
- To Introduce Protective Devices and Their Applications.

PRACTICAL COURSE OUTCOMES (CO)

Course Name	Statements
CO1	Understand and Demonstrate Starting Methods for 3-Phase Induction Motors
CO2	Perform Direction Control of Induction Motors
CO3	Conduct Performance Tests on Electrical Machines
CO4	Analyze Power Measurement and Energy Metering in 3-Phase Systems
CO5	Evaluate Protective Relays and Circuit Breakers

MAPPING OF LABORATORY EXPERIMENTS OF ELECTRICAL MACHINE LAB-II TO DEFINED CO

SL NO	EXPERIMENT NO	COURSE OUTCOME
1	1,2	C01
2	3,4	C02
3	5,6,7,8	C03
4	9,10	C04
5	11,12,13,14	C05

MATRIX OF COs AND POs

Course Outcomes	Expected Mapping of COs with Programme Outcomes (POs) (1- Weak Correlation; 2- Medium correlation; 3- Strong Correlation)							Average CO
	PO1	PO2	PO3	PO4	PO5	PO6	PO7	
C01	3.0	2.0	1.0	2.0	1.0	-	2.0	1.8
C02	3.0	3.0	2.0	2.0	-	-	2.0	2.4
C03	3.0	3.0	2.0	3.0	-	-	2.0	2.6
C04	3.0	3.0	2.0	3.0	-	-	2.0	2.6
C05	3.0	3.0	2.0	2.0	2.0	1.0	2.0	2.1
Average PO	3.0	2.8	1.8	2.4	1.5	1.0	2.0	2.4 2.1

Program Specific Outcomes (PSOs):

PSO1: Ability to apply electrical engineering knowledge, skills for testing, control & maintenance of electrical systems such as Machines, Power Systems, Drives & Automation.

PSO2: Ability to identify problems in the diversified areas of Electrical Engineering and determine the hardware or software solutions to support the Societal, Environmental & Industrial needs.

MATRIX OF COs AND PSOs

CO/PSO	PSO1	PSO2	Average CO
CO1	3.0	2.0	2.5
CO2	3.0	3.0	3
CO3	3.0	3.0	3
CO4	3.0	3.0	3
CO5	3.0	3.0	3
Average PSO	3.0	2.8	

LIST OF EXPERIMENTS

SL. NO.	NAME OF THE EXPERIMENT	PAGE NO.
1	Study of Direct on line starter, Star- Delta Starter, connection and running a 3-phase induction motor and measurement of starting current.	3 – 9
2	Study of Auto transformer starter, Rotor resistance Starter, connection and running a 3-phase induction motor and measurement of starting current.	10 – 14
3	Study and Practice of connection & Reverse the direction of rotation of Three Phase Induction motor.	15 – 17
4	Study and Practice of connection & Reverse the direction of rotation of Single Phase Induction motor.	18 – 19
5	Heat run test of 3-phase transformer.	20 – 21
6	OC and SC test of alternator and determination of regulation by synchronous impedance method.	22 – 27
7	Determine of regulation of alternator by direct loading.	28 – 31
8	Parallel operation of two alternators and study load sharing.	32 – 35
9	Measurement of power of a 3-phase Load using two wattmeter method and verification of the result using one 3- phase wattmeter.	36 – 39
10	Connection of 3-phase energy meter to a 3-phase load.	40 – 42
11	Study of an O.C.B.	43 – 45
12	Study of an induction type over current/ reverse power relay.	46 – 47
13	Study of Buchholz's Relay.	48 – 50
14	Study of an Earth Fault Relay.	51 – 52

Experiment - 01

Aim- Study of (manual and Semi-automatic) Direct on line starter, Star-Delta Starter, connection and running a 3-phase induction motor and measurement of starting current.

APPARATUS REQUIRED: -

Sl. No	Name of the Equipment	Specification	Quantity
1	3- ϕ Induction Motor	440v, 1500 RPM, 3HP	1no
2	Insulated Combination Pliers	150mm	1no
3	Screw driver	200mm	1no
4	Line Tester	1100v, 6"	1no
5	3- ϕ DOL Starter	440V, 16A	1no
6	Star-Delta Starter(Manual)	440v,16A	1no
7	Star-Delta Starter(Semi automatic)	440v,16A	1no
8	Multimeter	-	1 no
9	Wires	2.5 sq mm	As per required

Theory:-

3- ϕ Induction Motor:-

The three-phase AC induction motor is a rotating electric machine that is designed to operate on a three-phase supply. This 3 phase motor is also called as an asynchronous motor. These AC motors are of two types: squirrel and slip-ring type induction motors.

It works on the same principle as a DC motor, that is, the current-carrying conductors kept in a magnetic field will tend to create a force.

Direct on line (DOL) starter:-

DOL Starter (Direct Online Starter) is also known as "across the line starter". DOL starter is a device consists of main contactor, protective devices and overload relay which is used for motor starting operations. It is used for low rating usually below 5HP motors.

In direct online starter method of motor starting, the motor stator windings is directly connected to the main supply where the DOL protect the motor circuit from high inrush current which may damage the overall circuit as the initial current is much more higher than the full rated current.

Construction of DOL Starter:-

A DOL or Direct Online starter has simply two buttons; Green and Red, where the green button is used for starting and the red is used for stopping the motor. The green button connects the terminals and closes the circuit while the red button disconnects the terminals and breaks the circuit.

The DOL starter is made of a circuit breaker or MCCB or fuse, an overload relay and contactor or coil. The circuit breaker is used for protection against short circuits while the overload relay protects the motor from overloading. The contactor is used for starting and stopping the motor where the green and red buttons are connected.

DOL Starter Working Principle:-

The working principle of a DOL starter begins with the connection to the 3-phase main with the motor. The control circuit is connected to any two phases and energized from them only. When we press the start button, the current flows through contactor coil (magnetizing coil) and control circuit also. The current energizes the contactor coil and leads to close the contacts, and hence 3-phase supply becomes available to the motor.

If we press the stop button, the current through the contact becomes discontinued, hence supply to the motor will not be available, and the similar thing will happen when the overload relay operates. Since the supply of motor breaks, the machine will come to rest. The contactor coil (Magnetizing Coil) gets supply even though we release start button because when we release start button, it will get supply from the primary contacts as illustrated in the diagram of the Direct Online Starter.

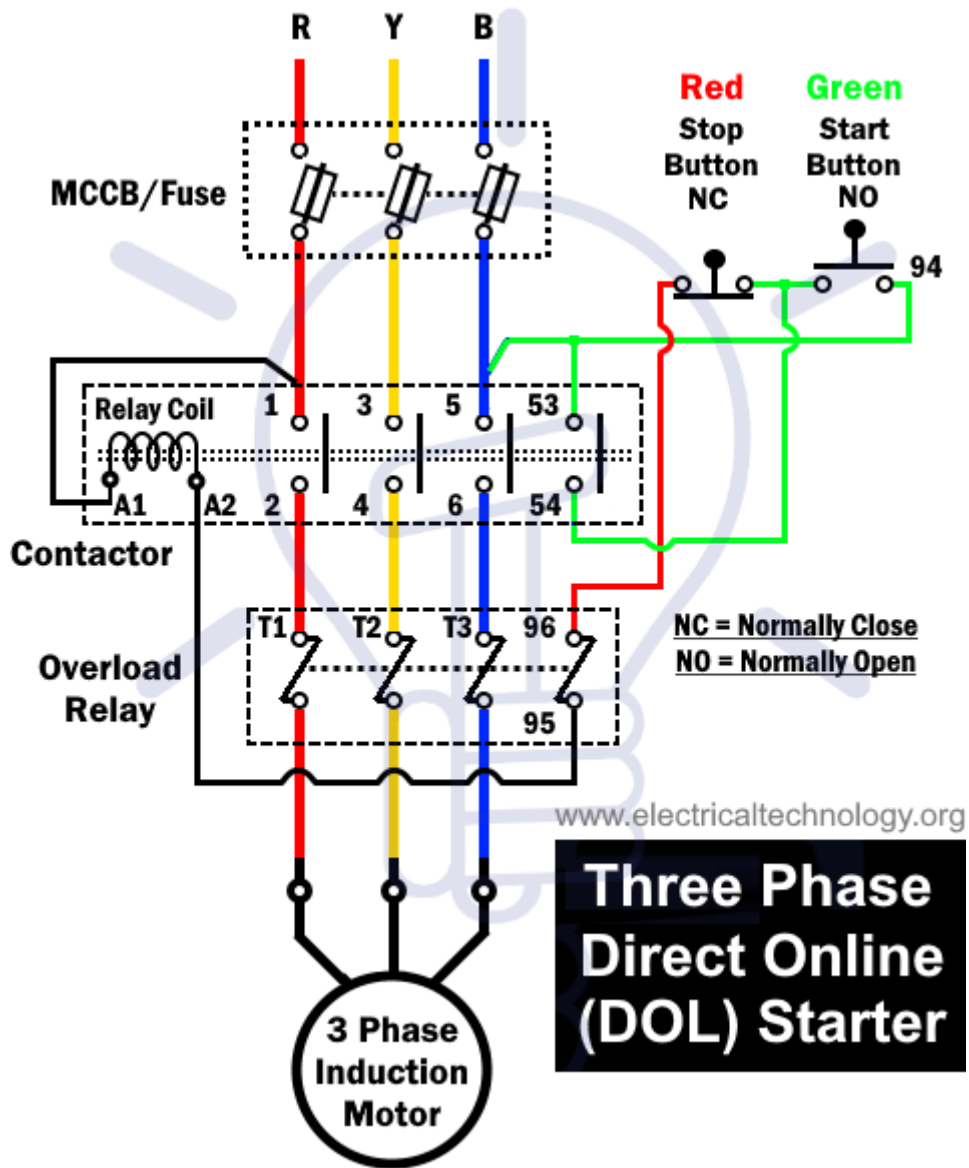

www.electricaltechnology.org

Three Phase Direct Online (DOL) Starter

Star- Delta Starter:-

A star delta starter is the most commonly used method for the starting of a 3 phase induction motor. In star delta starting an induction motor is connected in through a star connection throughout the starting period. Then once the motor reaches the required speed, the motor is connected in through a delta connection

A star delta starter will start a motor with a star connected stator winding. When motor reaches about 80% of its full load speed, it will begin to run in a delta connected stator winding.

A star delta starter is a type of reduced voltage starter. We use it to reduce the starting current of the motor without using any external device or apparatus. This is a big advantage of a star delta starter, as it typically has around 1/3 of the inrush current compared to a DOL starter.

Manual Star-Delta Starter:-

The switch in this starter has three positions: 0 (for OFF), 1 (for Star) and 2 (for Delta). If the switch is placed in 0 – position, the windings of the motor are open and the motor is OFF. To activate the Star Connection, the switch is moved to 1 – position.

During this position of the switch, the finishing ends of the windings i.e. X2, Y2 and Z2 are shorted. This completes the star connection and the motor starts rotating.

As the motor accelerates, it gains speed and as the speed of the motor approaches its rated speed, the switch is moved from 1 – position to 2 – position.

The 2 – position of the switch activates the Delta Connection as it establishes X2-Y1, Y2-Z1 and Z2-X1 contacts. The motor now runs in Delta Connection and reaches its rated speed without any problem.

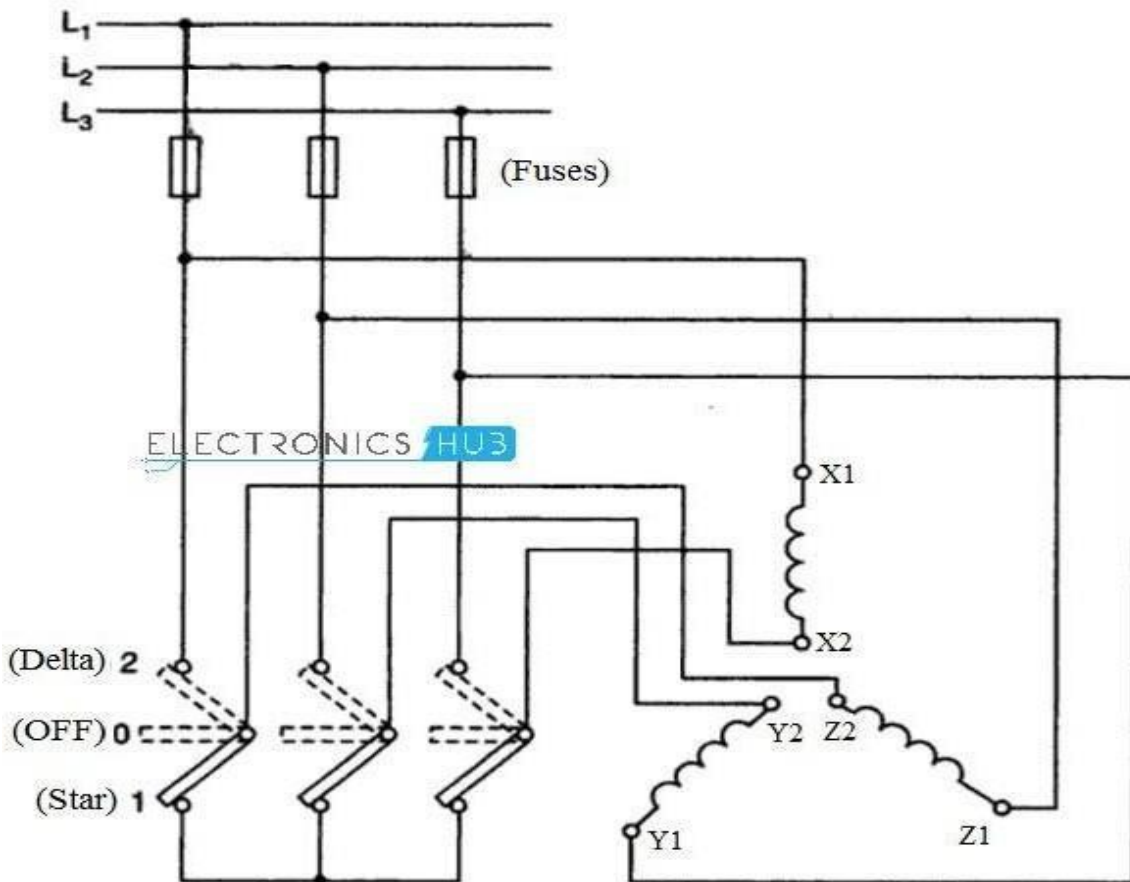

Semi automatic Star-Delta Starter:-

In a Semi – Automatic Star Delta Starter, we require three contactors for connecting the motor windings in Star and Delta Connections. The wiring diagram of the Semi – Automatic Star Delta starter is shown in the following image along with the winding diagram of Delta Connection.

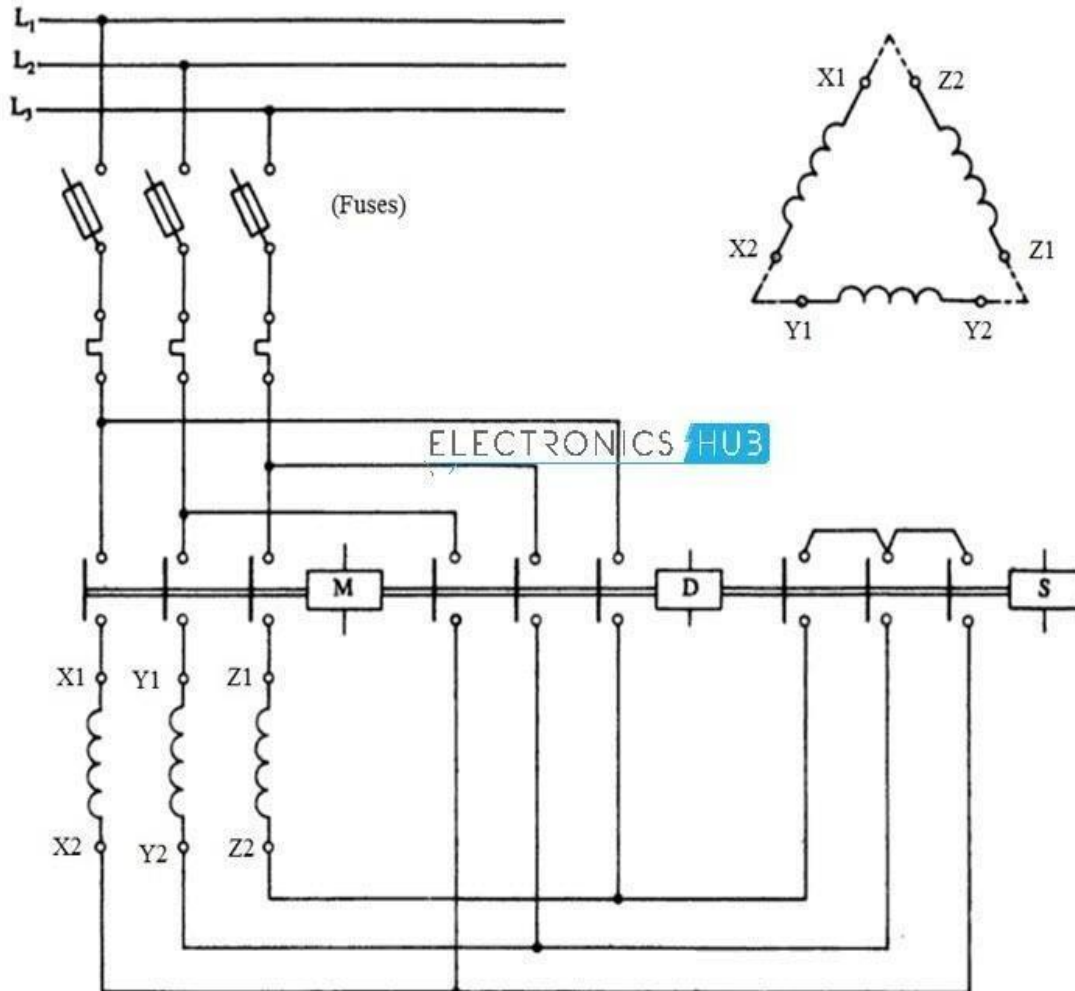

First, the contactor S (for Star Connection) will be used to connect the windings in Star Connection. Now, by closing the main contactor M , we can start the motor in star connection as $X2, Y2$ and $Z2$ are shorted.

After the motor gains speed, the contactor S is opened and contactor D (for Delta Connection) is closed so that the windings are configured in Delta Connection as the motor windings $X2, Y2$ and $Z2$ are connected to $Y1, Z1$ and $X1$ respectively.

It is important open the Star Connection (contactor S) before engaging the Delta Connection if not, short circuit takes place. The following image shows the control circuit of the Semi – Automatic Star Delta Starter.

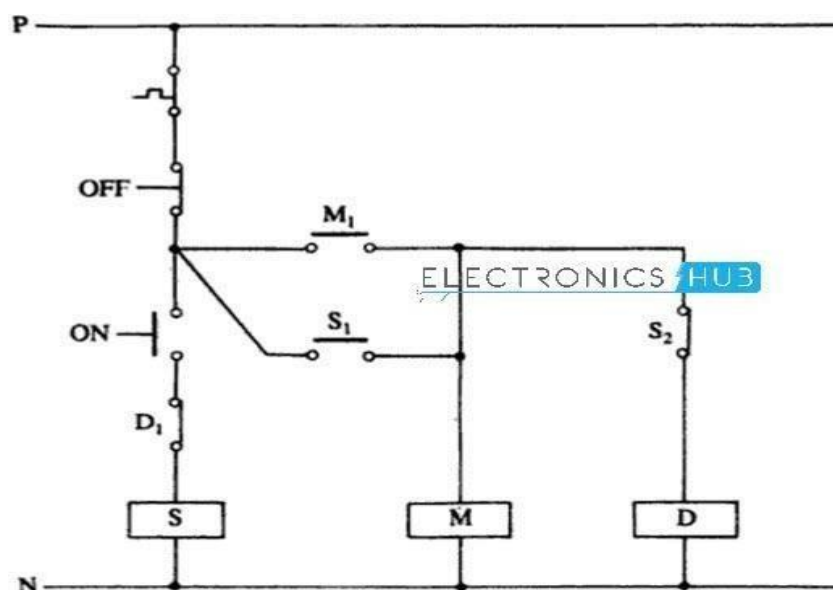

First, when we push the ON button, the contactor S is energized and as a result the motor windings are connected in star connection. The supplementary contacts of S i.e. S1 and S2 gets closed and opened respectively.

Since S1 is closed, the main contactor M gets energized and the motor starts in star connection. After this, the contactor M stays energized by the supplementary contact M1.

Since S2 is open, the Delta Connection cannot be started when Star Connection is activated and in order to activate the Delta Connection, we must disengage the Star Connection.

When the ON button is released, the contact S1 is open and S2 is close as the contactor S is de – energized. As S2 is closed and M is already energized by M1, the motor now runs in Delta Connection.

To turn off the motor, the OFF button is pushed, which will de – energize the contactors M and D (main and delta).

Procedure:-

- * Make the connections as shown in the circuit diagram.
- * Set the timer at the marked position (10 secs).
- * Check the three phase supply at the voltmeter.
- * check the sequence of the operations of the contactors after switching the start button.
- * Connect the power supply terminals R Y B to the M C and delta power terminals RYB on the board.
- * Record the no-load current at starting with the help of ammeter.

Tabulation:-

Sl.No	Name of Starters	Starting Current in Amp
1		
2		
3		

Conclusion:- From the above experiment, we learnt about the, manual and Semi automatic Direct on line starter, Star- Delta Starter, connection and running a 3-phase induction motor and its starting current.

Experiment - 02

Aim- Study of (manual and Semi automatic) Auto transformer starter, Rotor resistance Starter, connection and running a 3-phase induction motor and measurement of starting current.

APPARATUS REQUIRED:-

Sl. No	Name of the Equipment	Specification	Quantity
1	3- ϕ Induction Motor	440v, 1500 RPM, 3HP	1no
2	3- ϕ Slip-ring Induction Motor	440v, 1500 RPM, 3HP	1no
3	Insulated Combination Pliers	150mm	1no
4	Screw driver	200mm	1no
5	Line Tester	1100v, 6"	1no
6	Wire Stripper	150mm	1 no
7	3- ϕ Auto Transformer Starter	440V, 16A	1no
8	Rotor Resistance Starter	440v, 16A	1no
9	Multimeter	-	1no
10	Wires	2.5 sq mm	As per required

Theory:-

3- ϕ Induction Motor:-

The three-phase AC induction motor is a rotating electric machine that is designed to operate on a three-phase supply. This 3 phase motor is also called as an asynchronous motor. These AC motors are of two types: squirrel and slip-ring type induction motors.

It works on the same principle as a DC motor, that is, the current-carrying conductors kept in a magnetic field will tend to create a force.

Auto Transformer Starter:-

Squirrel cage induction motor started on full line voltage using D O L starter as a starting method draw very large starting current which can damage motor winding and also create a current surge on the power system. Hence another starting method is used to start three phase induction motor called an autotransformer starter. Auto transformer Starter can be used for

both star/delta connected induction motors.

The starting current 6 to 8 times the rated current and this can cause voltage dip in supply and also motor and motor-driven equipment experience large torque surge which can damage the motor as well as connected equipment. Three phase autotransformer is used to reduce high inrush starting current.

Many reduce voltage starting methods are used to start induction motor. one of them is autotransformer starter, autotransformer starter is also reduced voltage starter particularly used for higher rating motors greater than 10HP.

Auto-transformer starter (Variable Autotransformer) can be used with any squirrel cage induction motor, motor supplied through taps of three-phase auto transformer starter. In Auto-transformer Starter, Motor is directly connected on secondary of autotransformer.

The taps provided on auto-transformer limit the starting voltage and supply motor in steps of 50% 65% or 80% of nominal voltage. Using auto transformer for starting purpose the line current is always less than motor nominal current during start, because of motor connected to the secondary side of auto-transformer starter during acceleration.

If motor connected to 50% tap of auto transformer, the motor current would be reduced up to 50% of nominal starting current. But the line current will be only 25% of nominal starting current. The difference between line current and motor current due to auto transformer is in the circuit.

Due to the lower line, current auto transformer starter is a very popular type of reduce voltage starter. Since the motor starting current is greater than the line current with autotransformer starter, the starter produced more torque per ampere of line current than any other type of reduce voltage starter

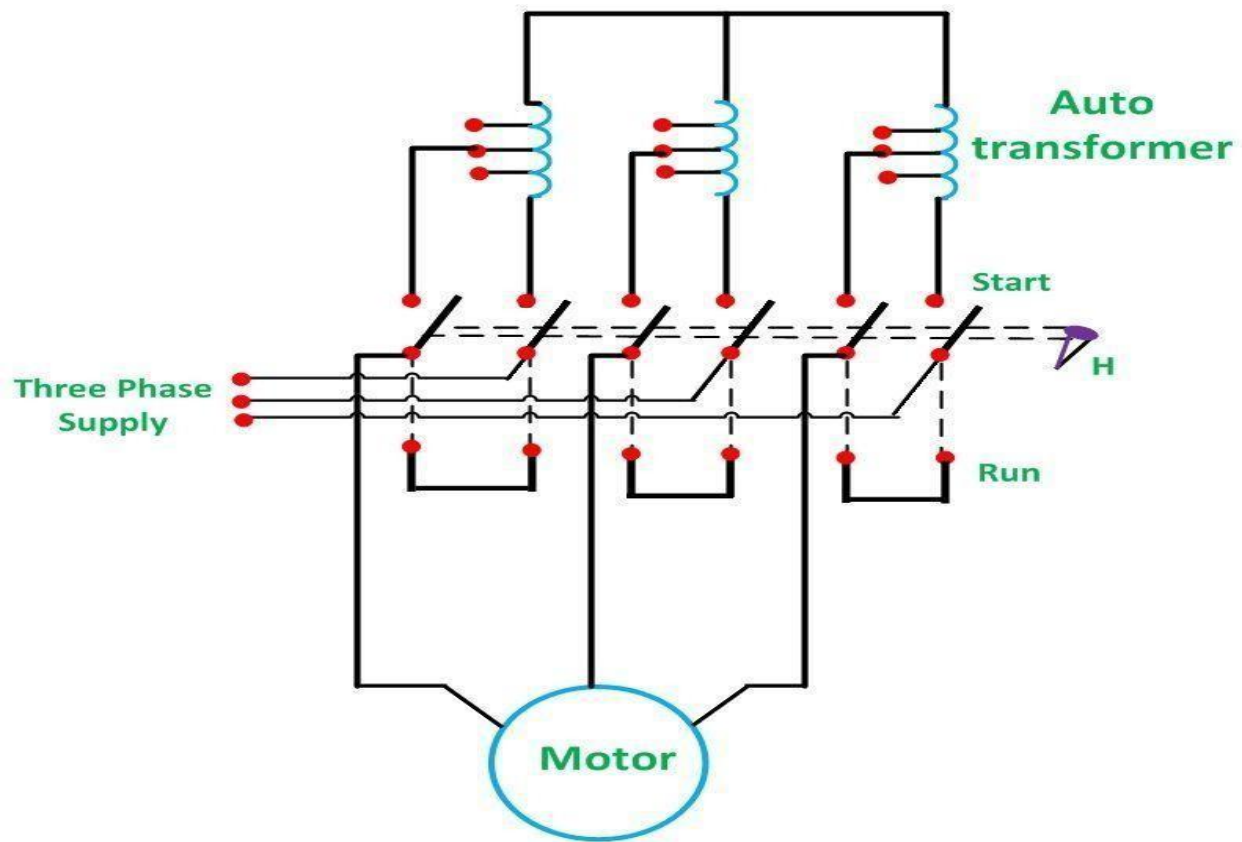

Circuit Globe

Slip-ring Induction Motor:-

A slip ring induction motor is referred to as an asynchronous motor as the speed at which it operates is not equal to the synchronous speed of a rotor. The rotor of this type of motor is wound type. It comprises of a cylindrical laminated steel core and a semi-closed groove at the outer boundary to accommodate a 3-phase insulated winding circuit.

Rotor Resistance Starter:-

These motors are practically started with full line voltage applied across the stator terminals. Starting current is adjusted by introducing a variable resistance or rheostat in the rotor circuit. The rheostat connected in star & the resistance being gradually cut out of the rotor circuit equally in each phase as motor picks up the speed. By increasing the rotor resistance, the rotor current is reduced at starting and the starting torque is also increased due to improvement in power factor.

The controlling rheostat is either contact type as in this experiment or that of the stud type. Starter usually having a line switching contactor for the stator along with no voltage and order current protective device. There is some kind of interlocking to ensure sequential operation of the line contactor and the starter. This interlocking prevents the closing of stator contactor unless the starter is all in. The additional external resistance in the rotor circuit enables a slip ring motor to develop a high starting torque with moderate starting current. Additional resistance cuts as the motor gains speed

Fig 1

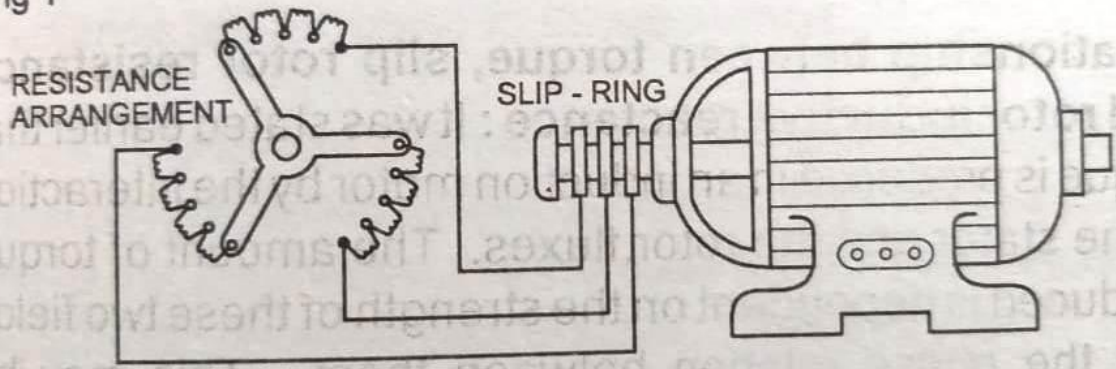

SLIP RING INDUCTION MOTOR WITH RESISTANCE STARTER

EL2A1421

Fig 2

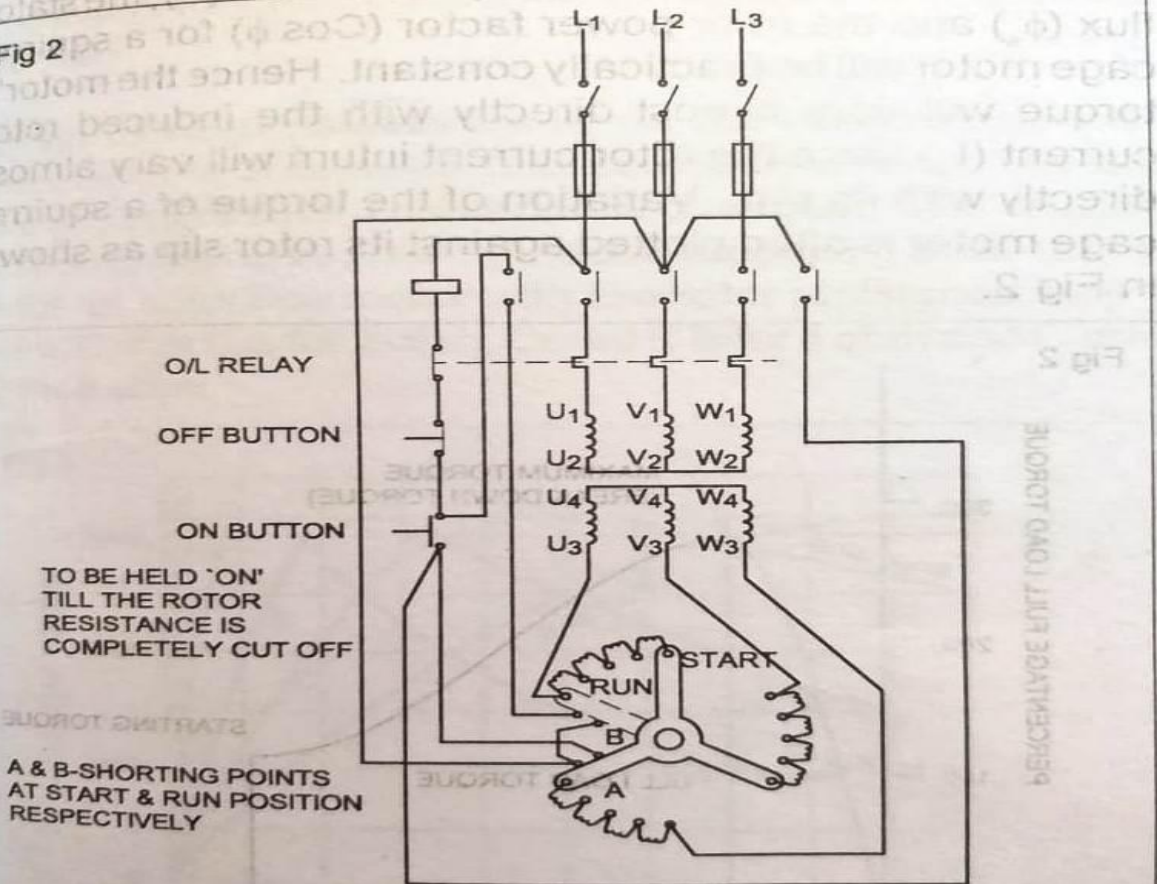

ROTOR RESISTANCE STARTER FOR SLIP RING INDUCTION MOTOR

EL2A1422

Procedure:-

- * Make the connections as shown in the circuit diagram.
- * Set the timer at the marked position (10 secs).
- * Check the three phase supply at the voltmeter.
- * check the sequence of the operations of the contactors after switching the start button.
- * Connect the power supply terminals R Y B to the M C and delta power terminals RYB on the board.
- * Record the no-load current at starting with the help of ammeter.

Tabulation:-

Sl.No	Name of Starters	Starting Current in Amp
1		
2		
3		

Conclusion:- From the above experiment, we learnt about the, Auto Transformer Starter, Rotor resistance Starter, connection and running a 3-phase induction motor and its starting current.

Experiment - 03

Aim- Study and Practice of connection & Reverse the direction of rotation of Three Phase Induction motor.

APPARATUS REQUIRED:-

Sl. No	Name of the Equipment	Specification	Quantity
1	3- ϕ Induction Motor	440v, 1500 RPM, 3HP	1no
2	Insulated Combination Pliers	150mm	1no
3	Screw driver	200mm	1no
4	Line Tester	1100v, 6"	1no
5	Wire Stripper	150mm	1 no
6	D O L Starter	440V, 16A	1no
7	Wires	2.5 sq mm	As per required

Theory:-

The direction of rotation of an electric motor can be changed anytime and easily at the motor terminals. In three-phase motors, the windings configuration can easily be changed from a star or Y connection to a delta or mesh connection at the motor terminal box.

The rotation of a WYE- or delta-connected motor can be changed by exchanging any two of the three phases of the incoming voltage. Fig. 1 shows diagrams for a WYE-connected motor and Fig. 2 shows the diagrams for a delta-connected motor for clockwise (forward) and counterclockwise (reverse) rotation. From these diagrams notice that T1 and T2 supply voltage terminals have been exchanged in the diagram for motor reversal. In industrial applications, terminals T_i and T₂ are generally switched by the contacts of the reversing motor starter. These diagrams will be useful for installation connections and troubleshooting.

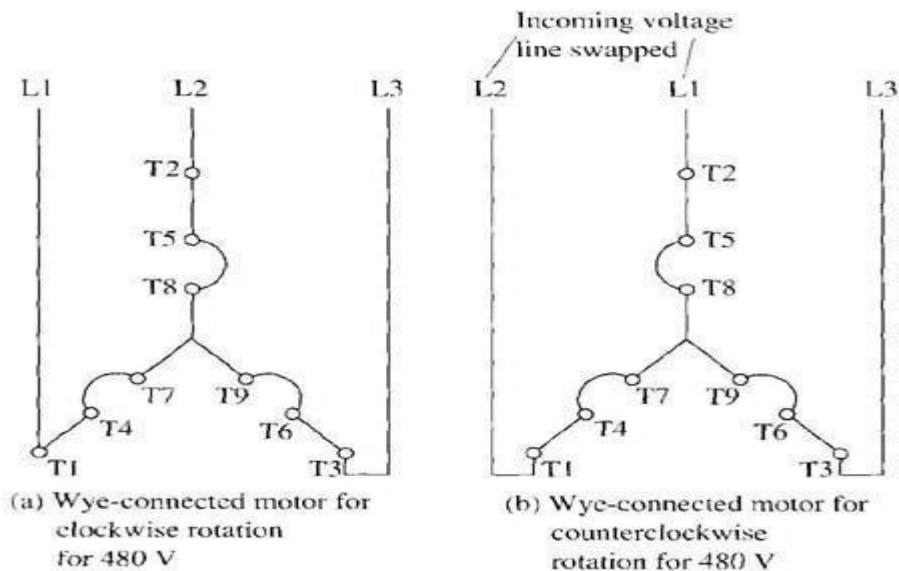

Above: Fig. 1 Diagram of the WYE-connected motor for clockwise and counterclockwise operation. (a) WYE-connected motor for clockwise rotation for 480 V; (b) WYE-connected motor for counterclockwise rotation for 480 V.

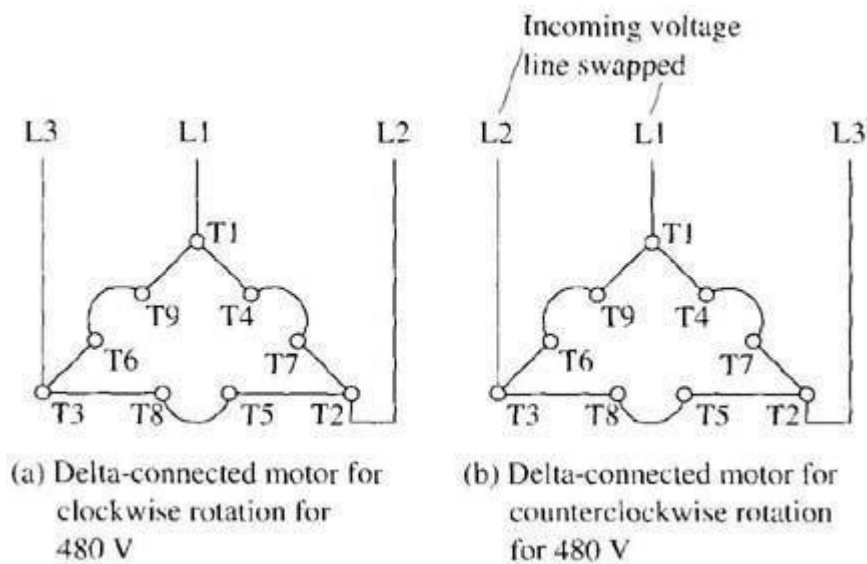

Above: Fig. 2 Diagram of a delta-connected motor for clockwise and counterclockwise operation. (a) Delta-connected motor for clockwise rotation for 480 V (b) Delta-connected motor for counterclockwise rotation for 480 V.

This wiring configuration is also used when the motor is connected for plugging use. When the motor is used for plugging, it's reversed while running at full rpm. When the motor's stator is quickly reconnected for reverse rotation by switching two of the three input voltage lines, it will quickly build up a reverse magnetic field that will begin to rotate in the opposite direction. The rotor will follow this quick change in rotation and begin to rotate in the opposite direction.

This will cause the load to decrease its rpm from full in the clockwise direction to zero, and begin to rotate counterclockwise. The moment the rotor begins to rotate in the opposite direction, the power is de-energized and the rotor shaft is stopped from rapid reverse torque.

ForWard Direction Three Phase IM

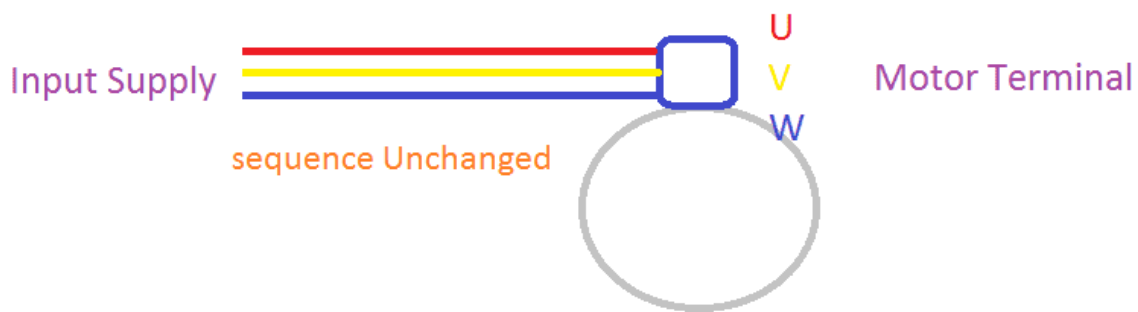

Reverse Direction Three phase IM

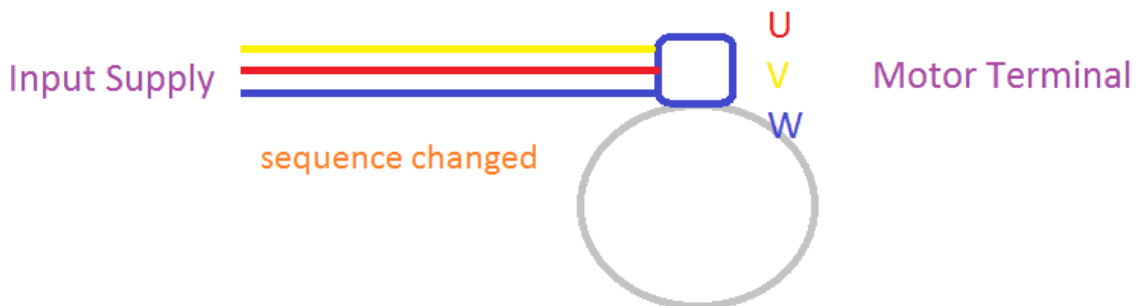

Procedure:-

1. Make sure that all the connection should be as per circuit diagram.
2. The main switch should be at off position before doing the connections.
3. Before changing the connection, switch off the supply properly.
4. All connection should be tight and clean.
5. The reading in instruments should not exceed from their permissible limit.
6. Don't touch the necked terminals as voltage is high.

Conclusion:- From the above experiment we learnt about the, connection & Reverse the direction of rotation of Three Phase Induction motor.

Experiment - 04

Aim- Study and Practice of connection & Reverse the direction of rotation of Single Phase Induction motor.

APPARATUS REQUIRED:-

Sl. No	Name of the Equipment	Specification	Quantity
1	1- ϕ Induction Motor	220v, 1500 RPM, 1HP	1no
2	Insulated Combination Pliers	150mm	1no
3	Screw driver	200mm	1no
4	Line Tester	1100v, 6'''	1no
5	Wire Stripper	150mm	1 no
6	D O L Starter	220V, 5A	1no
7	Wires	2.5 sq mm	As per required

Theory:-

Single phase motor consists of two winding such as main winding and auxiliary winding. They are not self-starting motor, because of they do not have rotating magnetic field such as three phase induction motors. Normally, for starting of single phase motor we use capacitors. The main power supply would be directly connected with the main winding and Capacitor is connected in series with the auxiliary winding and supply phase. Here capacitor is used to create the phase shift from existing phase. Hence the motor gets two phase and it starts rotating. Here we can change the motor direction by changing the capacitor connection. The capacitor can be connected in series with the main winding instead of auxiliary winding.

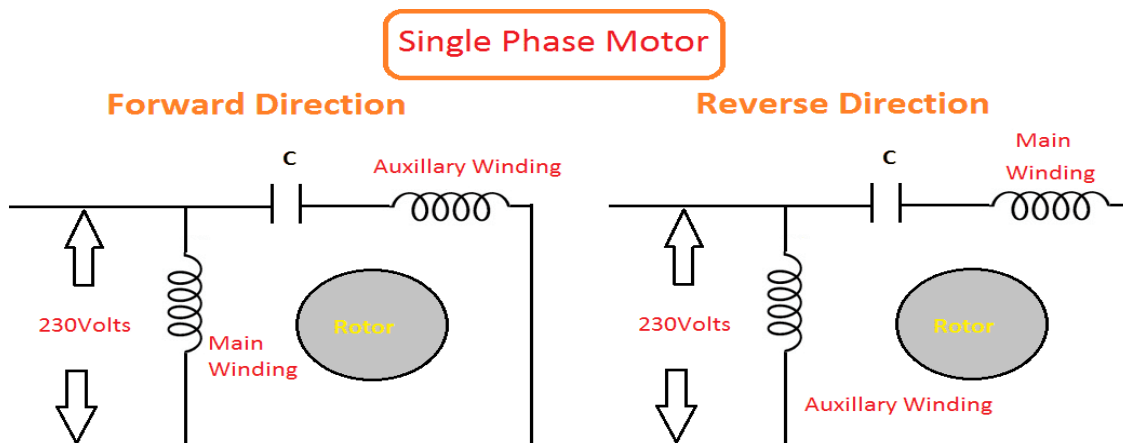

Procedure:-

1. Make sure that all the connection should be as per circuit diagram.
2. The main switch should be at off position before doing the connections.
3. Before changing the connection, switch off the supply properly.
4. All connection should be tight and clean.
5. The reading in instruments should not exceed from their permissible limit.
6. Don't touch the necked terminals as voltage is high.

Conclusion:- From the above experiment we learnt about the, connection & Reverse the direction of rotation of Single Phase Induction motor.

Experiment - 05

Aim- Heat run test of 3-phase transformer.

APPARATUS REQUIRED:-

Sl. No	Name of the Equipment	Specification	Quantity
1	3- ϕ Transformer	440v, 1 KVA	1no
2	Line Tester	1100v, 6"	1no
3	Wire Stripper	150mm	1 no
4	Voltmeter	500v	1no
5	Ammeter	15A	1no
6	Three Phase Variac	440V,15A	1no
7	Temperature Indicator	-	1no
8	Wires	2.5 sq mm	As per required

Theory:-

Heat run test is one of the type tests on power transformer. This test is also called temperature rise test. This test reproduces conditions of continuous rated load and the temperature rise occurring during the load. For conducting heat run test on the three phase transformer, full rated voltage is applied to one of the windings which accounts for full load iron losses and other winding is connected in delta, because of balanced condition of all three phases voltage in the delta loop is zero and with the help of external source full load current is circulated in the delta connected winding of the transformer to account for full load copper losses. With the help of RTD provided in the winding of transformer temperature of the transformer winding is recorded. Steady state temperature of winding indicates the full load temperature rise of the transformer.

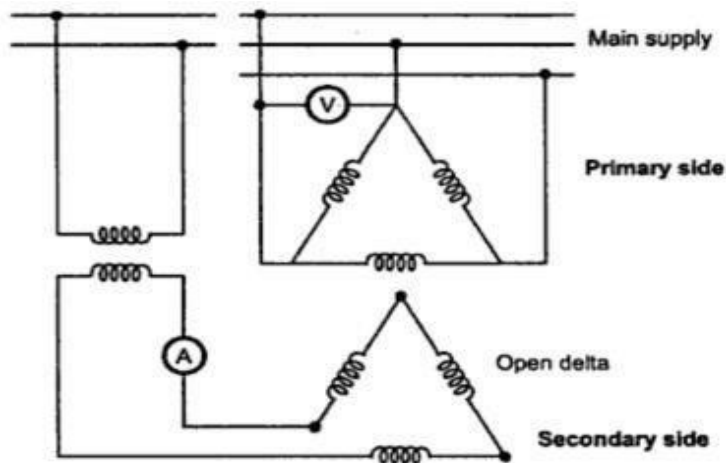

Procedure:-

1. Make the connections as per the circuit diagram given in fig. attached.
2. Increase the voltage in the primary winding with the help of 3 phase variac to rated voltage.
3. Adjust the current in the closed delta secondary winding to the rated current of the secondary winding.
4. Record the temperature of the winding after every 15 minutes till temperature of winding reaches to a steady state condition i.e. temperature does not rise any more.
5. Time taken to reach the final temperature give idea about the thermal time constant of the transformer and final temperature gives the full load temperature rise of the transformer.

Conclusion:- From the above experiment, we learnt about the heat run test of three phase transformer.

Experiment - 06

Aim- OC and SC test of alternator and determination of regulation by synchronous impedance method.

APPARATUS REQUIRED:-

Sl. No	Name of the Equipment	Specification	Quantity
1	DC Motor Coupled to Alternator	Motor- 220V DC, 3KW, 1500RPM Alternator- 440V, 3 KVA,50 Hz	1no
2	Line Tester	1100v, 6'''	1no
3	Wire Stripper	150mm	1 no
4	Voltmeter	500v	1no
5	Ammeter	15A	1no
6	Rheostat	750ohm, 1.5A	1no
7	Multimeter	-	1 no
7	Tachometer	0-9999 RPM, Digital	1no
8	Wires	2.5 sq mm	As per required

Theory:-

Open Circuit Test and Short Circuit Test are performed on a Synchronous Machine to find out the Synchronous impedance For Large Machine to determine-the voltage-regulation.

Open Circuit Test:-

The alternator is run at rated synchronous speed and the load terminals are kept open. That is, all the loads are disconnected. The field current is set to zero, this condition is called open circuit test condition.

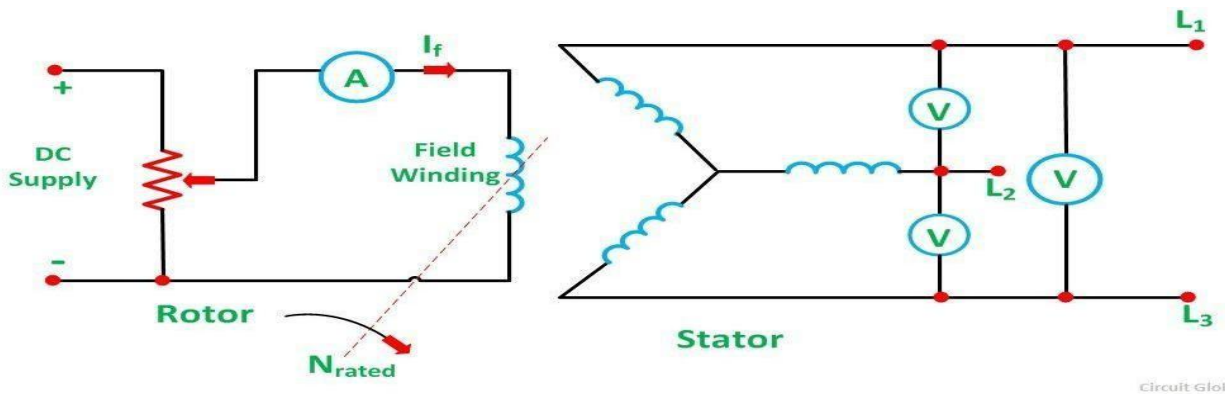

The field current is gradually increase in steps, and the terminal voltage E_t is measure at each step, The excitation current may be increased to get 25% more than rated voltage of the alternator. A graph is plotted between the open circuit test voltage E_p and field.

The characteristic curve so obtain is called open circuit characteristic (O.C.C.). it take the shape of a normal magnetization curve. the extension of linear portion of an O.C.C. is called the air gap line are show in figure.

Short Circuit Test:-

The armature terminals are shorted through three ammeter. Care should we taken performing this test, and the field current should first decrease to zero before starting the alternator. Each ammeter should have range greater than the full rated value. the alternator run at synchronous speed. then the field current gradually increased in step, and the armature current is measured at each step.

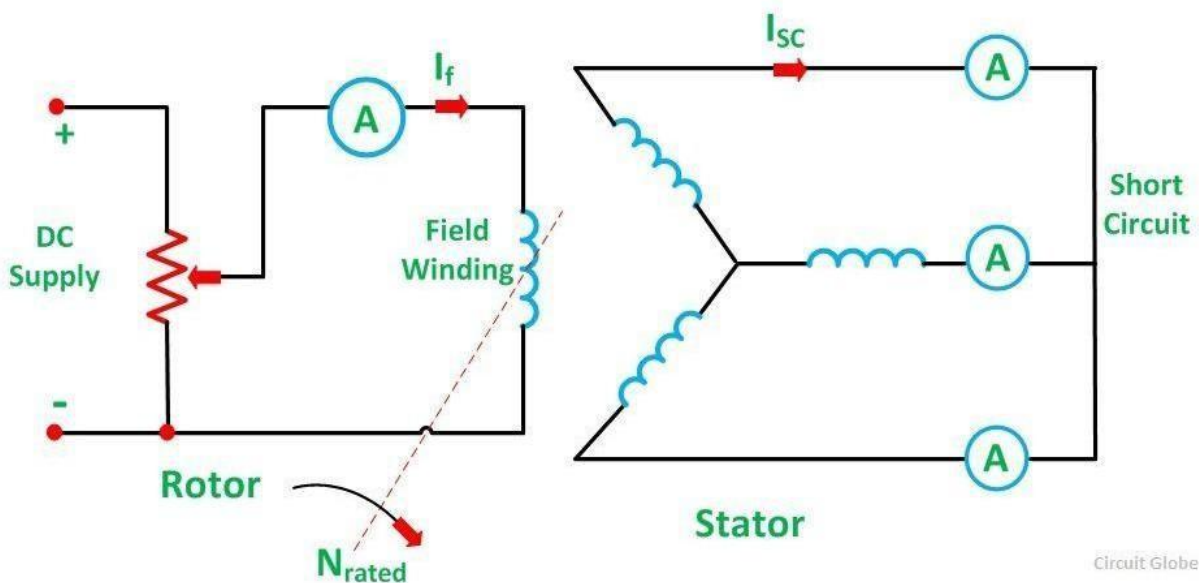

The field current may be increased to get armature current up to 150% of the rated value. The field current I_f and the average of three ammeter reading at each step is taken.

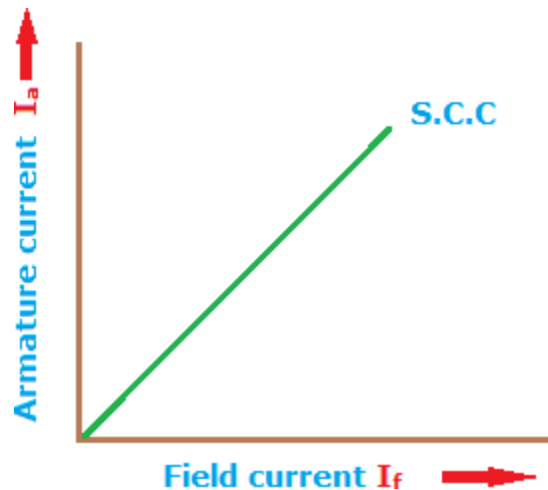

A graph is plotted between the armature current I_a and field current I_f . The characteristic so obtained is called short-circuit characteristic (SCC). the characteristic is a straight line as shown in figure.

Calculation of Synchronous Impedance:-

The following steps are given below for the calculation of the synchronous impedance.

- The open circuit characteristics and the short circuit characteristic are drawn on the same curve.
- Determine the value of short circuit current I_{sc} and gives the rated alternator voltage per phase.
- The synchronous impedance Z_s will then be equal to the open circuit voltage divided by the short circuit current at that field current which gives the rated EMF per phase.

$$Z_s = \frac{\text{Open circuit voltage per phase}}{\text{Short circuit armature current}} \quad (\text{for the same value of field current})$$

The synchronous reactance is determined as

$$X_s = \sqrt{Z_s^2 - R_a^2}$$

The graph is shown below.

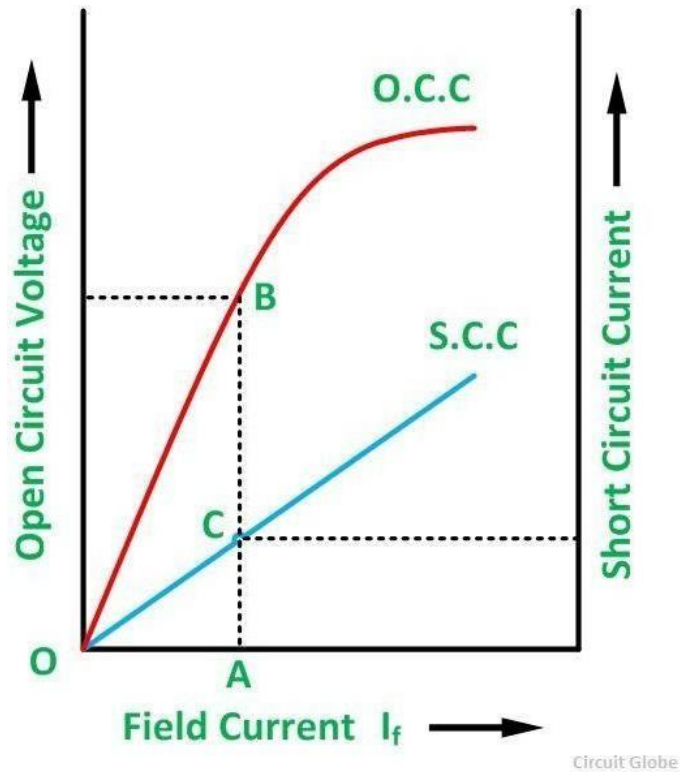

From the above figure consider the field current $I_f = OA$ that produces rated alternator voltage per phase. Corresponding to this field current, the open circuit voltage is AB

Therefore,

$$Z_s = \frac{AB \text{ (in volts)}}{AC \text{ (in amperes)}}$$

PROCEDURE:

- Connect the circuit as shown in the circuit diagram.
- Make sure the rheostat in d c motor field is at minimum position and rheostat in alternator field is at maximum position.
- Start D. C. Motor
- Set the speed of d. C. Shunt motor to 1500 rpm by field rheostat of d. C. Motor.

For O.C. test:-

- Note down the voltmeter reading when switch in field of alternator is open. This is voltage
- due to residual magnetism when field current is zero.
- Close the switch in field circuit (single pole), take down readings of D. C. Ammeter (I_f) and
- C. Voltmeter (VOC) by gradually reducing resistance in the field circuit of alternator.
- Take down readings up to VOC = 440 V. Field current of alternator should not exceed its
- rating.
- Increase resistance gradually, then directly switch off d. c. Supply.

For S. C. Test:-

- Connect Ammeter in R and Y terminal of alternator, Short Y and B terminals
- Make sure rheostat positions of both machine fields
 - a. Motor field rheostat - minimum, b. Alternator field rheostat – maximum position.
- Switch on D.C. supply, start d. C. Motor by 3 point starter.
- Adjust speed of d.c. motor at 1500 rpm by field rheostat.
- Close the single pole switch, d.c. ammeter will be at minimum reading.
- Take down d. C. Ammeter reading (I_f) and a.c. ammeter (ISC)reading by gradually reducing
- Field resistance of alternator.
- Short circuit current of alternator must be below 4.2A that is rated current of alternator.
- Increase resistance to max of alternator field and switch off d.c. supply.
- Remove connections.

OBSERVATION TABLE:-**Open Circuit Test:-**

Sl. No	I_f amps	Voc Volts
1		
2		
3		
4		
5		

Short Circuit Test:-

Sl. No	If amps	Vsc Volts
1		
2		
3		
4		
5		

Conclusion:- From the above experiment, we learnt about the, OC and SC test of alternator and determination of regulation by synchronous impedance method.

Experiment - 07

Aim- Determine of regulation of alternator by direct loading.

APPARATUS REQUIRED:-

Sl. No	Name of the Equipment	Specification	Quantity
1	DC Motor Coupled to Alternator	Motor- 220V DC, 3KW, 1500RPM Alternator- 440V, 3 KVA,50 Hz	1no
2	Line Tester	1100v, 6"	1no
3	Wire Stripper	150mm	1 no
4	Voltmeter	500v AC	1no
5	Ammeter	5A AC	4 nos
6	Rheostat	750ohm, 1.5A	1no
7	Multimeter	-	1 no
7	Tachometer	0-9999 RPM, Digital	1no
8	Frequency Meter	Digital Type	1 no
9	Three Phase Resistor Load	440V, 1K Ω	1no
10	Wires	2.5 sq mm	As per required

Theory:-

The Voltage Regulation of a Alternator is the rise in voltage at the terminals when the load is reduced from full load rated value to zero, speed and field current remaining constant. It depends upon the power factor of the load. For unity and lagging power factors, there is always a voltage drop with the increase of load, but for a certain leading power, the full load voltage regulation is zero.

The voltage regulation is given by the equation shown below.

$$\text{Per Unit Voltage Regulation} \triangleq \frac{|E_a| - |V|}{|V|} \dots \dots \dots (1)$$

$$\text{Percentage Voltage Regulation} \triangleq \frac{|E_a| - |V|}{|V|} \dots \dots \dots (2)$$

Where,

- $|E_a|$ is the magnitude of a generated voltage per phase
- $|V|$ is the magnitude of rated terminal voltage per phase

In this case, the terminal voltage is the same for both full load and no load conditions. At lower leading power factors, the voltage rises with the increase of load, and the regulation is negative.

Determination of Voltage Regulation:-

There are mainly two methods which are used to determine the regulation of voltage of a smooth cylindrical rotor type alternators. They are named as direct load test method and indirect methods of voltage regulation. The indirect method is further classified as Synchronous Impedance Method, Ampere-turn Method and Zero Power Factor Method.

Direct Load Test:-

The alternator runs at synchronous speed, and its terminal voltage is adjusted to its rated value V . The load is varied until the Ammeter and Wattmeter indicate the rated values at the given power factor. The load is removed, and the speed and the field excitation are kept constant. The value of the open circuit and no load voltage is recorded.

It is also found from the percentage voltage regulation and is given by the equation shown below.

$$\% \text{ Voltage Regulation} = \frac{E_a - V}{V} \times 100\%$$

The method of direct loading is suitable only for small alternators of the power rating less than 5 KVA.

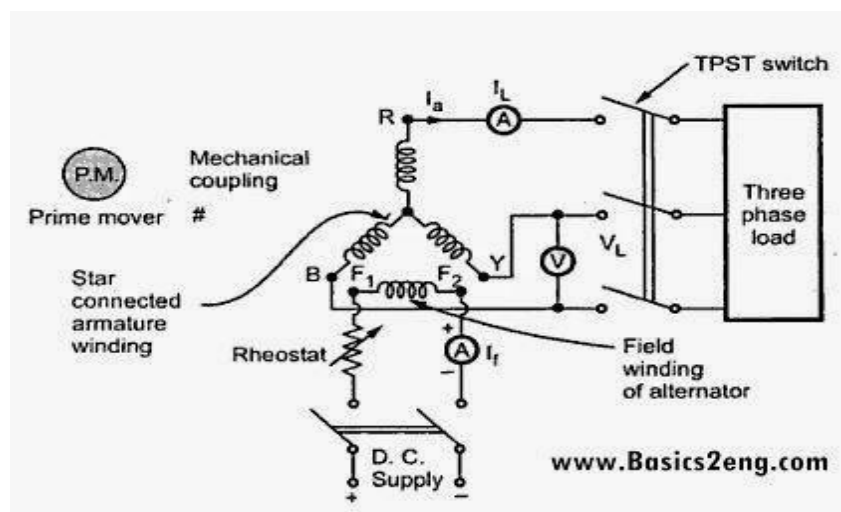

Procedure:-

- Connect the circuit as per the circuit diagram.
- Keep the field rheostat of d.c. motor at minimum position and field rheostat of alternator at maximum position.
- Switch on d.c. supply and start d.c. shunt motor.
- Adjust the speed of d.c. motor to 1500 r.p.m. Adjust rheostat in field circuit of alternator such that it gives rated voltage i.e. 400V. Take down voltmeter reading. This is no load voltage of alternator.
- Switch ON load such that ammeter of each phase indicate same reading.
- Check speed of motor, if it is reduced, adjust the speed to 1500 r.p.m. at this loading condition.
- Take down readings of ammeter and voltmeter by gradually increasing load. At each loading condition, speed should be adjusted to 1500 rpm.
- Switch off load bank.
- Adjust rheostat of alternator field to maximum position and switch off d.c. supply.
- Plot the graph.

Observation Table:-

Sl. No	I_a amps	V_L (volts)	N rpm
1			
2			
3			
4			
5			

Graph:-

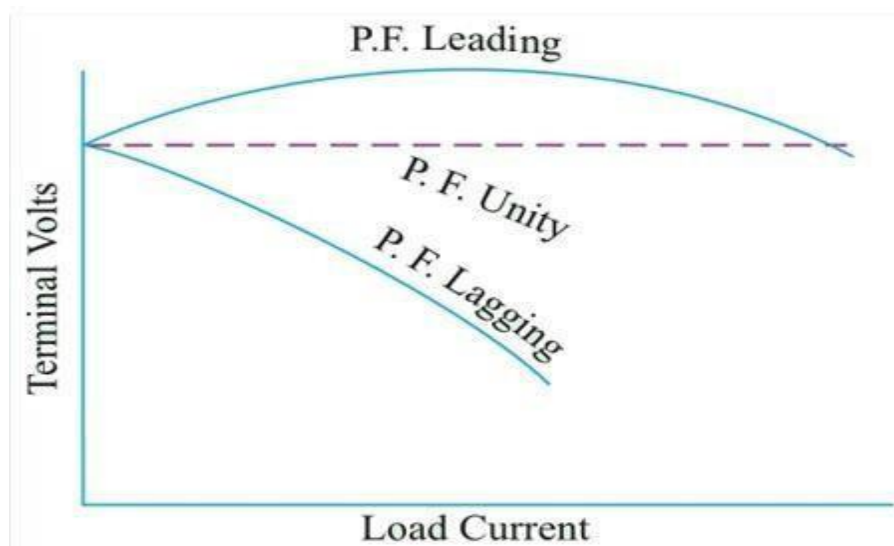

Conclusion:- From the above experiment, we learnt about the, regulation of alternator by direct loading.

Experiment - 08

Aim- Parallel operation of two alternators and study load sharing.

APPARATUS REQUIRED:-

Sl. No	Name of the Equipment	Specification	Quantity
1	DC Motor Coupled to Alternator	Motor- 220V DC, 3KW, 1500RPM Alternator- 440V, 3 KVA,50 Hz	2nos
2	Line Tester	1100v, 6"	1no
3	Wire Stripper	150mm	1 no
4	Voltmeter	500v AC	2nos
5	Ammeter	5A AC	2 nos
6	Rheostat	750ohm, 1.5A	2 nos
7	Multimeter	-	1 no
7	Frequency Meter	Digital Type	2 nos
8	Syncchonoscope	-	1 no
9	Lamps	100W	3nos
10	Wires	2.5 sq mm	As per required

Theory:-

Alternator is really an AC generator. In alternator, an EMF is induced in the stator (stationary wire) with the influence of rotating magnetic field (rotor) due to Faraday's law of induction. Due to the synchronous speed of rotation of field poles, it is also known as synchronous generator. Here, we can discuss about parallel operation of alternator. When the AC power systems are interconnected for efficiency, the alternators should also have to be connected in parallel. There will be more than two alternators connected in parallel in generating stations.

Condition for Parallel Operation of Alternator:-

There are some conditions to be satisfied for parallel operation of the alternator. Before entering into that, we should understand some terms which are as follows.

- The process of connecting two alternators or an alternator and an infinite bus bar system in parallel is known as synchronizing.
- Running machine is the machine which carries the load.

- Incoming machine is the alternator or machine which has to be connected in parallel with the system.

The conditions to be satisfied are:-

1. The phase sequence of the incoming machine voltage and the bus bar voltage should be identical.
2. The RMS line voltage (terminal voltage) of the bus bar or already running machine and the incoming machine should be the same.
3. The phase angle of the two systems should be equal.
4. The frequency of the two terminal voltages (incoming machine and the bus bar) should be nearly the same. Large power transients will occur when frequencies are not nearly equal.

Departure from the above conditions will result in the formation of power surges and current. It also results in unwanted electro-mechanical oscillation of rotor which leads to the damage of equipment.

Methods:-

There are two synchronizing methods -

- a. Using incandescent lamp
- b. Using synchroscope.

(a) Using Incandescent lamp :-

Let machine G2 be synchronized with machine G1 which is already connected with the bus bar, using three lamps (L1, L2 and L3) method.

These lamps are known as synchronizing lamps connected as shown in Fig.1

If the speed of machine 2 is not brought upto that of machine 1 then its frequency will also be different, hence there will be a phase difference between their voltages as shown in Fig.2.

Due to difference in frequencies the resultant voltage will undergo changes similar to the frequency changes of beats produced when two sound sources of nearly equal frequencies are sounded together.

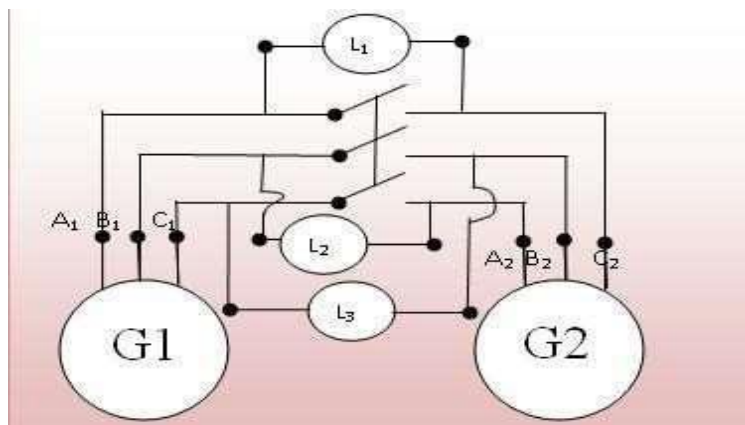

Fig. 1 Synchronization using three lamp method

The resultant voltage is sometimes maximum and sometimes minimum.

Hence, the lamps will flicker, sometimes dark and sometimes bright.

Synchronization is done at the middle of the dark period. This method of synchronizing is known as dark lamp method.

Lamp L1 is connected between A1 and A2, L2 between B1 and C2 and L3 between C1 and B2.

These three lamps slowly brighten and darken in cyclic successor in a direction depending upon whether incoming machine 2 is fast or slow.

The synchronizing switch will be closed at the moment when lamp L1 will be completely dark.

This method has following drawbacks:

1. The lamps become dark at about one third of the rated voltage. Hence, faulty synchronizing may be done in dark period.
2. Using this method it is not possible to find out that how much the machine is slow or fast.
3. This method is not applicable for high voltage alternators, because lamp ratings are normally low. For such situations we need an extra transformer to step down the voltage.

(b) SYNCHRONIZING BY SYNCHROSCOPE:

Synchroscope is a device that shows the correct instant of closing the synchronizing switch with the help of a pointer which will rotate on the dial.

The rotation of pointer also indicates whether the incoming machine is running too slow or too fast.

If incoming machine is slow then pointer rotates in anticlockwise direction and if machine is fast then pointer rotates in clockwise direction.

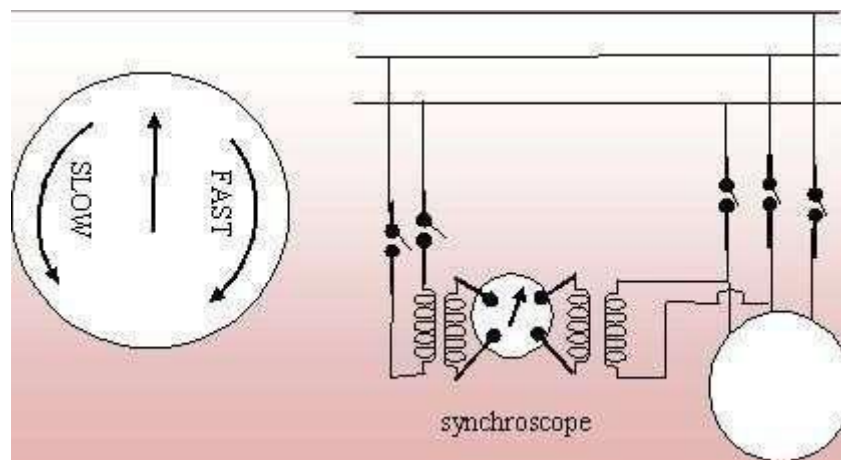

Fig. 3 Synchronizing by Synchroscope

PROCEDURE:-

1. Make the connection diagram as shown in figure 1.1
2. Run one of the alternators and adjust its voltage at rated value and close switch to bus bar.
3. Start the second set (alternator 2), bring it upto proper speed equal to that of the running alternator (or bus bar voltage).
4. Synchronize the incoming alternator by any one method described in theory.

Observations :-

1. Measure and adjust voltage of incoming machine (V_g) and bus bar (V_s) till $V_g = V_s$.
2. Measure and adjust the speed of incoming machine, till synchroscope needle creeps.
3. Close synchronizing switch

Conclusion:- From the above experiment, we learnt about the, Parallel operation of two alternators and study load sharing.

Experiment - 09

Aim- Measurement of power of a 3-phase Load using two wattmeter method and verification of the result using one 3-phase wattmeter.

APPARATUS REQUIRED:-

Sl. No	Name of the Equipment	Specification	Quantity
1	Wattmeter	250V, 5A	2nos
2	Three Phase Wattmeter	440V, 10A	1no
3	Line Tester	1100v, 6'''	1no
4	Wire Stripper	150mm	1 no
5	Voltmeter	(0-300)v	2nos
6	Ammeter	(0-5)A	2nos
7	Three Phase Resistive Load	440V,5A	1no
8	Three Phase Inductive Load	-	1no
9	Wires	2.5 sq mm	As per required

Theory:-

Surprisingly, only two single phase wattmeters are sufficient to measure the total power consumed by a three phase balanced circuit. The two wattmeters are connected as shown in figure. The current coils are connected in series with two of the lines. The pressure (or voltage) coils of the two wattmeters are connected between that line and reference.

CIRCUIT DIAGRAM :-

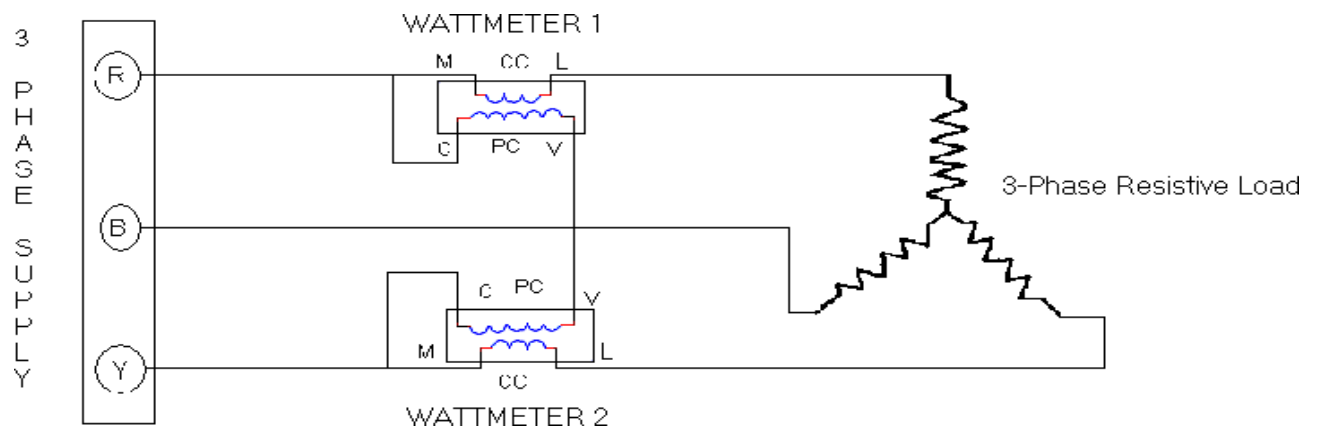

PROCEDURE :-

1. Connect the circuit as shown in figure.
2. Keep the three phase variac at its zero position .
3. Switch on the main supply.
4. Increase the voltage supplied to the circuit by changing the positions of variac so that all the meters give readable deflection.
5. Note down readings of all the meters

Tabulation:-

Sl. No	Load Voltage in Volt	Load Current In Ampere	Wattmeter (W ₁)Reading In Kwh	Wattmeter (W ₂)Reading In Kwh	P= W ₁ + W ₂
1					
2					
3					
4					
5					

PRECAUTIONS :

1. Connections should be tight.
2. Take the readings carefully.
3. Switch off the circuit when not in use.

VARIFICATION OF RESULT USING ONE 3-PHASE WATTMETER

THEORY:

Three phase reactive power can be measured by two wattmeter method which is universally adopted Method. The difference between higher reading wattmeter and lower wattmeter reading yields $V_L I_L \sin \phi$. so, the total 3 reactive power is $\sqrt{3} V_L I_L \sin \phi$

Reactive power in a balance 3- ϕ load can also be calculated by using single wattmeter. In this method, the current coil of the wattmeter is connected in any on line and the pressure coils across the other two lines. Let us assume that the Current coil is connected in R phase and pressure coil is connected across „Y” and „B” phases. Assuming phases. Assuming phase sequence RYB and an inductive load of an angle „ ϕ ” the phasor diagram for the circuits is as follows.

Here current through current coil = IR
Voltage across pressure coil = VYB

The phase angle between VYB and IR from the phasor diagram is $90^\circ - \phi$ Wattmeter reading is
 $VYB IR \cos (90^\circ - \phi)$

$$W = VYB IR \sin (90^\circ - \phi)$$

In terms of line current and voltage

$$W = VYB IR \cos (90^\circ - \phi)$$

Items of line current and voltage

$$W = VL IL \sin \phi$$

The total 3- ϕ reactive power is $\sqrt{3} VL IL \sin \phi$

CIRCUIT DIAGRAM

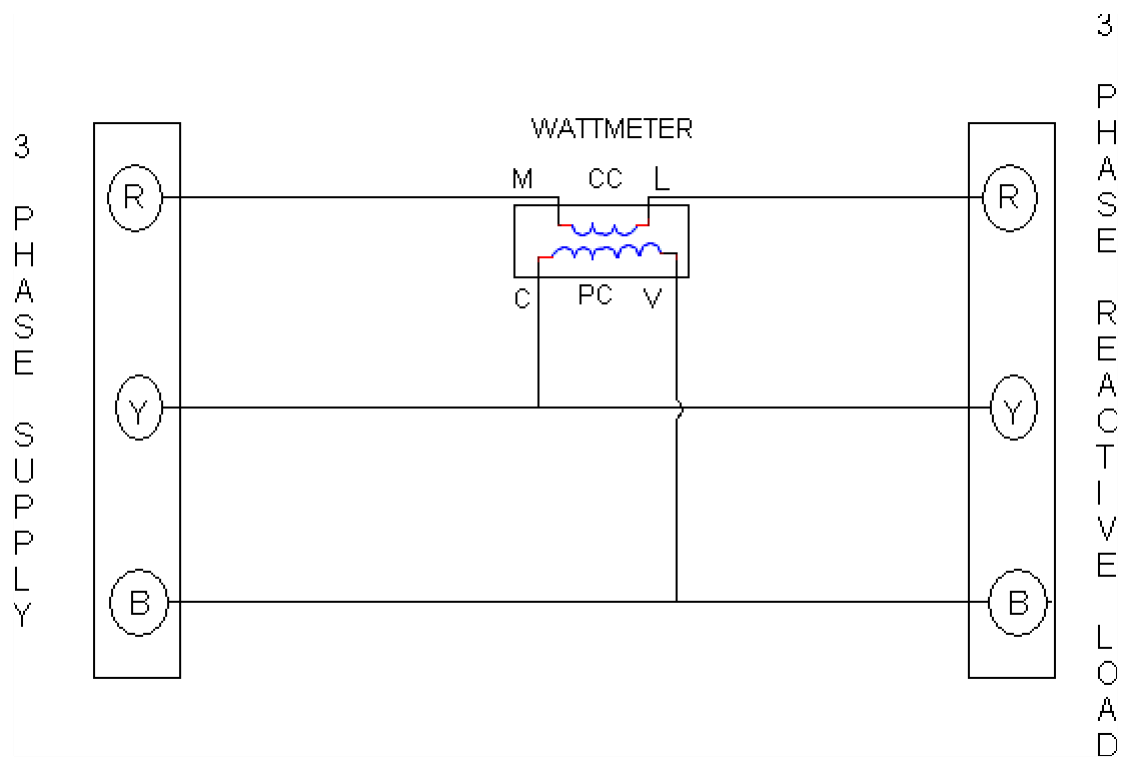

PROCEDURE:

1. Connect the circuit as shown in fig.
2. Switch „ON“ the supply.
3. Note down the corresponding there reading and calculate 3- ϕ reactive power.
4. Now increase the load of three phase Inductive load steps and note down the corresponding meter readings.
5. Remove the load and switch „off“ the supply.

TABULAR COLUMN:

Sl. No	3 Phase Load	Wattmeter Reading	3 Phase Reactive Power
1	1 A		
2	2 A		
3	3 A		
4	4 A		
5	5 A		

Conclusion:- From the above experiment, we learnt about the, Measurement of power of a 3-phase Load using two wattmeter method and verification of the result using one 3-phase wattmeter.

Experiment - 10

Aim- Connection of 3-phase energy meter to a 3-phase load.

APPARATUS REQUIRED:-

Sl. No	Name of the Equipment	Specification	Quantity
1	Three Phase Energy Meter with four wire	440V, 16A,	1no
2	Three Phase Resistive Load	440V,5A	1no
3	Insulated Combination Pliers	150mm	1no
4	Line Tester	1100v, 6"	1no
5	Wire Stripper	150mm	1 no
6	Wires	2.5 sq mm	As per required

Theory:-

ThreePhaseEnergyMeter:-

The meter which is used for measuring the power of three phase supply is known as the three phase energy meter. The three phase meter is constructed by connecting the two single phase meter through the shaft. The total energy is the sum of the reading of both the elements.

WorkingPrincipleof Three Phase EnergyMeter:-

The torque of both the elements is added mechanically, and the total rotation of the shaft is proportional to the three phase energy consumption.

ConstructionofThreePhaseEnergyMeter:-

The three phase energy meter has two discs mounted on the common shaft. Both the disc has its braking magnet, copper ring, shading band and the compensator for getting the correct reading. The two elements are used for measuring the three phase power. The construction of the three phase meter is shown in the figure below.

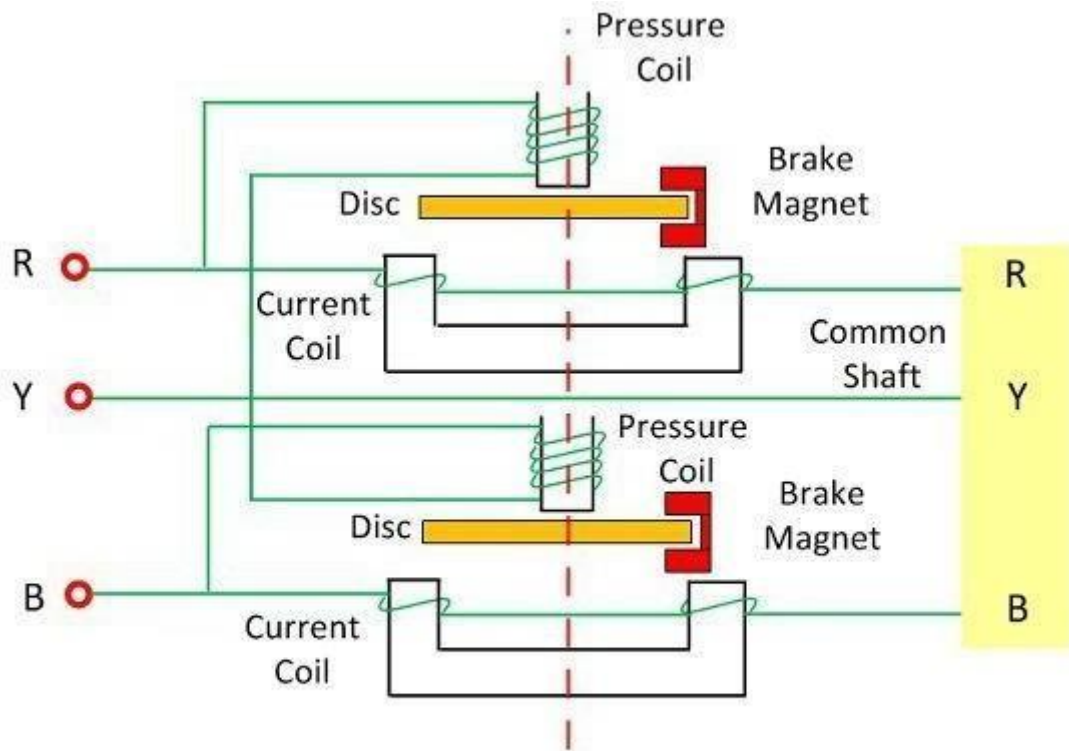

Three Phase Energy Meter

Circuit Globe

For three phase meter, the driving torque of both the elements is equal. This can be done by adjusting the torque. The torque is adjusted by connecting the current coils of both the elements in the series and their potential coils in parallel. The full load current is passed through the coil due to which the two opposite torque is set up in the coil.

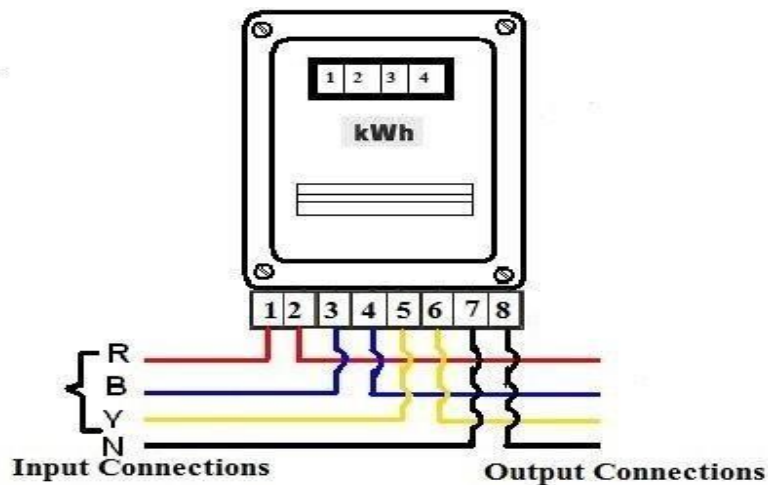

Three Phase Energy Meter Connections

The strength of both the torques is equal, and hence they do not allow the disc to rotate. If the torque becomes unequal and the disc rotates then the magnetic shunt is adjusted. The balance torque is obtained before testing the meter. The position of the compensator and the braking magnet are separately adjusted to each of the element for obtaining the balance torque.

Procedure:-

- We should take all the tools and material.
- Make the connection as per circuit diagram.
- All the connection should be tight.
- Switch on the supply.
- Observe the output.

Conclusion:- From the above experiment, we learnt about the, connection of 3-phase energy meter to a 3-phase load.

Experiment - 11

Aim- Study of an O.C.B.

APPARATUS REQUIRED:-

Sl. No	Name of the Equipment	Specification	Quantity
1	Oil Circuit Breaker	1KVA	1no
2	Insulated Combination Pliers	150mm	1no
3	Line Tester	1100v, 6'''	1no
4	Wire Stripper	150mm	1 no
5	Wires	2.5 sq mm	As per required

Theory:-

Oil circuit breaker is such type of circuit breaker which used oil as a dielectric or insulating medium for arc extinction. In oil circuit breaker the contacts of the breaker are made to separate within an insulating oil. When the fault occurs in the system the contacts of the circuit breaker are open under the insulating oil, and an arc is developed between them and the heat of the arc is evaporated in the surrounding oil.

Construction of Oil Circuit Breaker

Oil circuit breaker is very easy in construction. It consists of current carrying contacts enclosed in a strong, weather-tight earth metal tank and the tank is filled with transformer oil. The oil is both acts as an arc extinguishing medium and as an insulator between the live part and earth.

At the top of the oil, air is filled in the tank which acts as a cushion to control the displaced oil on the formation of gas around the arc and also to absorb the mechanical shock of the upward movement of oil. The breaker tank is securely bolted for carrying out the vibration caused on interrupting very high current. Oil circuit breaker consists gas outlet which is fitted in the tank cover for the removal of the gases.

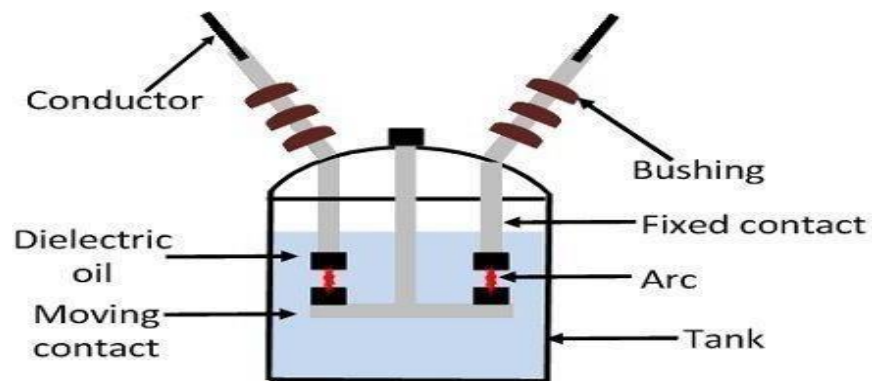

Oil Circuit Breaker

Circuit Globe

Working Principle of Oil Circuit Breaker:-

During the normal operating conditions, the contact of the oil circuit breaker is closed and carry the current. When the fault occurs in the system, the contacts of the breaker are moving apart, and an arc is struck between the contacts.

Due to this arc, a large amount of heat is liberated, and a very high temperature is reached which vaporizes the surrounding oil into gas. The gas, thus liberated surrounds the arc and its explosive growth around it displace the oil violently. The arc is extinguished when the distance between the fixed and moving contact reaches a certain critical value, depends on the arc current and recovery voltage.

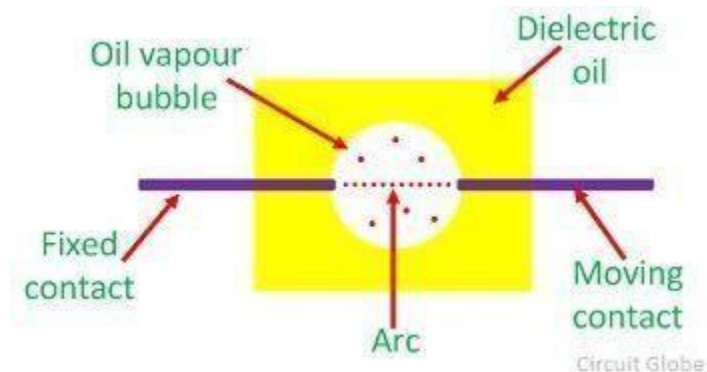

The oil circuit breaker is very reliable in operation, and it is very cheap. The most important feature of oil circuit breaker is that no special devices are used for controlling the arc caused by moving contact. The oil as an arc quenching medium has certain advantages and disadvantages

Types:-

Bulk Oil Circuit Breakers:-

This kind of circuit breaker uses a large amount of oil for the destruction of arc. It is also called a dead tank circuit breaker. As the name suggests, the tank of this breaker is held at ground potential. The amount of oil used in this circuit breaker mainly depends on the system voltage. For instance, if the system voltage is 110 kV, it uses 8 kg to 10,000 kg of oil. Similarly, for 220 kV, it uses 50,000 Kg of oil. In this type of circuit, oil works like an arc extinguishing medium & insulates the existing parts from the earth.

Minimum Oil Circuit Breaker:-

This type of circuit breaker uses less oil. The oil tank is placed on a porcelain insulator for insulating it from the ground. It includes an arc chamber that is enclosed within a bakelite paper.

This circuit breaker includes two portions; the upper portion is porcelain that is enclosed with contacts whereas the lower portion is supported through the porcelain

It uses less space as compared with bulk oil type. It is not used where the repeated operation is necessary. The main benefits of this circuit breaker are, it uses less oil, less space, less weight, tank size is small, less maintenance, etc.

Maintenance of Oil Circuit Breaker:-

For every type of circuit breaker, maintenance is required. Similarly in oil type also, it is essential to verify and change the oil as well as contacts. Once the short circuit occurs, then a circuit breaker is interrupted. Sometimes, the contacts may get damaged because of arcing. So, the dielectric oil may get carbonized within the region of the contacts then its dielectric strength can be reduced and breaking capacity can be decreased. As a result, the maintenance of the breaker is necessary for verifying, replacing the oil & contacts.

The following points must be check before inspecting the circuit breaker

- Observe the internal parts & arcing contacts. Once it gets a short circuit then the contacts must be changed.
- Observe the coil"s dielectric strength
- The surface of the breaker must be cleaned & eliminate carbon deposits through a dry fabric & strong.
- Verify the level of oil.
- Tripping as well as closing mechanism must be checked.

Conclusion: - From the above experiment, we learnt about the, oil circuit breaker of transformer.

Experiment - 12

Aim- Study of an induction type over current/ reverse power relay.

APPARATUS REQUIRED:-

Sl. No	Name of the Equipment	Specification	Quantity
1	Induction Type Over Current Relay	440V, 16A	1no
2	Insulated Combination Pliers	150mm	1no
3	Line Tester	1100v, 6'''	1no
4	Wire Stripper	150mm	1 no
5	Wires	2.5 sq mm	As per required

Theory:-

The directional power relay is unsuitable for use as a directional protective relay under short-circuit conditions. When a short-circuit occurs, the system voltage falls to a low value and there may be insufficient torque developed in the relay to cause its operation. This difficulty is overcome in the Induction Type Directional Over current Relay which is designed to be almost independent of system voltage and power factor

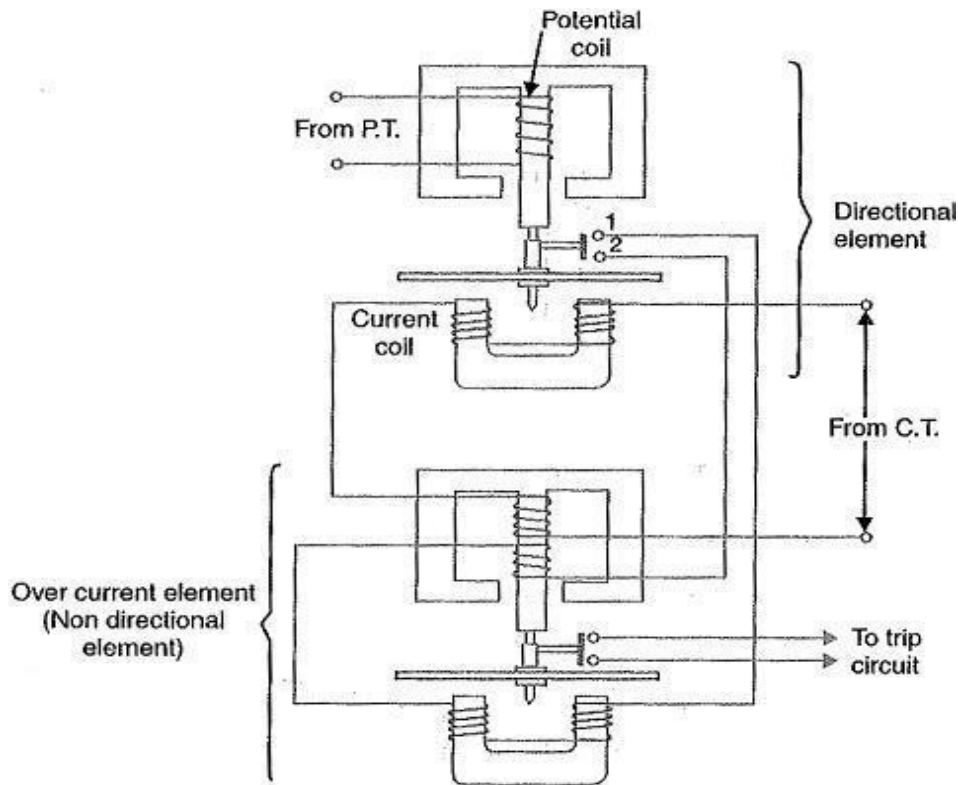

Fig. 21.19

Constructional details: Fig. 21.19 shows the constructional details of a typical Induction Type Directional Over current Relay. It consists of two relay elements mounted on a common case viz.

1. **Directional element and**
2. **Non-directional element.**

1. Directional element:

It is essentially a directional power relay which operates when power flows in a specific direction. The potential coil of this element is connected through a potential transformer (P.T.) to the system voltage. The current coil of the element is energized through a C.T. by the circuit current. This winding is carried over the upper magnet of the non-directional element. The trip contacts (1 and 2) of the directional element are connected in series with the secondary circuit of the over current element. Therefore, the latter element cannot start to operate until its secondary circuit is completed. In other words, the directional element must operate first (i.e. contacts 1 and 2 should close) in order to operate the over current element.

3. Non-directional element:-

It is an over current element similar in all respects to a non-directional over current relay described in Art. 21.11. The spindle of the disc of this element carries a moving contact which closes the fixed contacts (trip circuit contacts) after the operation of directional element.

It may be noted that plug-setting bridge is also provided in the relay for current setting but has been omitted in the figure for clarity and simplicity. The tapings are provided on the upper magnet of over current element and are connected to the bridge.

Operation:

Under normal operating conditions, power flows in the normal direction in the circuit protected by the relay. Therefore, Induction Type Directional Over current Relay (upper element) does not operate, thereby keeping the over current element (lower element) unexercised. However, when a short-circuit occurs, there is a tendency for the current or power to flow in the reverse direction. Should this happen, the disc of the upper element rotates to bridge the fixed contacts 1 and 2. This completes the circuit for over current element.

The disc of this element rotates and the moving contact attached to it closes the trip circuit. This operates the circuit breaker which isolates the faulty section. The two relay elements are so arranged that final tripping of the current controlled by them is not made till the following conditions are satisfied:

1. Current flows in a direction such as to operate the directional element.
2. Current in the reverse direction exceeds the pre-set value.
3. Excessive current persists for a period corresponding to the time setting of over current element.

Conclusion:- From the above experiment, we learnt about the, induction type over current relay.

Experiment - 13

Aim- Study of Buchholz's Relay.

APPARATUS REQUIRED:-

Sl. No	Name of the Equipment	Specification	Quantity
1	Buchholz's Relay Testing Kit	-	1no
2	Insulated Combination Pliers	150mm	1no
3	Line Tester	1100v, 6'''	1no
4	Wire Stripper	150mm	1 no
5	Wires	2.5 sq mm	As per required

Theory:-

The Buchholz relay protects the transformer from internal faults. It is the gas actuated relay. The Buchholz relay is placed between the main tank and the conservator. Such type of relay is used in the transformer having the rating higher than 500KVA. It is not used in small transformer because of economic consideration.

Working Principle of Buchholz Relay:-

When the fault occurs inside the transformer, the temperature of the oil increases. The oil evaporates in the form of the gas. The generation of the gas depends on the magnitude of the fault occurs inside the transformer. The internal failure occurs in the transformer either because of the insulation breakdown between the winding or the winding have the weak initial contact.

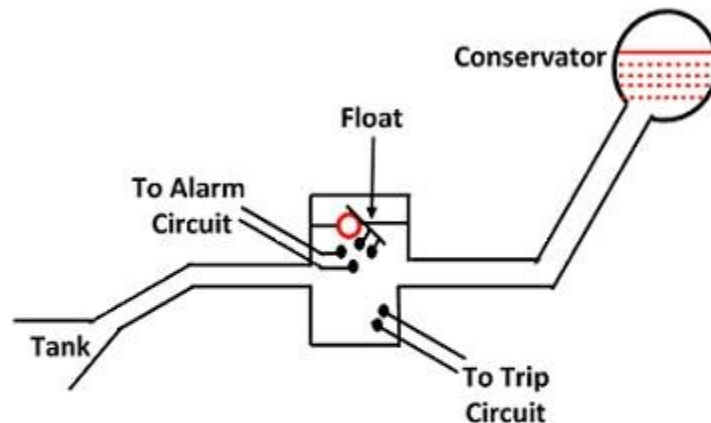

Arrangement of Buchholz Relay

Circuit Globe

The fault induces the arc which increases the temperature of the gas. The oil becomes evaporated and moves upwards. The Buchholz relay detects the failure and gives the alarm to the personnel. The transformer is disconnected from the main supply for maintenance.

Construction of Buchholz Relay:-

The Buchholz relay has two hinged which is placed in the metallic chamber. This metallic chamber is connected through the pipe between the conservator and main tank.

The one of the hinged is placed in the upper portion of the metallic chamber along with the mercury switch. This mercury switch is used for activating the alarm. The other float is placed in the lower portion of the metallic chamber along with the mercury switch. The mercury switch is used for actuating the tripping circuit.

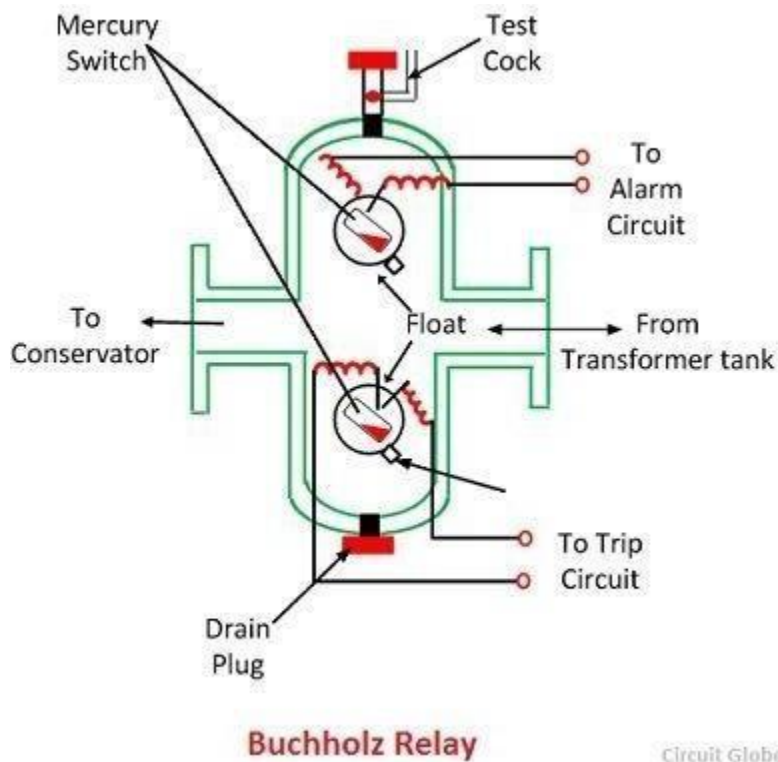

Operation of Buchholz Relay

The internal fault of the transformer induces the arc inside the main tank. The oil of the transformer starts heating because of the thermal effect. The gas moves upwards, and few of their vapours are collected in the upwards area of the main tank. Because of the evaporation, the level of oil inside the transformer tank starts decreasing.

The mercury switch placed inside the metallic chamber becomes tripped, and the relay gives the alarm to the personnel. The supply of the transformer becomes close, and it is disconnected to the system for maintenance. The relay has test cock which is used for releasing the pressure of the chamber.

When the severe fault occurs inside the transformer, the lower mercury switch placed inside the metallic chamber becomes slightly tilted because of which the tripping circuit becomes closed. Thus, the transformer is disconnected from the main circuit.

Limitations of Buchholz Relay:-

The following are the disadvantages of Buchholz relay.

1. The relay is used only in oil immersed transformer.
2. It can only detect the fault below oil level.
3. This relay does not protect the connecting cables. Hence separate protection is used for the cables.
4. The response time of the relay is high.
5. The minimum operating time of the relay is 0.1 seconds.

Procedure:-

- i Close all the balls.
- ii Press the air compressor in order to increase the pressure.
- iii Immediately open the valve number 1.
- iv Oil from the tank rushes into the Buchholz relay & fill it completely.
- v Open the output valve of Buchholz relay.
- vi Oil will rush out from the Buchholz relay into tank.
- vii When the oil reaches at the half level, the buzzers starts ringing to show that the low recipient fault has occurred.

Conclusion: - From the above experiment, we learnt about the, Buchholz"s relay.

Experiment - 14

Aim- Study of an Earth Fault Relay.

APPARATUS REQUIRED:-

Sl. No	Name of the Equipment	Specification	Quantity
1	Earth Fault Relay Testing Kit	-	1no
2	Insulated Combination Pliers	150mm	1no
3	Line Tester	1100v, 6 ^{mm}	1no
4	Wire Stripper	150mm	1 no
5	Wires	2.5 sq mm	As per required

Theory:-

The function of a relay is to detect abnormal conditions in the system and to initiate through appropriate circuit breakers the disconnection of faulty circuits so that Interference with the general supply is minimized.

Earth fault protection can be provided with normal over current relays, if the minimum earth fault current is sufficient in magnitude. The design of a comprehensive protection scheme in a power system requires the detailed study of time-current characteristics of the various relays used in the scheme. Thus it is necessary to obtain the time current characteristics of these relays. The over current relay works on the induction principle. The moving system consists of an aluminum disc fixed on a vertical shaft and rotating on two jeweled bearings between the poles of an electromagnet and a damping magnet. The winding of the electromagnet is provided with seven taps (generally 0, which are brought on the front panel, and the required tap is selected by a push-in -type plug. The pick-up current setting can thus be varied by the use of such plug multiplier setting. The pick-up current values of earth fault relays are normally quite low.

Operation:

With supply on load are continuously monitored Electronic comparator checks this value with set value (N) of phase & earth fault trip, which can be adjusted on front plate. Pick up response is (1.1 N) IDMT timing is applicable to over current above 2N as per chosen curve. Time setting multiplier for actual tripping time delay. TMS is adjusted by 11-position switch & with variable preset pot. These pots adjusted time for intermediate values indicated on TMS switch. Tripping cause is indicated by LED lamp (OC/EF). When over current trips the circuit relay „ NO“ contact changes to „NC“ when relay trips indicating LED to „NC“ when relay trip indicating LED to „NC“ when relay trips indicating LED to „NC“ when relay trip indicating LED flag will remain ON till manually reset.

Circuit Diagram:-

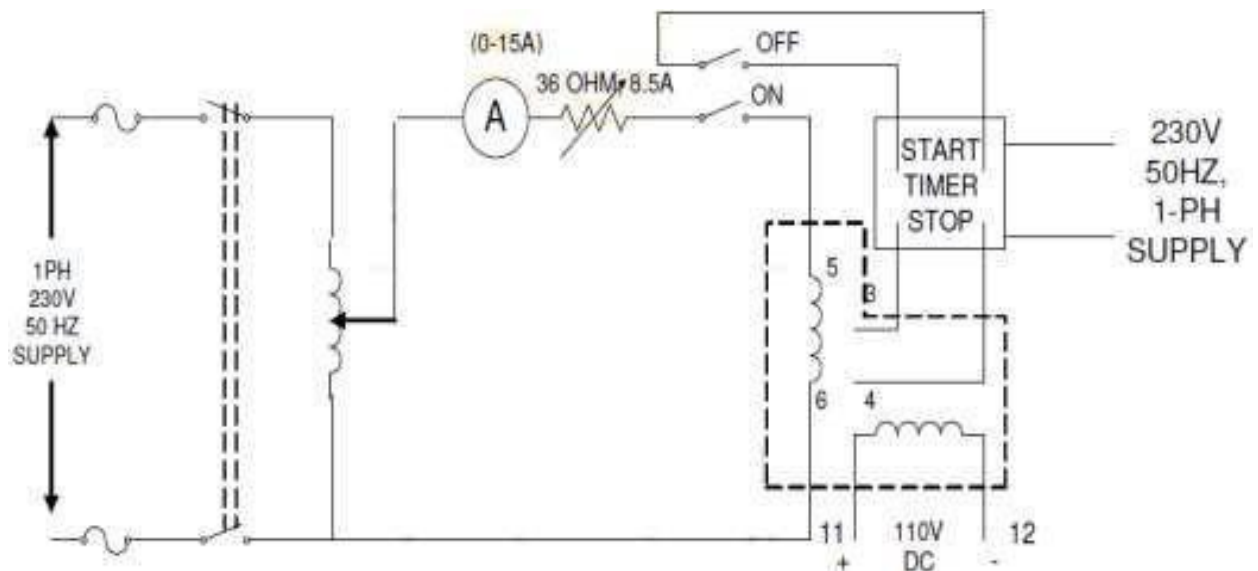

Procedure: -

1. Make the connection as shown in fig.
2. Set current and time setting of relays as per requirement
3. Set phase trip to 50% and set phase time at X1 with phase TMS at maximum position.
4. Switch on variac and check power ON indication provided on relay front panel.
5. Very dimmer state with fault current of 1A, relay will trip after certain time delay.
6. Switch OFF dimmer state without disrobing its position and change the position of DPT switch. Also reset time.
7. Switch ON dimmer state changes the position of switch and measure the relay time from timer.
8. Reap eat same procedure for varying a different fault current.
9. Repeat this procedure consider different set phase time (TMS)

Observation Table:-

Current setting =Phase TMS

Sr. No.	Fault Current (A)	PSM	Timer time for TSM=	Timer time for TSM=	Timer time for TSM=

Conclusion: - From the above experiment, we learnt about the, Earth Fault relay.