

Hydraulic Machines and Industrial Fluid Power



Prepared by:
Manoj Kumar Nayak
Assistant Professor
Mechanical Engineering Department
C V Raman Polytechnic
Bhubaneswar-751019

Hydraulic Turbines

Hydraulic turbines are those which convert hydraulic energy to Mechanical energy and then to electrical energy upon coupling to shafts or motors. At present hydro power generation is the cheapest as compared to other types of electrical energy. In this chapter the detailed design parameters of various types of turbines such as Pelton turbine, Francis turbine and Kaplan Turbine are discussed.

Classification of Turbines:

1. According to type of energy at Inlet
 - a) Impulse Turbine: Requires High Head and Low Rate of Flow.
Ex: Pelton Wheel
 - b) Reaction Turbine: Requires Low Head and High Rate of Flow.
Ex: Francis, Kaplan
2. According to direction of flow through runner
 - a) Tangential Flow Turbine - Pelton Wheel
 - b) Radial Flow Turbine - Francis Turbine
 - c) Axial Flow Turbine - Kaplan Turbine
 - d) Mixed Flow Turbine - Modern Francis Turbine
3. According to Head at Inlet of turbine
 - a) High Head Turbine - Pelton Wheel
 - b) Medium Head Turbine - Francis Turbine
 - c) Low Head Turbine - Kaplan Turbine
4. According to Specific Speed of Turbine
 - a) Low Specific Speed Turbine - Pelton Wheel
 - b) Medium Specific Speed Turbine - Francis Turbine
 - c) High Specific Speed Turbine - Kaplan Turbine
5. According to Disposition of Turbine Shaft
 - a) Horizontal Shaft - Pelton Wheel
 - b) Vertical Shaft - Francis & Kaplan Turbines
6. According to Disposition of Turbine Shaft
 - a) Low specific speed turbine - Pelton Wheel Turbine
 - b) Medium specific turbine - Francis Turbine
 - c) High specific turbine - Kaplan Turbines

Pelton wheel turbine:



**Main
components
of Pelton
Wheel
turbine:**

- Nozzle
- Runner and buckets
- Casing
- Breaking jet

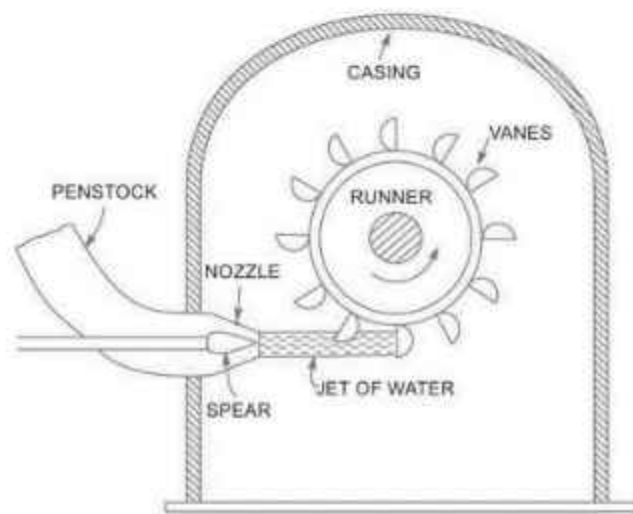

Design parameters or guidelines for the design of Pelton Wheel

- Jet Ratio = Pitch Diameter of wheel / Dia. of Jet = D/d
- Speed Ratio = Velocity of Wheel / Velocity of Jet = u/V
- Water Power, = $\frac{1}{2}mV^2 = gQH$
- No. of Buckets = $(0.5 \times \text{Jet Ratio}) + 15$

Francis turbine:

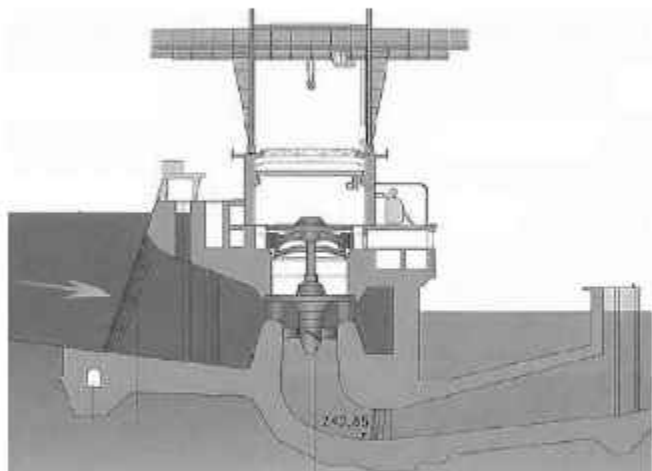
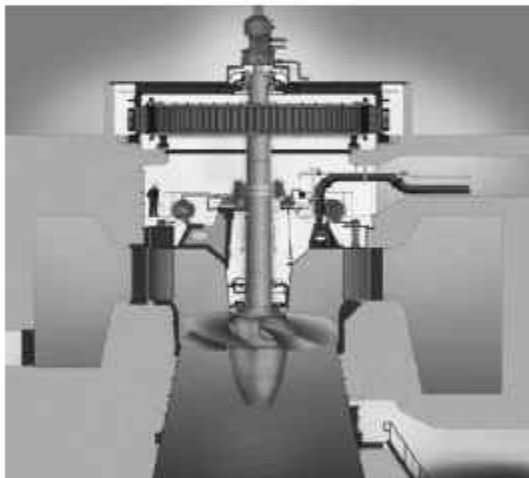

Higher specific speed corresponds to a lower head. This requires that the runner should admit a comparatively large quantity of water. For a runner of given diameter, the maximum flow rate is achieved when the flow is parallel to the axis. Such a machine is known as axial flow reaction turbine. An Australian engineer, Vikton Kaplan first designed such a machine. The machines in this family are called Kaplan Turbines.

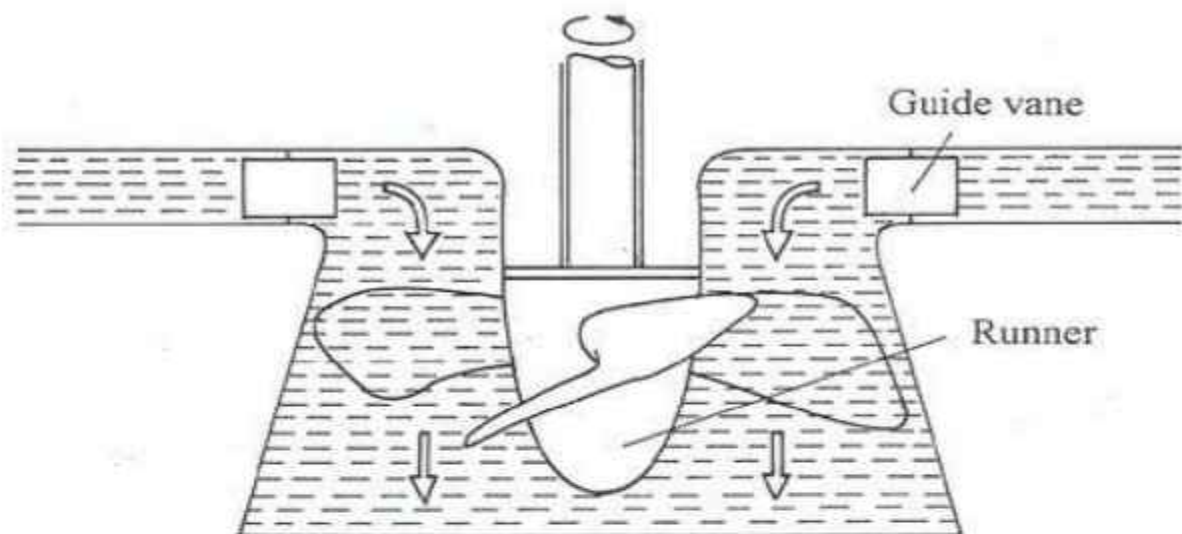

Guidelines for the designing of Kaplan turbine:

- Velocity of Wheel: $U = U_1 = U_2 = \frac{\pi D_m N}{60}$

Where,

- Work done per second: $X Q (V_{w1} - V_{w2}) X U$

- Velocity of Flow at Inlet and Outlet are equal $V_{f1} = V_{f2}$
- Discharge
- Flow Ratio

$$Q = \frac{X}{4} \sqrt{v_f}$$

$$D^2 - D'^2$$
$$XV$$

$$\sqrt{2XgXh}$$

Draft Tube

The water after working on the turbine, imparts its energy to the vanes and runner, thereby reducing its pressure less than that of atmospheric Pressure. As the water flows from higher pressure to lower Pressure, it cannot come out of the turbine and hence a divergent tube is Connected to the end of the turbine. Draft tube is a divergent tube one end of which is connected to the outlet of the turbine and other end is immersed well below the tailrace (Water level). The major function of the draft tube is to increase the pressure from the inlet to outlet of the draft tube as it flows through it and hence increase it more than atmospheric pressure. The other function is to safely Discharge the water that has worked on the turbine to tailrace.

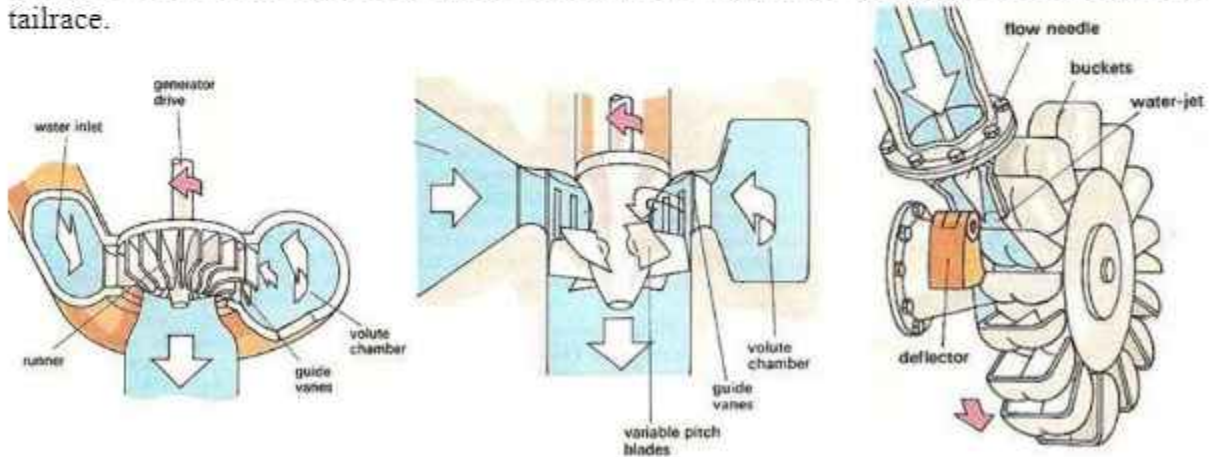

$$D_m = \text{Mean diameter, } D_m = \frac{D_0 + D_b}{2}$$

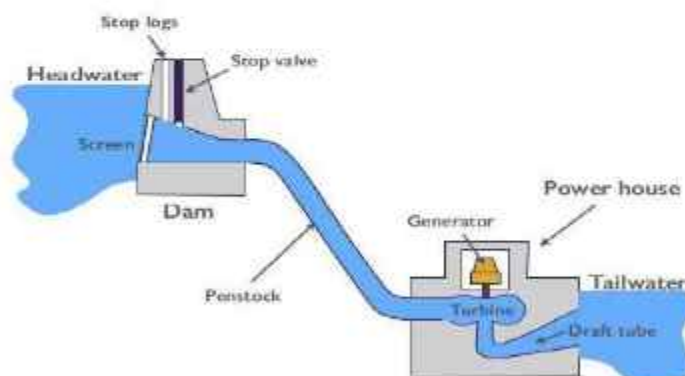

Types of Draft

Tube

Surge

Tanks

Surge tank (or surge chamber) is a device introduced within a hydropower water conveyance system having a rather long pressure conduit to absorb the excess pressure rise in case of a

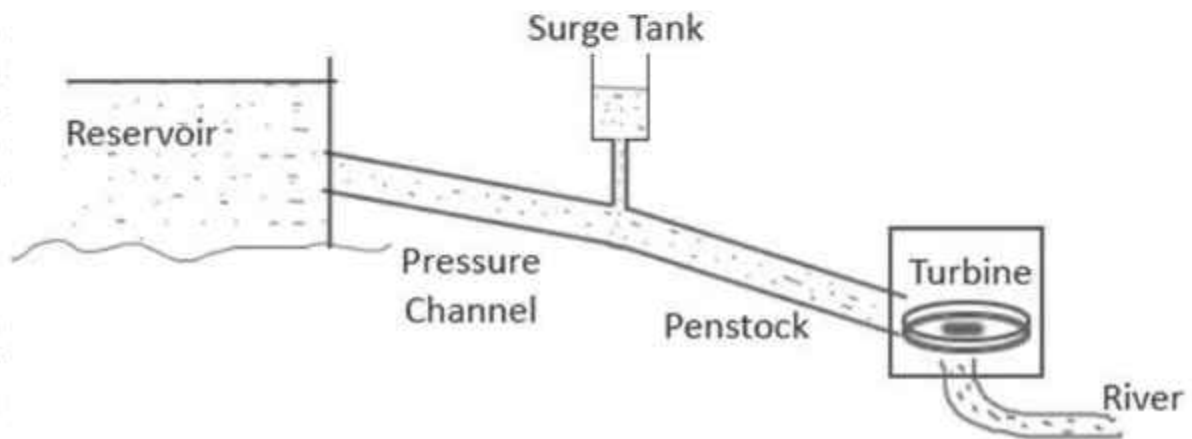

- a) Spear Regulation
- b) Deflector Regulation
- c) Combined

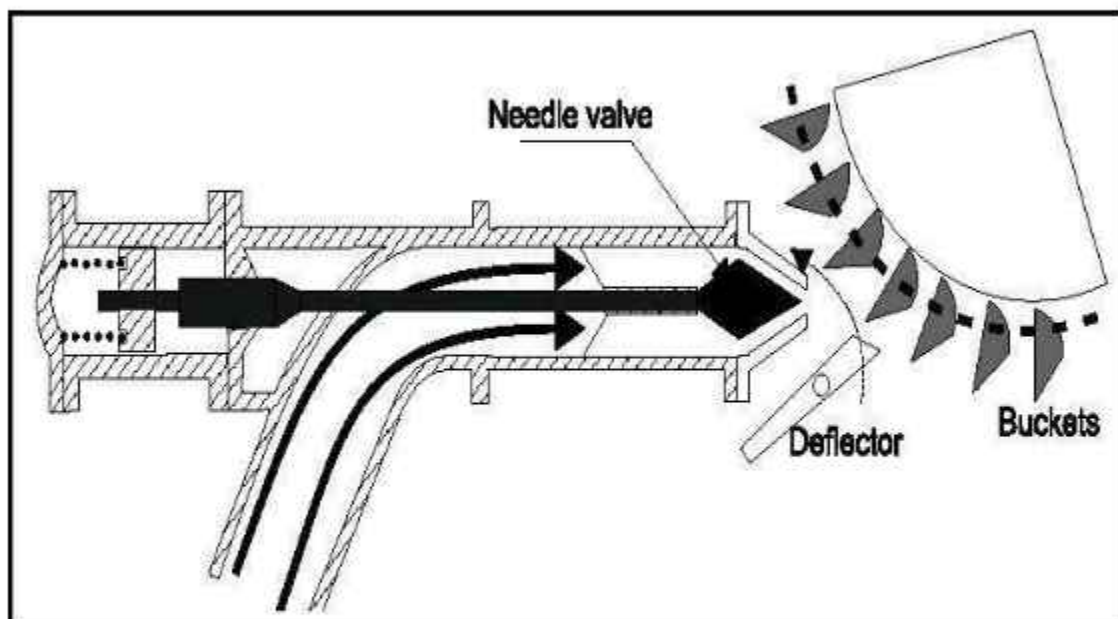

Performance of Turbines under unit quantities:

The unit quantities give the speed, discharge and power for a particular turbine under a head of 1m assuming the same efficiency. Unit quantities are used to predict the performance of turbine.

- Unit speed (N_u) - Speed of the turbine, working under unit head
- Unit power (P_u) - Power developed by a turbine, working under a unit head
- Unit discharge (Q_u) - The discharge of the turbine working under a unit head

$$\text{Specific speed} = N_u \frac{N}{\sqrt{H}}$$

$$\text{Unit power} = P_u = \frac{P}{\sqrt{H^3}}$$

$$\text{Unit discharge} = Q_u = \frac{Q}{\sqrt{H}}$$

Specific speed of the turbines (N_s):

The specific speed of the turbine is the speed at which the turbine will run when developing unit power under a unit head. This is the type characteristics of a turbine. For a set of geometrically similar turbines, the specific speed will have the same value. Mathematically, it can be shown as:

$$N \times \sqrt{P}$$

Specific speed = N_s

$$H^{5/4}$$

Characteristics Curves of Turbine:

These are curves which are characteristic of a particular turbine which helps in studying the performance of the turbine under various conditions. These curves pertaining to any turbine are supplied by its manufacturers based on actual tests. The characteristic curves obtained are the following:

- Constant head curves or main characteristic curves
- Constant speed curves or operating characteristic curves.

Constant efficiency curves

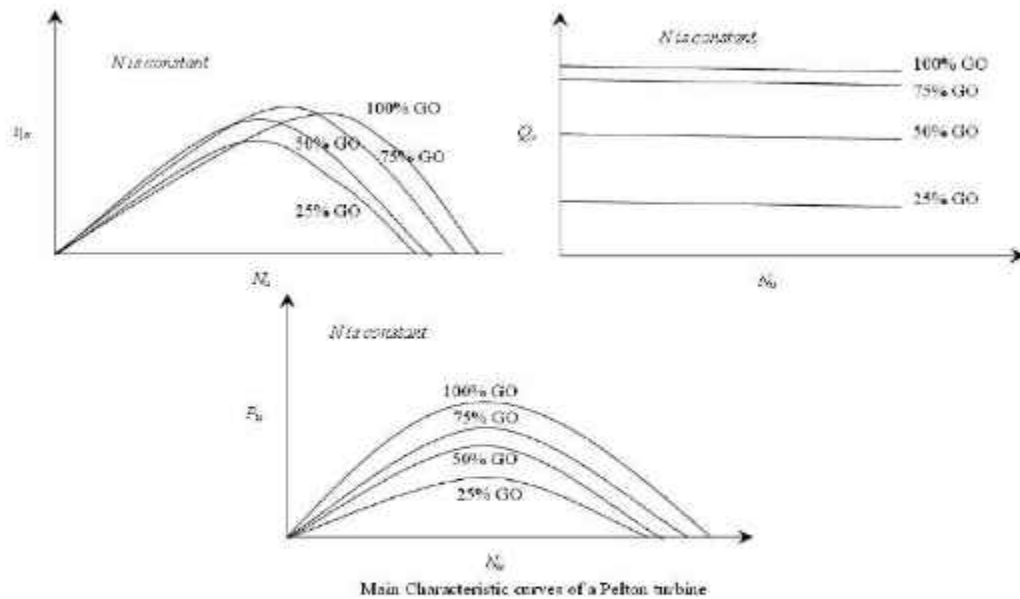

These curves are plotted from data which can be obtained from the constant head and constant speed curves. The object of obtaining this curve is to determine the zone of constant efficiency so that we can always run the turbine with maximum efficiency. This curve also gives a good idea about the performance of the turbine at various efficiencies.

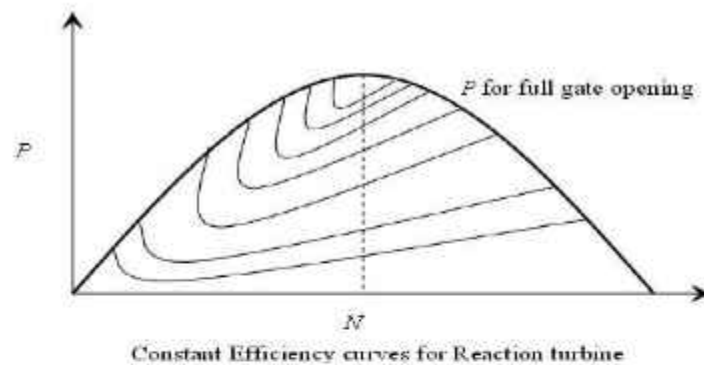

Constant speed curves or operating characteristic curves:

In this case tests are conducted at a constant speed varying the head H and suitably adjusting the discharge Q . The power developed P is measured mechanically. The overall efficiency is aimed at its maximum value. The curves drawn are between:

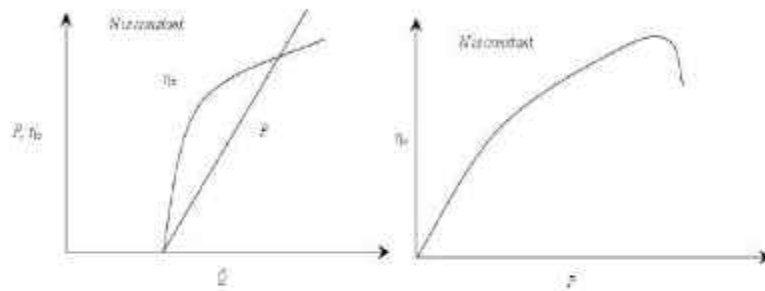

Cavitation:

If the pressure of a liquid in course of its flow becomes equal to its vapour pressure at the existing temperature, then the liquid starts boiling and the pockets of vapour are formed which create vapour locks to the flow and the flow is stopped. The phenomenon is known as cavitation.

To avoid cavitation, the minimum pressure in the passage of a liquid flow, should always be more than the vapour pressure of the liquid at the working temperature. In a reaction turbine, the point of minimum pressure is usually at the outlet end of the runner blades, i.e., at the inlet to the draft tube.

Methods to avoid Cavitation:

- (i) Runner/turbine may be kept under water.
- (ii) Cavitation free runner may be designed.
- (iii) By selecting materials that can resist better the cavitation effect.
- (iv) By polishing the surfaces.
- (v) By selecting a runner of proper specific speed for given load.

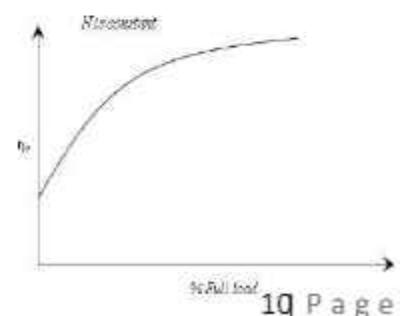

CENTRIFUGAL PUMPS

A pump is a hydraulic machine which converts mechanical energy into hydraulic energy or pressure energy. A centrifugal pump works on the principle of centrifugal force. In this type of pump, the liquid is subjected to whirling motion by the rotating impeller which is made of a number of backward curved vanes. The liquid enters this impeller at its centre or the eye and gets discharged into the casing enclosing the outer edge of the impeller. Generally centrifugal pumps are made of the **radial flow** type only ($\alpha = 90^\circ$).

Classification of Pumps

1. According to No. of Impellers
 - Single Stage Pump
 - Multistage Pump
2. According to Disposition of Shaft
 - Vertical Shaft Pump
 - Horizontal Pump
3. According to Head
 - Low Head Pump - $H < 15\text{m}$
 - Medium Head Pump - $15\text{m} < H < 40\text{m}$
 - High Specific Speed Turbine - $H > 40\text{m}$

A centrifugal pump containing two or more impellers is called a multistage centrifugal pump.

- For higher pressures at the outlet, impellers can be connected in series.
- For higher flow output, impellers can be connected parallel.

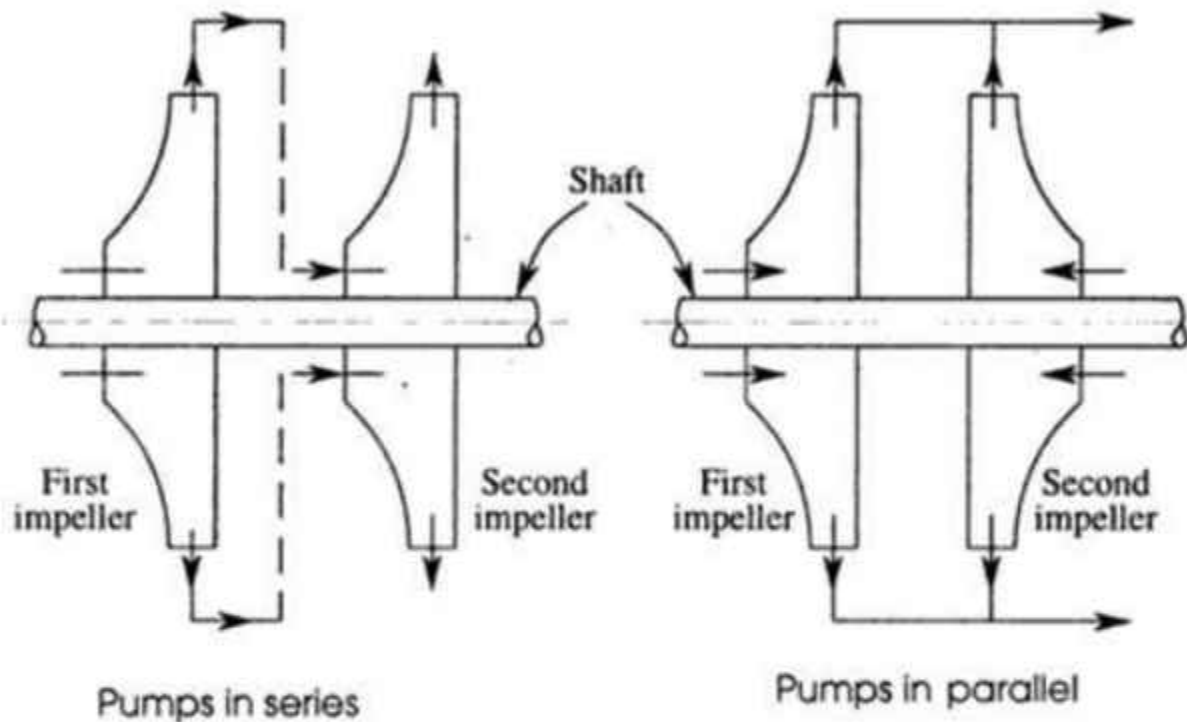

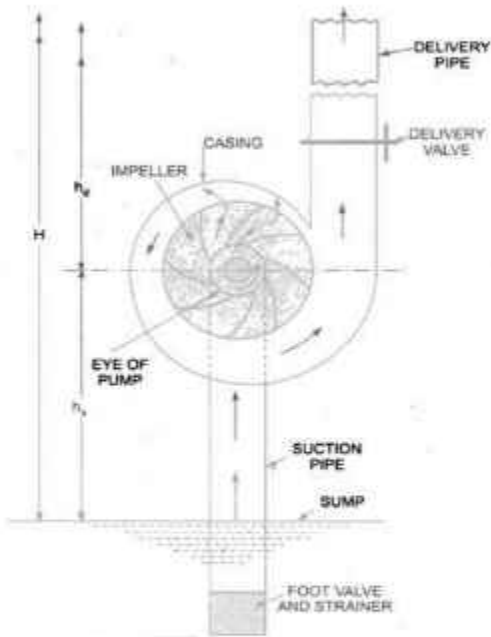

Main parts of a centrifugal pump.

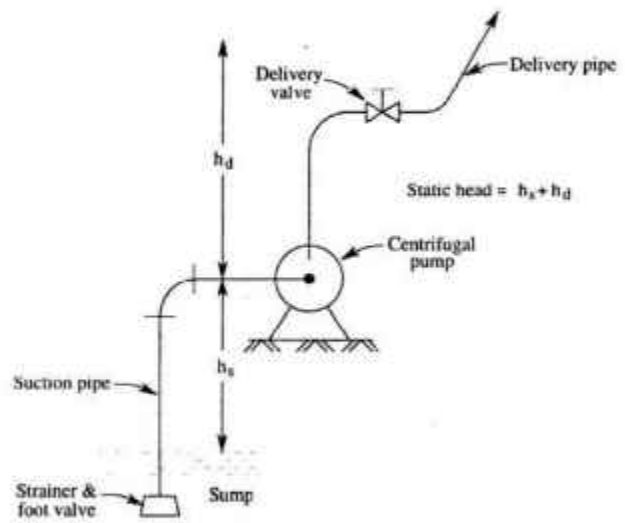

Components of Pump

1. Strainer and Foot Valve
2. Suction Pipe and its fittings
3. Pump
4. Delivery Valve
5. Delivery Pipe and its fittings

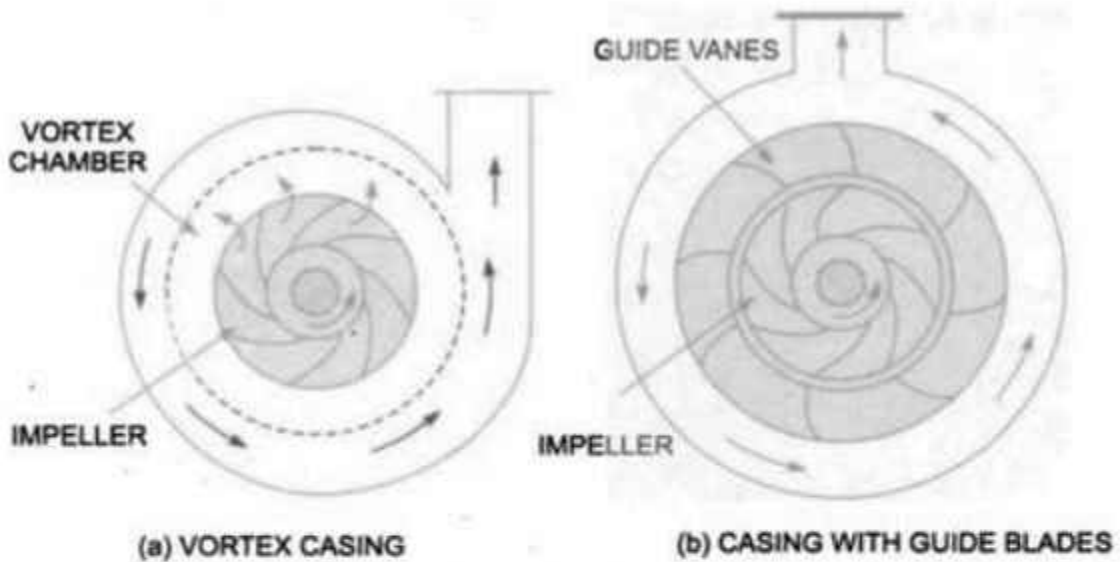

(a) VORTEX CASING

(b) CASING WITH GUIDE BLADES

Different types of casing.

Manometric Head:

It is the total head developed by the pump. This head is slightly less than the head generated by the impeller due to some losses in the pump.

$$H_m = \text{Suction Head} + \text{Delivery Head} + \text{Head Loss} + \text{Velocity Head in Delivery Pipe}$$
$$= h_s + h_d + h_f + V^2/2g$$

Manometric Efficiency:

$$\eta_{max} = \text{Manometric Head} / \text{Head Imparted by Impeller to Water}$$
$$= H_m / [(V_{w2} U_2) / g]$$
$$= g H_m / V_{w2} U_2$$

Head Imparted by Impeller to Water = Work done per Second

$$= Q(V_{w2} U_2)$$

Head Imparted by Impeller to Unit Weight of Water

= Work done per Second per Unit Weight of Water

$$= \frac{Q(V_{w2} U_2)}{mg}$$
$$= \frac{Q(V_{w2} U_2)}{(Q) g}$$
$$= \frac{V_{w2} U_2}{g}$$

Minimum Starting Speed of Pump:

A centrifugal pump will start delivering liquid only if the head developed by the impeller is more than the manometric head (H_m). If the head developed is less than H_m no discharge takes place although the impeller is rotating. When the impeller is rotating, the liquid in contact with the impeller is also rotating. This is a forced vortex, in which the increase in head in the impeller is given by

$$\text{Head rise in impeller} = \frac{u_2^2}{2g} - \frac{u_1^2}{2g}$$

Discharge takes place only when

$$\frac{u_2^2}{2g} - \frac{u_1^2}{2g} \geq H_m$$

substituting for u_1 , u_2 and H_m in Equation (10.13), we obtain

$$N = \frac{120\eta_m V_w D_2}{\pi(D_2^2 - D_1^2)}$$

which is the minimum speed for the pump to discharge liquid.

Specific Speed of Pump:

The specific speed of a centrifugal pump is defined as the speed of a geometrically similar pump which would deliver *one cubic metre* of liquid per second against a head of *one metre*. It is denoted by ' N_s '.

$$N_s = \frac{N\sqrt{Q}}{H_m^{3/4}}$$

Model Analysis of Pump:

Before manufacturing the large sized pumps, their models which are in complete similarity with the actual pumps (also called prototypes) are made. Tests are conducted on the models and performance of the prototypes are predicted. The complete similarity between the model and actual pump (prototype) will exist if the following conditions are satisfied :

1. Specific speed of model = Specific speed of prototype

$$(N_s)_m = (N_s)_p \quad \text{or} \quad \left(\frac{N\sqrt{Q}}{H_m^{3/4}} \right)_m = \left(\frac{N\sqrt{Q}}{H_m^{3/4}} \right)_p$$

Types of Reciprocating or displacement pumps:

- Piston pump
- Diaphragm pump
- Plunger pumps

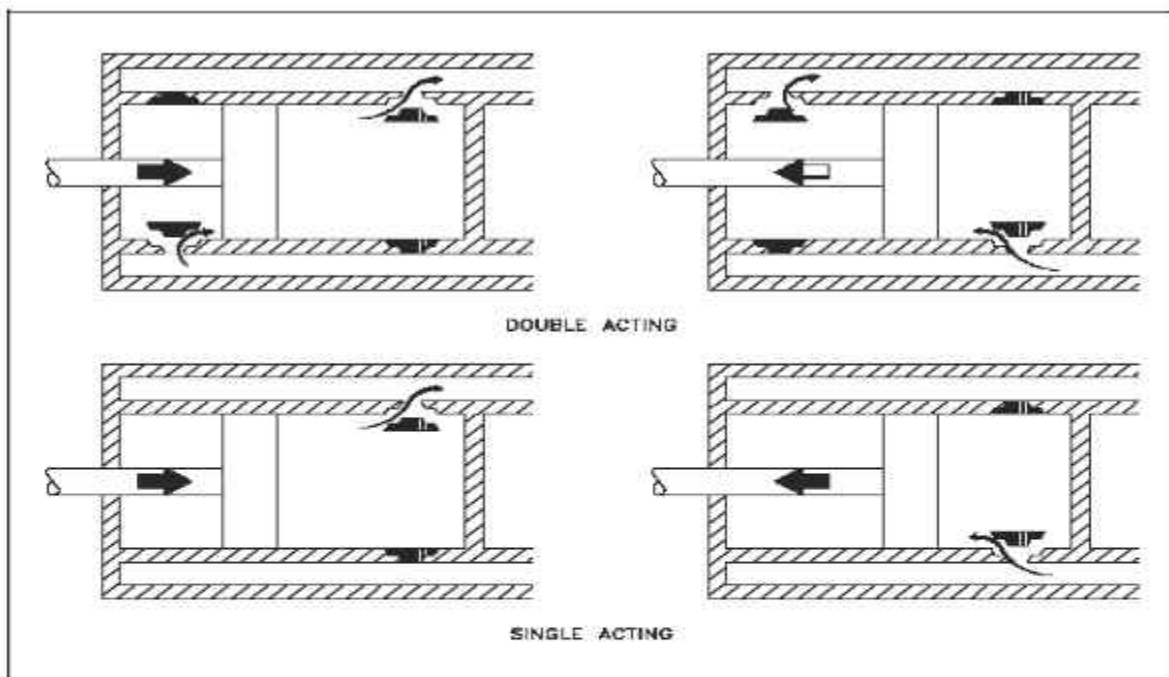
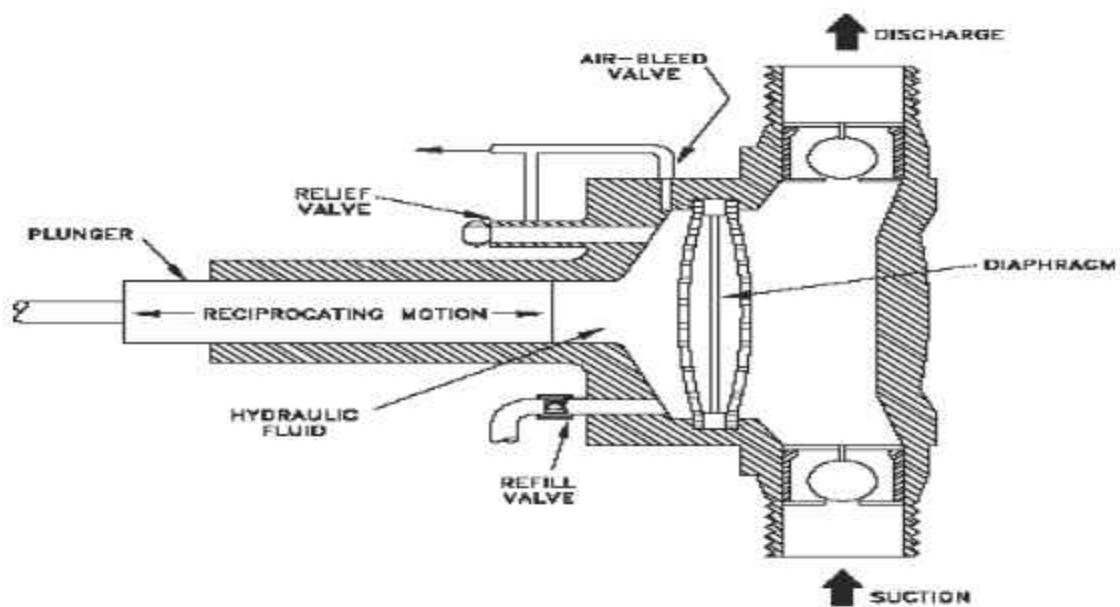
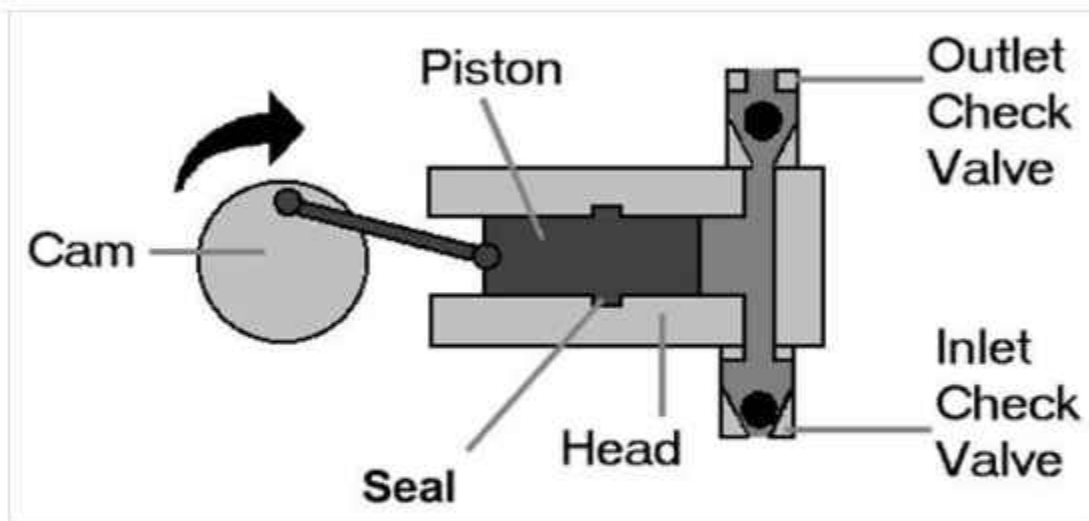

Figure 13 Single-Acting and Double-Acting Pumps



Major components of a reciprocating pump or displacement pump

- Piston or plunger
- Crank and Connecting rod
- Suction pipe
- Delivery pipe
- Suction and Delivery valve

Major terms used in reciprocating pump

- Brake Horsepower (B)
- Capacity(Q)
- Pressure (P_a)

Accumulator

An accumulator is a device which is used to store hydraulic energy inside a cylinder and released the same when required. It consists of a vertical cylinder containing a sliding ram. The inlet of cylinder is connected to the pump which continuously supply water under pressure to the cylinder. The outlet of the cylinder is connected to the machine.

At the beginning the ram is at the bottom position. When the pump supplies hydraulic fluid at high pressure and the fluid is not escaped to outlet, the ram begins to move upwards. The energy will be accumulated inside the cylinder continuously till the ram reaches at uppermost position. The same energy will be released when the outlet is connected to the machine.

Hydraulic Accumulator

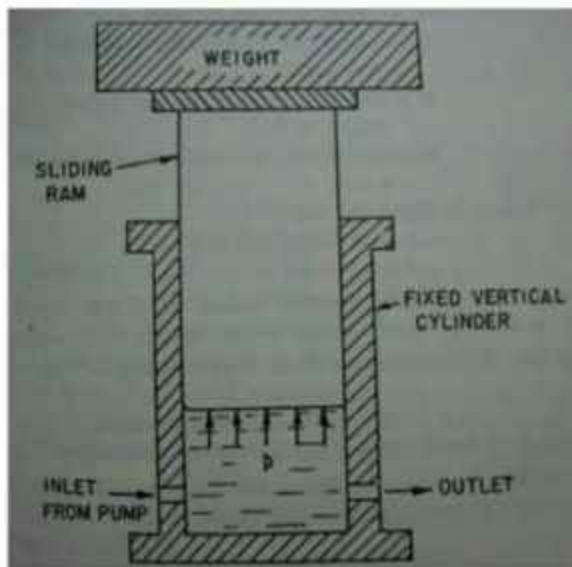

- Hydraulic accumulator consists of a fixed vertical cylinder containing a sliding ram.
- The heavy weight is placed on the ram.
- The inlet of the cylinder is connected to the pump which continuously supply water under pressure to the cylinder.
- Outlet of the cylinder is connected to the machine which may be a lift or a crane

Intensifier

A pressure intensifier is a device that is used to increase the pressure in a hydraulic circuit to a higher value, than that of provided by pump.

Principle of operation of Hydraulic Intensifier:

It takes the high volume, low-pressure flow from the pump and converts a portion of this flow to a required value of high pressure. A pressure intensifier is analogous to a step-up transformer in electrical power transmission, which receives, low voltage and high current and converts it into high voltage and low current.

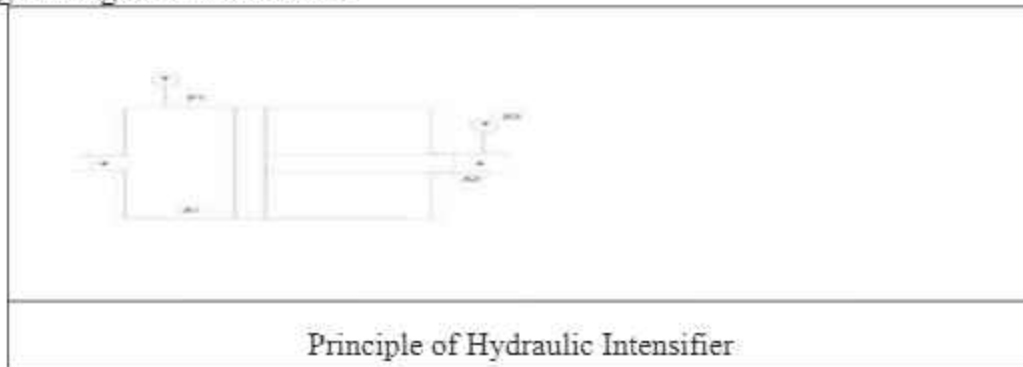

Pressure intensifier does not change the power, but changes the form of the power i.e. from low-pressure high volume to high-pressure low volume. Neglecting the losses, the pressure-flow product at the inlet to intensifier is the same as the pressure-flow product at the outlet.

Types of Intensifiers

Depending upon the construction and working medium the following types of intensifiers are used.

1. Single-acting intensifier
2. Double-acting intensifier
3. Air Oil intensifier

Hydraulic lift

A hydraulic lift is a device for moving objects using force created by pressure on a liquid inside a cylinder that moves a piston upward. Incompressible oil is pumped into the cylinder, which forces the piston upward. When a valve opens to release the oil, the piston lowers by gravitational force.

The principle for hydraulic lifts is based on Pascal's law for generating force or motion, which states that pressure change on an incompressible liquid in a confined space is passed equally throughout the liquid in all directions.

The concept of Pascal 's law and its application to hydraulics can be seen in the example below, where a small amount of force is applied to an incompressible liquid on the left to create a large amount of force on the right.



Hydraulic systems are used for precision control of large force applications, are economical, and make excellent use of energy resources.

Hydraulic Ram

A hydraulic ram is a cyclic water pump powered by hydropower. It functions as a hydraulic transformer.

It is a device which raises small quantity of water without any external power to higher level from large quantity of water available at lower level.

CONSTRUCTIONAL DETAILS

- The main part of hydraulic ram are listed below:

- a) Supply tank
- b) Supply pipe
- c) Valve chamber
- d) Waste valve
- e) Delivery valve
- f) Air vessel
- g) Delivery pipe
- h) Delivery tank



WORKING

- Hydraulic ram works on the principal of water hammer as when a flowing water is suddenly brought to rest the change in momentum of water masses causes a sudden rise in pressure. This rise in pressure is utilized to raise a small quantity of water to higher level.
- Initially, the waste valve is open and delivery valve is closed. The water from supply tank start to flow under the force of gravity and picks up speed and kinetic energy until it forces the waste valve closed.
- The momentum of the water flow in supply pipe against now closed waste valve causes a water hammer that raises the pressure in chamber. The high pressure of water opens the delivery valve and water enters into the air vessel which further compresses the air already present in the air vessel.

- The pressure in the air vessel raises which closes the delivery valve, now water from air vessel is forced to flow through delivery pipe.
- Under this condition waste valve and delivery valve both remains closed
- Slowly pressure in the valve chamber falls and waste valve again opens allowing the water to flow through it.
- Now, under this condition, flow through the supply pipe begins again producing water hammer in the valve chamber. The cycle is repeated.

PROCESS



DIAGRAM

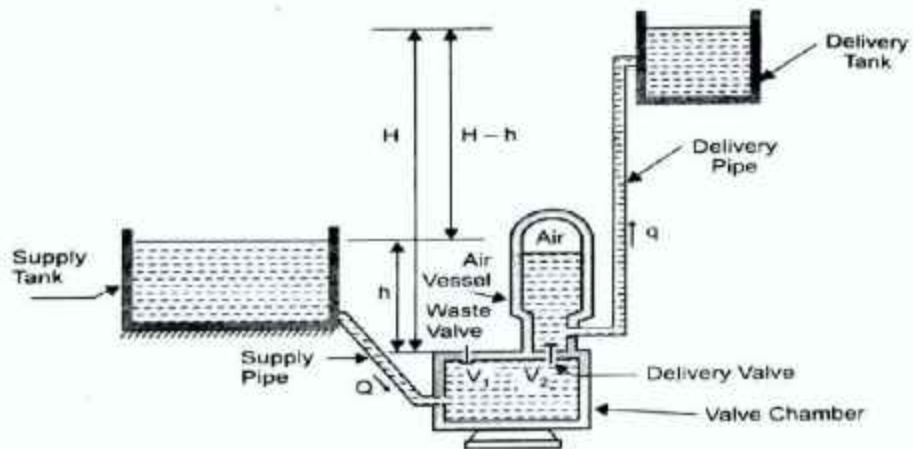

Fig. Hydraulic ram

SOME IMPORTANT FEATURE OF A HYDRAULIC RAM (ADVANTAGES)

1. No prime mover is required because it runs it self.
2. Simple design
3. Low repair cost
4. Negligible running cost
5. No electricity consumption
6. It work continuously and, therefore gives regular supply
7. Long life
8. Reliable.

DISADVANTAGES

1. Large amount of water wasted through waste valve.
2. Its working is noisy.
3. Only suitable for certain sites.

APPLICATION

- To lift the drinking water from spring to high ground settlement.
- Use where flowing water is available.
- It is useful in “hilly area” where large quantity of water flows at low level is needed to be raised for domestic or irrigation purposes.

PNEUMATIC SYSTEM:

Pneumatic System:

Pneumatic technology deals with the study of behavior and applications of compressed air in our daily life in general and manufacturing automation in particular. Pneumatic systems use air as the medium which is abundantly available and can be exhausted into the atmosphere after completion of the assigned task.

☞ Pneumatic power unit

☞ Fig shows the circuit for pneumatic power unit.

☞ In this air compressor compresses the air which is then stored in the receiver. This air is further pass in the system through FRL unit.

☞ The FRL unit **filter** the air, **regulates** the pressure in the system and also **lubricates** the air.

Filters

To prevent any damage to the compressor, the contaminants present in the air need to be filtered out. This is done by using inlet filters. These can be dry or wet filters. Dry filters use disposable cartridges. In the wet filter, the incoming air is passed through an oil bath and then through a fine wire mesh filter. Dirt particles cling to the oil drops during bubbling and are removed by wire mesh as they pass through it. In the dry filter the cartridges are replaced during servicing. The wet filters are cleaned using detergent solution.

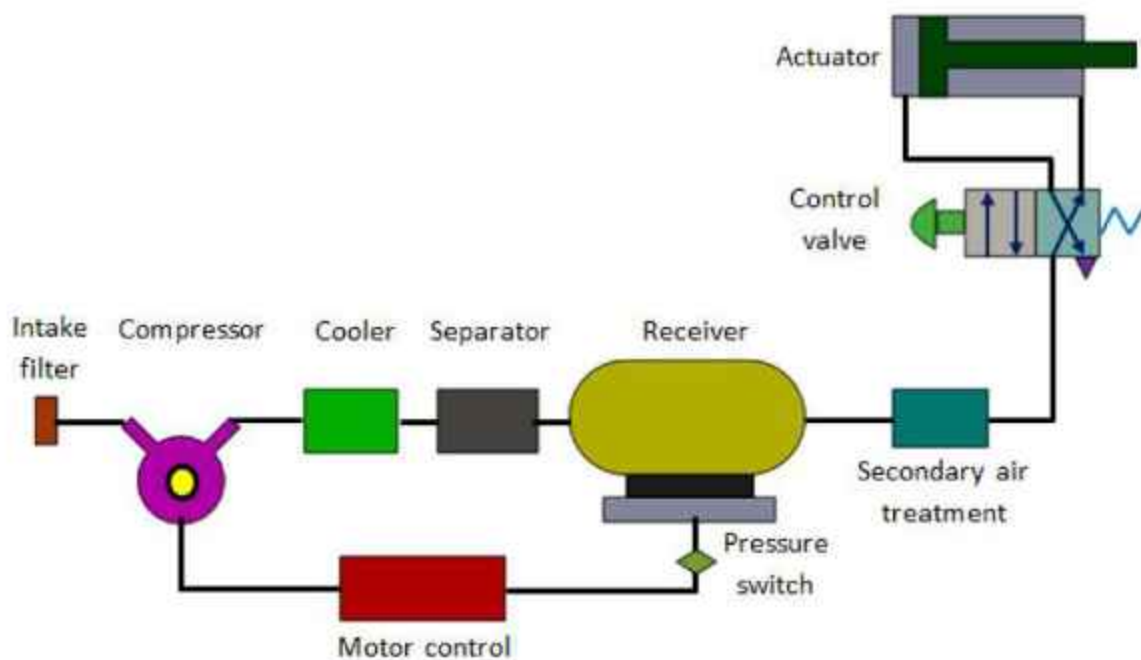

A pneumatic filter should be the first component at the inlet of most air circuits. This unit usually is one part of a combination of components that filters the air, regulates its pressure, and adds lubricants for moving parts in the circuit. The air filter and lubricator are covered in this section. (An air line regulator performs the same function as a hydraulic reducing valve and is covered in that section.)

- Air from the compressor contains dust from the ambient atmosphere, condensed water, and rust and oil sludge that bypass the compressor rings. These by-products of compressing and transmitting air must be removed to keep moving parts of the machine working properly. Most filters clean the air and separate condensed water from it before the air enters the circuit.

Pneumatic filter

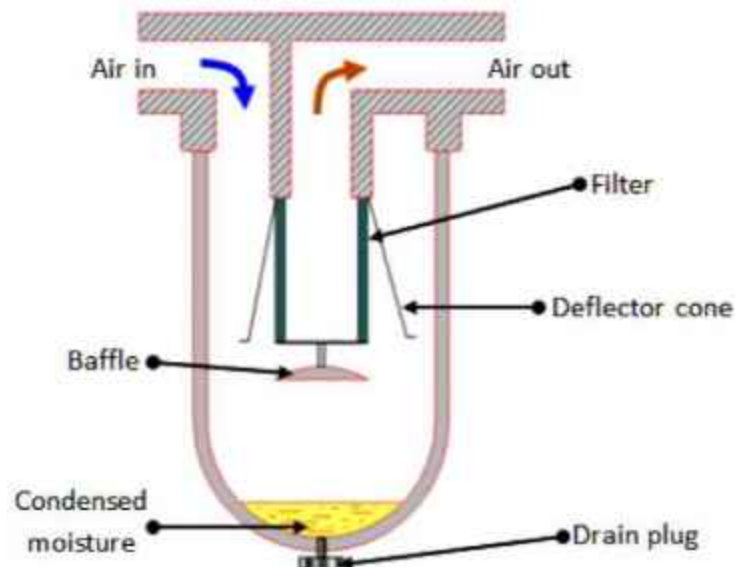

- **PRESSURE REGULATORS**

- Air pressure regulators benefit the FRL box set in many ways. Firstly, and most importantly it provides an element of safety. Subsequent to this, it also helps to reduce costs. The role of a regulator is to control the air pressure to air tools, air gauging equipment and cylinders. The air pressure is regulated by a spring which acts through a diaphragm.

- **Pressure regulator valve.**
- A pressure regulator is a device which controls the pressure of liquids or gases (medium) by reducing a high input pressure to a controlled lower output pressure. They also work to maintain a constant output pressure even when there are fluctuations in the inlet pressure.
- **Pressure reducing element**
- Spring loaded poppet valves are commonly used as a pressure reducing element. Poppet valves have elastomeric sealing in regular applications and a thermoplastic sealing in high pressure applications. This seals the valve seating against any gas or fluid leakage. The poppet valve is controlled by the spring force to open the valve and let the medium flow from inlet to outlet. As there is a rise in output pressure, the poppet valve closes due to the force generated by the sensing element, which overcomes the spring force

Pressure regulator valve

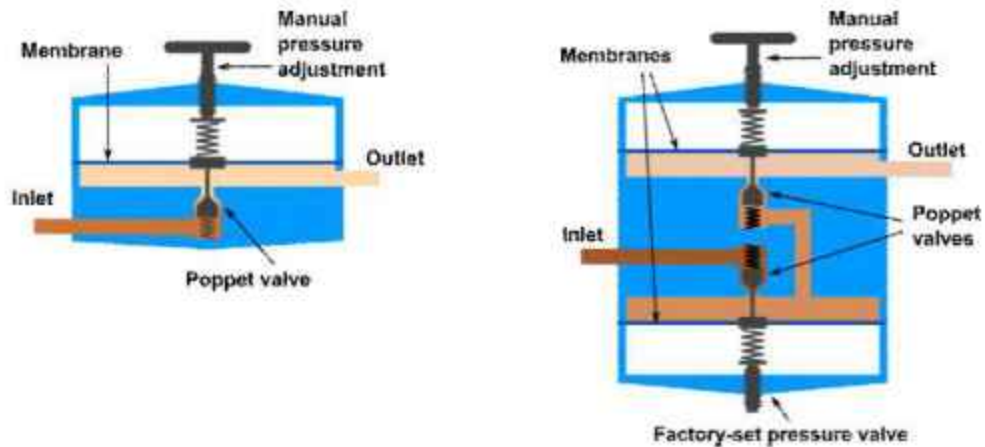

Basic elements of a pressure regulator

- A typical pressure regular consists of the following elements:
- A pressure reducing element such as a poppet valve.
- A loading element to apply necessary force to the reducing element such as a spring, piston actuator or a diaphragm actuator.
- A sensing element such as a diaphragm or a piston.

- **Types of pressure regulators**
- Pressure regulators can be broadly classified into the following categories:
 - Direct Operated or Self-operated
 - Pilot operated
- **Direct operated regulators**
 - They are the simplest form of regulators (Fig. 1). They normally operate at lower set pressures, below 0,07 bar (1 psi) and can have greater accuracy. At higher pressures, up to 35 bar (500 psi), they can have 10-20% accuracy levels.
- **Pilot operated regulators**
 - These regulators are ideal for applications with large variation in flow rates, fluctuations in inlet pressure, or decreasing inlet pressure conditions that normally occur with gas supplied in cylinders or small storage tanks. It provides precise pressure control.
 - This type of regulator is generally a one or two stage device. **A single-stage regulator** is ideal for relatively small reduction in pressure. They are not suitable where

there are large fluctuations in inlet pressure or flow rates.

Lubricator

Figure below shows a cutaway view of an air-line lubricator. After the combination unit filters and regulates air pressure, some downstream system components may require a small amount of lubrication. (For example: air motors are one item that needs a constant supply of oil to extend their life and maintain torque.) Some cylinders are pre-lubed and most valves require little if any lubrication, so keep oil supply to these units at minimum. A general rule: a ½-pint bowl of oil in a lubricator should last three weeks to a month in most situations.

When air passes through the lubricator's venturi section, pressure drop across it gives a negative pressure in the area below the adjustable orifice. Vacuum in this area draws oil from the bowl as fast as the adjustable orifice will allow. These droplets then mix with the air as it passes through. This arrangement means that oil flows only when there is air flow and only as fast as the adjusting screw allows.

Lubricator

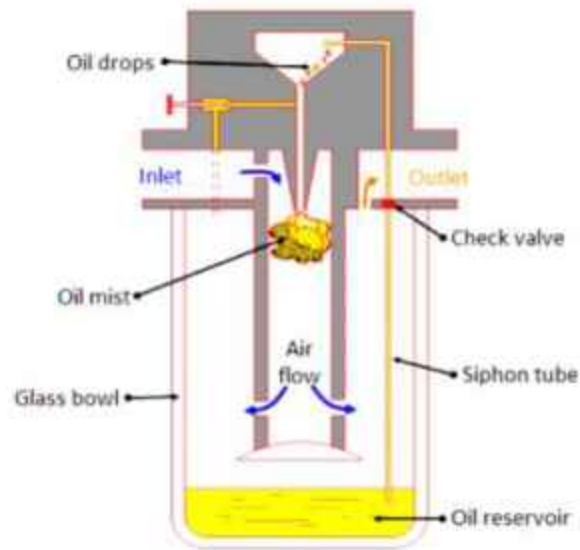

Pressure relief valve.

The pressure relief valves are used to protect the system components from excessive pressure. Its primary function is to limit the system pressure within a specified range. It is normally a closed type and it opens when the pressure exceeds a specified maximum value by diverting pump flow back to the tank.

The simplest type valve contains a poppet held in a seat against the spring force as shown in Figure. This type of valves has two ports; one of which is connected to the pump and another is connected to the tank. The fluid enters from the opposite side of the poppet. When the system pressure

exceeds the preset value, the poppet lifts and the fluid is escaped through the orifice to the storage tank directly. It reduces the system pressure and as the pressure reduces to the set limit again the valve closes.

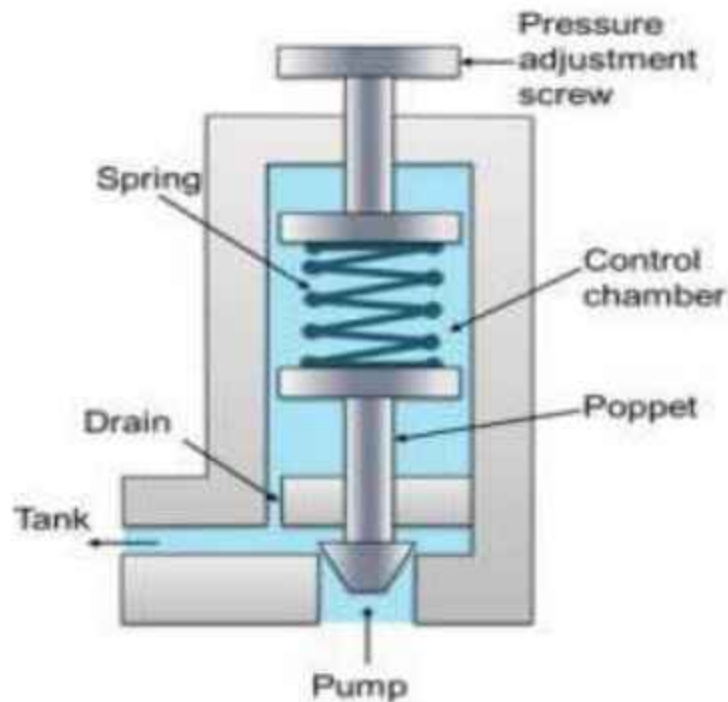

Directional Control Valve

- Directional control valves are used in pneumatic systems to direct or stop the flow of compressed air or oil to their appliances. They are probably the most used elements in pneumatic systems and can be used for example to actuate a cylinder, a larger industrial valve,

or air tools. The valves can have two or more ports and fulfil various circuit functions.

- Valve types
- Directional valves are appointed with two numbers. The first number shows how many ports the valve has, and the second number is the amount of states. For example, a 2/2-way valve has two ports (in/out) and two states (open/closed). A 5/2-way valve has five ports and two states. Directional valves usually have two, three, or five ports. In the following sections, the different types will be explained in more detail.
- 3/2-way valve
- 5/2-way valve
- 5/3-way valve
- 3/2-way valve
- A 3/2-way valve has three ports and two states. They are used for instance to control a single-acting cylinder. The valve is used to fill the cylinder, but also to vent the cylinder afterward to realize a new working stroke. Therefore, a valve with two ports would not be sufficient. A third port is required for venting. 3/2-way valves can be

mono-stable or bi-stable. Just like 2/2-way valves, mono-stable 3/2-way valves can be normally closed or normally open. The symbol below represents a mono-stable 3/2-way that is normally closed.

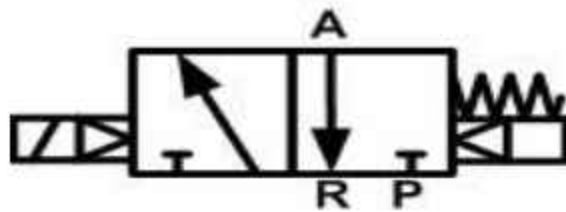

- 5/2-way valve
- A 5/2-way valve has five ports and two states. These valves are used for instance to control double acting cylinders. A double acting cylinder requires two outlet ports of the valve. 5/2-way valves can be mono-stable or bi-stable.



5/2-way valve

5/2-way valves are used to actuate double acting pneumatic actuators, such as pneumatic cylinders, rod less cylinders, grippers and rotary actuators. Double acting actuators require compressed air to move in both directions. To decide whether a mono-stable or bi-stable 5/2-way valve should be applied, it is necessary to know more about the system's design and requirements.

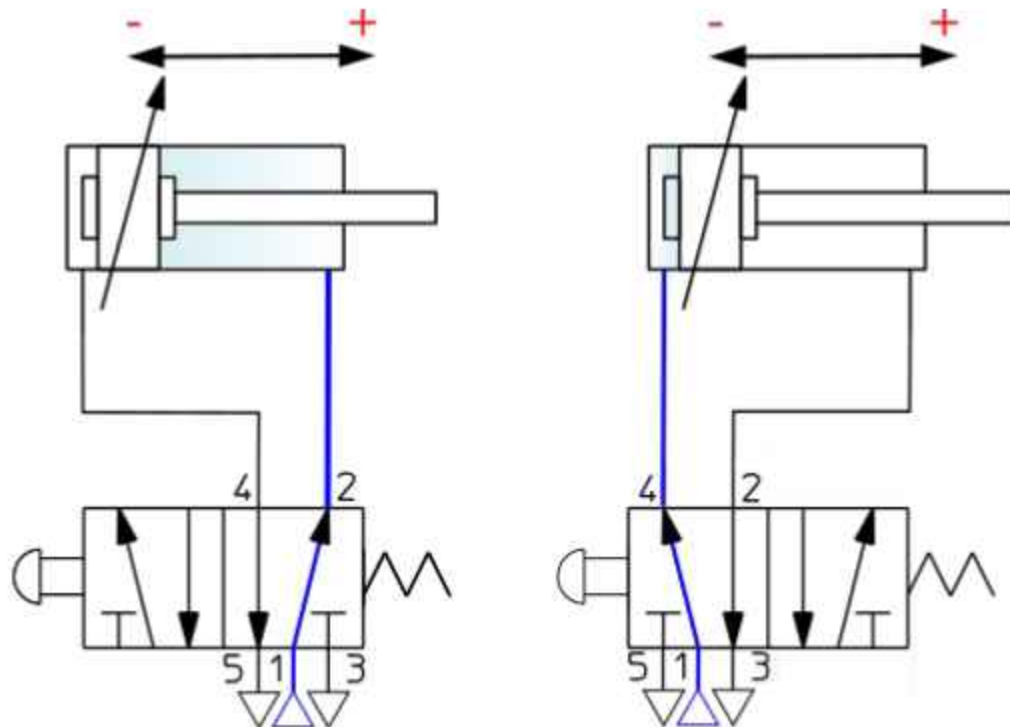

5/3-way valve

The before mentioned valves all have two states. It is also possible to have a third state, for example, a 5/3-way solenoid valve. The third state is used to stop a double acting cylinder in an intermediate position. These valves are mono stable and return to the centre position when the solenoids are not energized. Two solenoids are used to switch the valve to the other two states. 5/3 valves are available in three variants; with closed centre position, with venting centre position and with the pressurized centre position. The closed centre valve is represented by the symbol shown below.

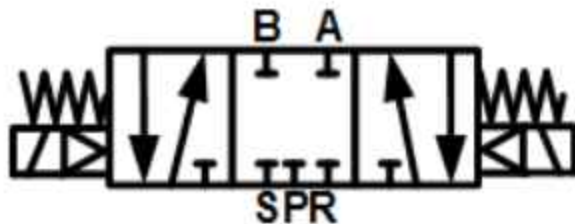

Pneumatics Symbols

DIN ISO1219-1, 03/96. Graphic symbols for pneumatic equipment.

Circuit symbols are used through this catalogue and on the labels of most SMC Pneumatic products.

There are several symbol systems and conventions in use around the world, most officially recognised by standards bodies. Commonly used is ISO1219-1.

The symbols found in this catalogue generally conform to the Japanese Industrial Standard (JIS) in many cases, there is no difference between JIS and ISO circuit symbols.

The situation also occurs when SMC develop new product systems for which an ISO or JIS symbol does not exist. Examples include the MGZ high power cylinder or the AV series air operated soft start / release valve. In this situation either a composite symbol showing a representative circuit is used, or the nearest standard symbol is modified by SMC.

For assistance a table below shows both ISO symbols, which may differ from JIS symbols in this catalogue, and common ISO/JIS/SMC Symbols.

Volume 1



Symbol	Description
	Directional control valve 2/2-way valve, closed normal position
	Directional control valve 2/2-way valve, open normal position
	Directional control valve 3/2-way valve, closed normal position
	Directional control valve 3/2-way valve, open normal position
	Directional control valve 3/3-way valve, closed neutral position
	Directional control valve 4/2-way valve
	Directional control valve 4/3-way valve, closed neutral position
	Directional control valve 4/3-way valve, exhaust neutral position
	Directional control valve 5/2-way valve
	Directional control valve 5/3-way valve, closed neutral position

Symbol	Description
	Directional control valve 5/3-way valve, exhaust neutral position
	Directional control valve 5/3-way valve, open neutral position
	Manual Control General
	Manual Control Button
	Manual Control Lever
	Manual Control Pedal
	Mechanical Control Plunger
	Mechanical Control Spring
	Mechanical Control Roller
	Mechanical Control Roller with idle return
	Solenoid with one effective winding
	Solenoid with two windings acting in opposition
	Combined Control by solenoid and pilot valve
	Pressure Control
	Shuttle valve
	Pneumatic- Electric-Relay
	Pneumatic indicator
	Blender
	Pressure Control Valve Air operated
	Mechanical Component Defeat

- **Flow control valve.**
- **The purpose of flow control in a hydraulic system is to regulate speed. All the devices discussed here control the speed of an actuator by regulating the flow rate. Flow rate also determines rate of energy transfer at any given pressure. The two are related in that the actuator force multiplied by the distance through which it moves (stroke) equals the work done on the load. The energy transferred must also equal the work done. Actuator speed determines the rate of energy transfer (i.e., horsepower), and speed is thus a function of flow rate.**

Orifices — A simple orifice in the line, Figure (a), is the most elementary method for controlling flow. When used to control flow, the orifice is placed in series with the pump. An orifice can be a drilled hole in a fitting, in which case it is fixed; or it may be a calibrated needle valve, in which case it functions as a variable orifice, Figure (b). Both types are non-compensated flow-control devices.

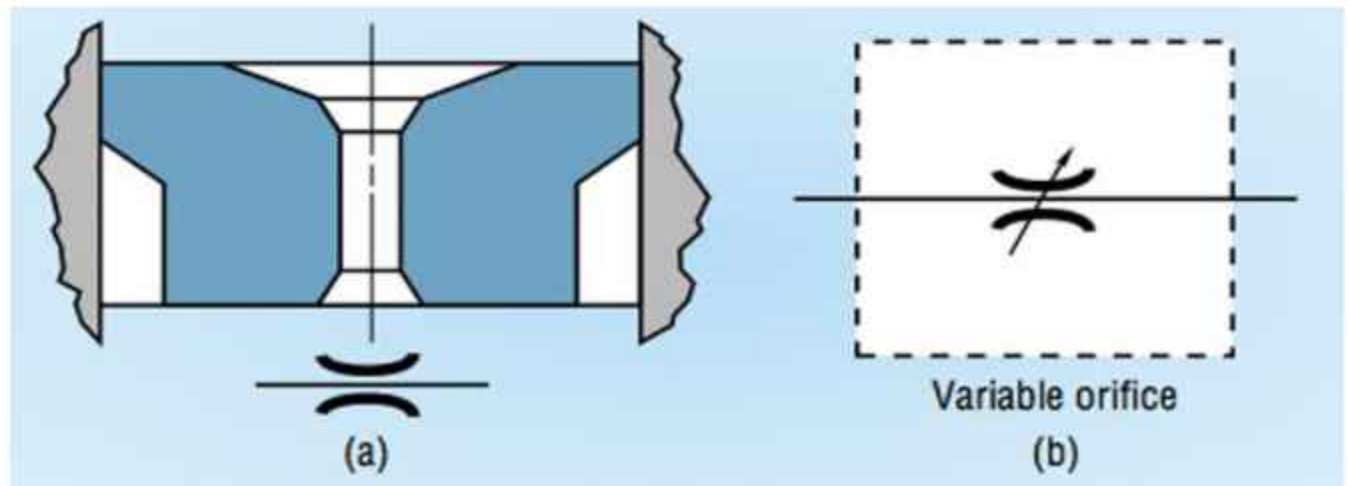

- **THROTTLE VALVE**

- In general, throttles should be installed in the outlet side, so that the slipping is reduced. When using double-acting cylinders, there are two options: Either throttle check valves in the inlet side or simple throttles mounted right on the vent connexions of the valve . The latter is mainly used in valve terminals.
- With single-acting cylinders remains only the possibility to install the throttle in the inlet side. However, since this also is the outlet side while the cylinder is retracting, a throttle check valve is to be used.

SPEED CONTROL CIRCUITS

- 1. Meter-in speed control pneumatic circuit:

- Fig shows the speed control pneumatic circuit.
- It consist of manually operated D.C. valve, a flow control valve.
- A flow control valve is placed in the pressure line such that the air flow rate is regulated as the air enters the blank end of double acting cylinder to perform forward stroke.
- When the spool is shifted to its left envelop mode the air from FRL unit is directed to enter the blank end of cylinder through flow control valve where the air flow rate is controlled to control the forward stroke of piston in the cylinder.
- The air from the other side of piston is discharged out into the atmosphere.

When the spool is shifted to right envelop mode the air enters the rod end of cylinder and acts on

- piston to perform return stroke quickly. The air from other side of piston discharged out freely into the atmosphere through the check valve .

Meter-in speed control pneumatic circuit

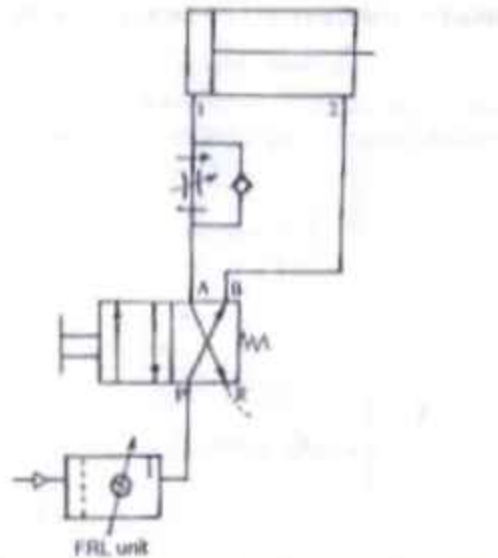

Pneumatic circuit used for meter-in applications

- **METER-OUT SPEED CONTROL PNEUMATIC CIRCUIT:**
- It uses the flow control valve to control the rate of piston movement on the outstroke of machine
- It consist of pneumatic power unit, manually operated D.C. valve, flow control valve
- When spool is in its left envelop mode the air from FRL unit enters the blind end of cylinder
- and acts on the piston to perform forward stroke.

- The air from other end of cylinder is allowed to pass through a flow control valve to regulate the outstroke speed of piston.
- When the spool is in right envelop mode, the piston retracts quickly.

Pneumatic circuit to control the speed of double acting

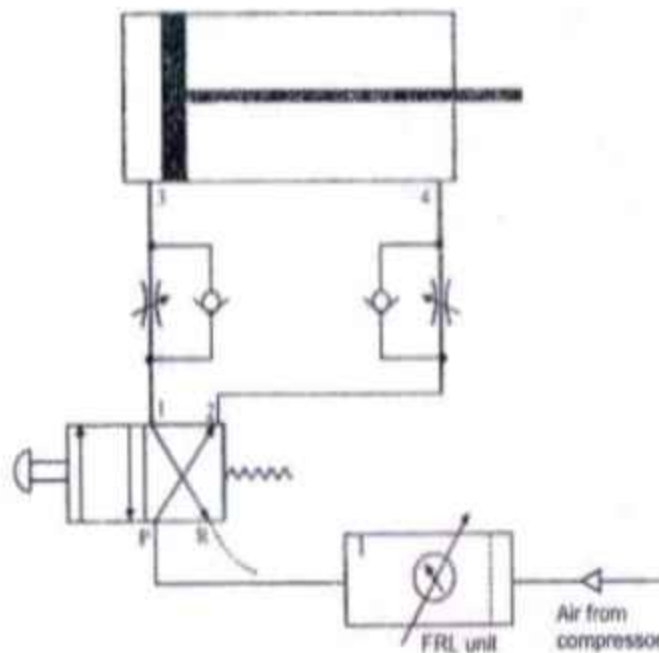

Pneumatic circuit to operate double acting cylinder :

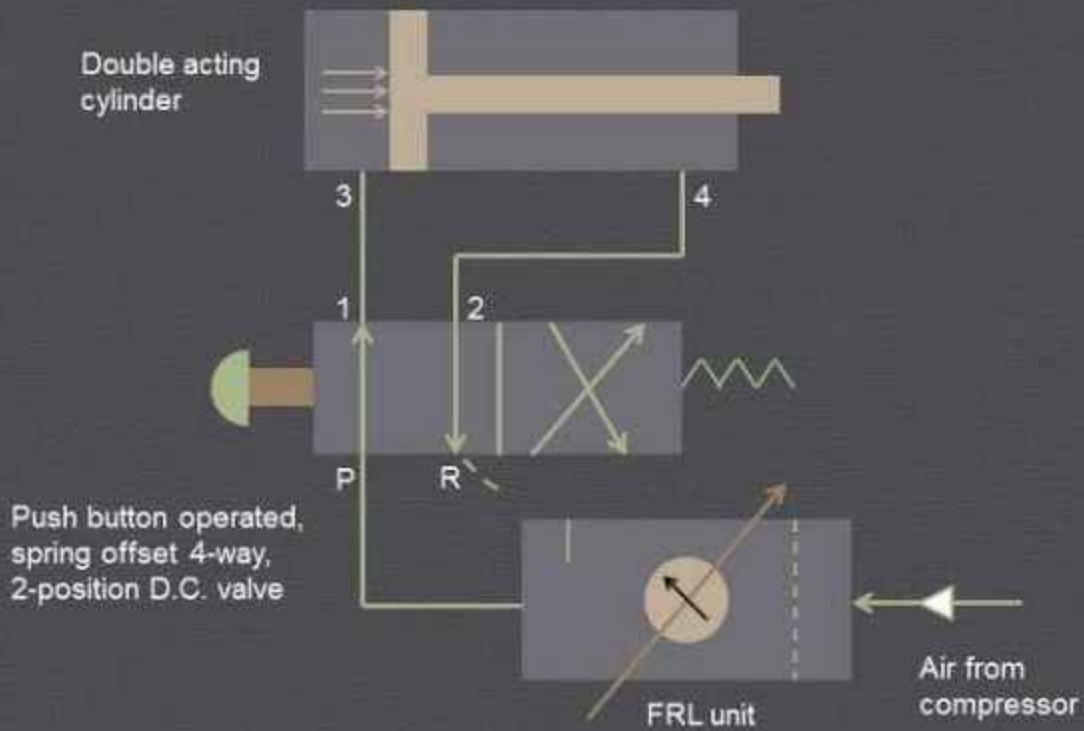

- **FLUID POWER.**

Definition.

Fluid power is the technology that deals with the generation, control and transmission of forces and movement with the use of pressurized fluids in a confined system.

MERITS OF HYDRAULIC SYSTEM.

- 1. Large load capacity with almost high accuracy and precision.**
- 2. Smooth movement.**
- 3. Automatic lubricating provision to reduce wear.**
- 4. Division and distribution of hydraulic forces are easily performed.**
- 5. Limiting and balancing of hydraulic forces are easily performed.**

DEMERITS OF HYDRAULIC SYSTEM.

- 1. A hydraulic element needs to be machined to a high degree of precision.**
- 2. Leakage of hydraulic oil poses a problem to hydraulic operators.**
- 3. Special treatment is needed to protect them from rust, corrosion, dirt etc.,**

4. Hydraulic oil may pose problems if it disintegrates due to aging and chemical deterioration.

5. Hydraulic oils are messy and almost highly flammable.

ACCUMULATOR

An accumulator is a device which is used to store hydraulic energy inside its cylinder and released the same when required. It consist of a vertical cylinder containing a sliding ram. The inlet of cylinder is connected to the pump which continuously supplies water under pressure to the cylinder. The outlet of the cylinder is connected to the machine(may be lift or crane etc.)

At the beginning the ram was at bottom position. When the pump supplies hydraulic fluid at high pressure and the fluid is not escaped to outlet, the ram begins to move upward. The energy will be accumulated inside the cylinder continuously till the ram reaches at uppermost position. The same energy will be released when the out let is connected to the machines.

Accumulator

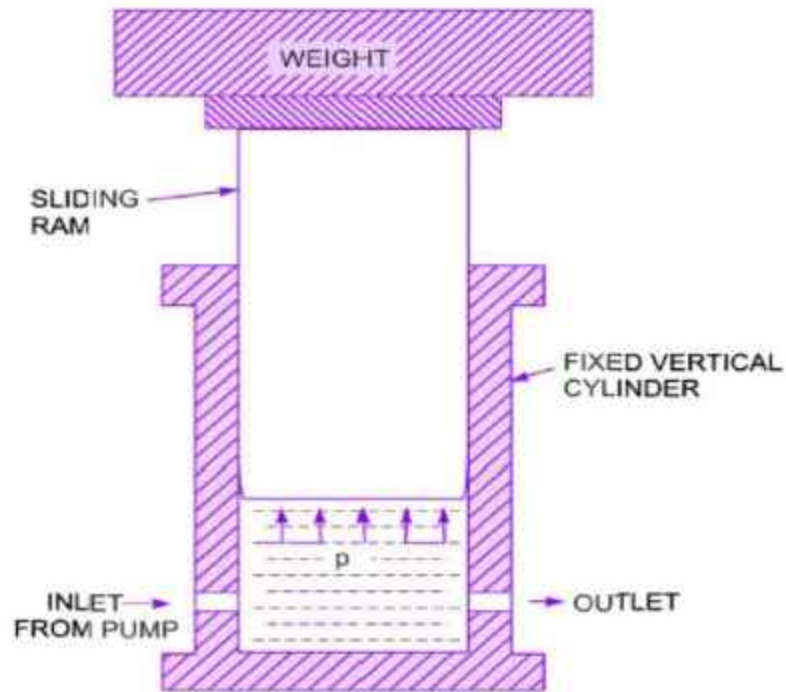

Capacity of accumulator.

Let,

P=Intensity of pressure inside the cylinder.

A=Cross sectional area of ram.

L= Lift or stroke of ram.

W= Applied dead weight including self weight of ram.

$$W = p \times A$$

$$\text{Work done} = p \times A \times L$$

Work done = stored energy inside the cylinder = Capacity of accumulator.

Capacity of accumulator = $p \times A \times L$

HYDRAULIC ACTUATOR

Hydraulic actuator consists of a cylinder, piston, spring, hydraulic supply, return line, and stem. The piston slides vertically inside the cylinder and separates the cylinder into two chambers. The upper chamber contains the spring and the lower chamber contains hydraulic oil. The hydraulic supply and return line is connected to the lower chamber.

When the fluid enters the lower chamber, pressure in the chamber increases and pushes the piston in upward direction. When the hydraulic force is greater than the spring force, the piston begins to move upward, the spring compresses, and the valve begins to open.

As the hydraulic pressure increases, the valve continues to open. Conversely, as hydraulic oil is drained from the cylinder, the hydraulic force becomes less than the spring force, the piston moves downward, and the valve closes. By regulating amount of oil supplied or drained from the actuator, the valve can be positioned between fully open and fully closed.

HYDRAULIC ACTUATOR

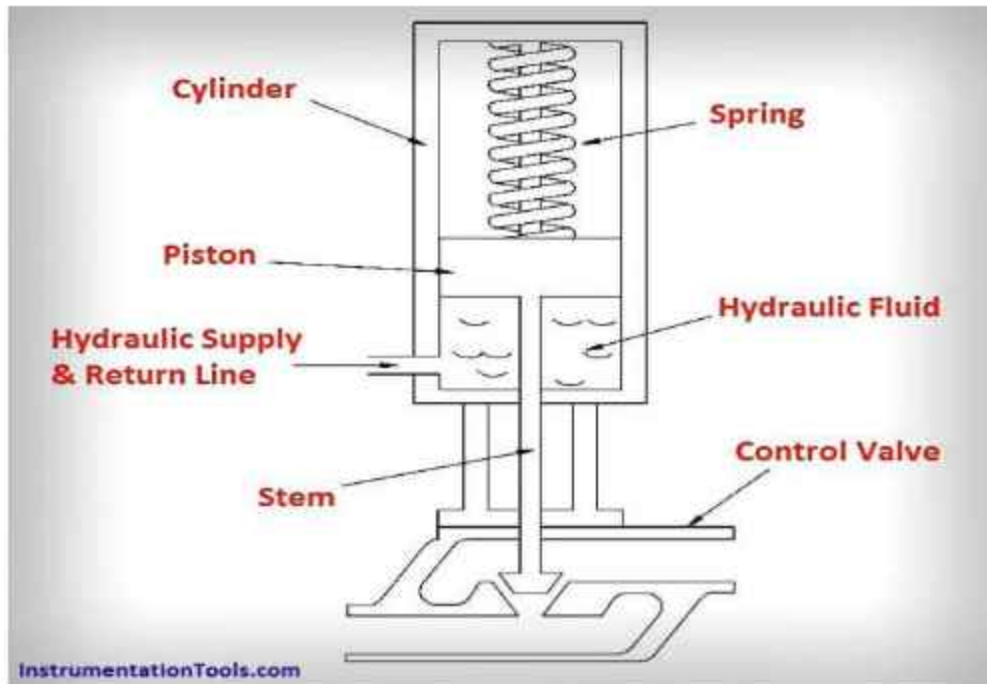

Advantages of Hydraulic Actuators

- Hydraulic actuators are suited for high force applications. They can produce forces 25 times greater than pneumatic cylinders of equal size. They also operate in pressures of up to 4,000 psi.
- A hydraulic actuator can hold force and torque constant without the pump supplying more fluid or pressure due to the incompressibility of fluids.

- Hydraulic actuators can have their pumps and motors located a considerable distance away with minimal loss of power.

DISADVANTAGES OF HYDRAULIC ACTUATORS

- Leakage of hydraulic fluid is a great problem. Leakage of hydraulic fluid leads to loss of efficiency.

Expenditure due to maintenance is high.

Cleanliness of machine and surrounding is a problem which creates damage to surrounding components and areas.

- Hydraulic actuators require many complementary parts, including a fluid reservoir, motor, pump, release valves, and heat exchangers, along with noise reduction equipment.

Hydraulic pump

- A hydraulic pump is a mechanical source of power that converts mechanical power into hydraulic energy . It generates flow with enough power to overcome pressure induced by the load at the pump outlet. When a hydraulic pump operates, it creates a vacuum at the pump inlet, which forces liquid from the reservoir into the inlet line to the pump and by mechanical action

delivers this liquid to the pump outlet and forces it into the hydraulic system.

- Types of pump
- Gear pump
- Vane pump
- piston pump

Gear pump

Types

1. External gear pump.
2. Internal gear pump.

External gear pump

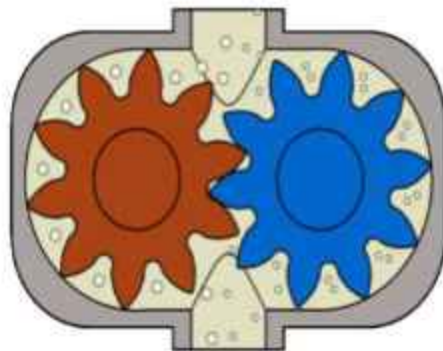

Internal gear pump



THEORY OF OPERATION

- As the gears rotate they separate on the intake side of the pump, creating a void and suction which is filled by fluid. The fluid is carried by the gears to the discharge side of the pump, where the meshing of the gears displaces the fluid. The mechanical clearances are small in the order of $10\ \mu\text{m}$. The tight clearances, along with the speed of rotation, effectively prevent the fluid from leaking backwards.

- The rigid design of the gears and houses allow for very high pressures and the ability to pump highly viscous fluids.

An external precision gear pump is usually limited to a maximum working pressure of 210 bars (21,000 kPa) and a maximum speed of 3,000 rpm.

VANE PUMP

- A Vane Pump is a type of positive displacement pump. It uses the back and forth motion of the rectangular shaped vanes inside slots to move fluids. They are sometimes also referred to as sliding vane pumps.
- A slotted rotor is eccentrically supported inside a cycloidal cam. The rotor is located close to the wall of the cam such that a crescent-shaped cavity is formed. The rotor is sealed into the cam by two side plates. Vanes or blades fit within the slots of the impeller.
- As the rotor rotates and fluid enters the pump, centrifugal force, hydraulic pressure, and/or pushrods pushes the vanes to the walls of the housing. A tight seal in the vanes, rotor, cam, and side plate is important

for good suction characteristics described in the vane pumping principles.

Vane pump



- The housing and cam forces the fluid into the pumping chamber through the holes located in the cam. Fluid enters the pockets created by the vanes, rotor, cam, and side plate.
- As the rotor rotates, the vanes sweep the fluid to the opposite side of the crescent. This fluid is then squeezed through discharge holes of the cam as the vane approaches the point of the crescent. This is

followed by the exiting of the fluid from the discharge port i.e. the outlet.

RADIAL PISTON PUMP

- **The general mode of operation will be explained at the movement pumping piston.**
The outer ring for bracing of the pumping pistons is in eccentric position to the hollow shaft in the centre. This eccentricity determines the stroke of the pumping piston.
- **The piston starts in the inner dead centre (IDC) with suction process. After a rotation angle of 180° it is finished and the workspace of the piston is filled with the moved medium. The piston is now in the outer dead centre (ODC). From this point on the piston displaces the previously sucked medium in the pressure channel of the pump.**
- **These kinds of piston pumps are characterized by the following advantages:**
 - **high efficiency**
 - **high pressure (up to 1,000 bar or 14000psi)**

- low flow and pressure ripple (due to the small dead volume in the workspace of the pumping piston)
- low noise level
- very high load at lowest speed due to the hydrostatically balanced parts possible
- no axial internal forces at the drive shaft bearing
- high reliability
- A disadvantage is the bigger radial dimensions in comparison to the axial piston pump, but it could be compensated with the shorter construction in axial direction.

Radial piston pump

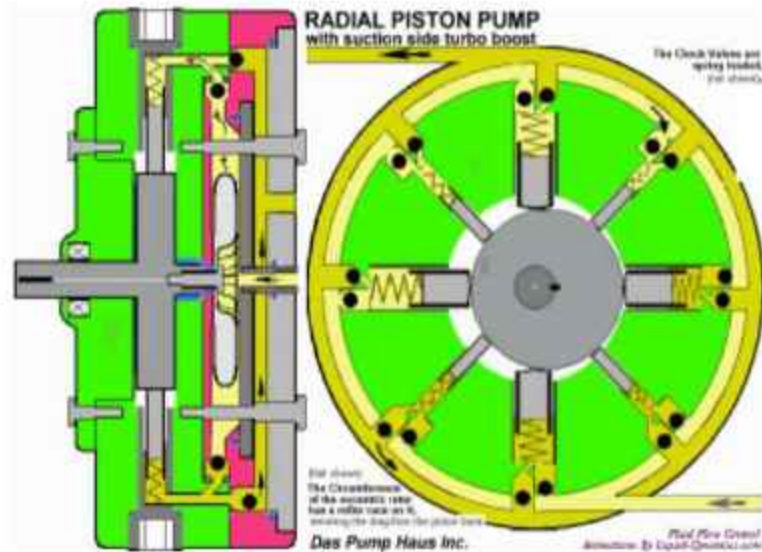

DIRECTIONAL CONTROL VALVES

- Directional control valves perform the following three functions:
- stop fluid flow
- allow fluid flow, and
- change direction of fluid flow.

These three functions usually operate in combination.

What is a directional control valve

The directional control valves can be used to start, stop, and to change the fluid flow in a hydraulic system. The major function of a directional control valve is to control the direction of flow in hydraulic systems. They are capable to determine the path through which the fluid should flow in a circuit. We can use the directional control valve to direct the inlet flow to a specific outlet port. Directional control valves are classified according to certain factors like inlet control element structure, number of ports or ways, number of position, method of actuation, and centre position flow pattern. In a directional control valve, the internal control element would be a sliding spool, rotary spool or ball. The construction and design of the directional control valves make it suitable for different applications.

SCHEMATIC DIAGRAM OF HYDRAULIC SYSTEM

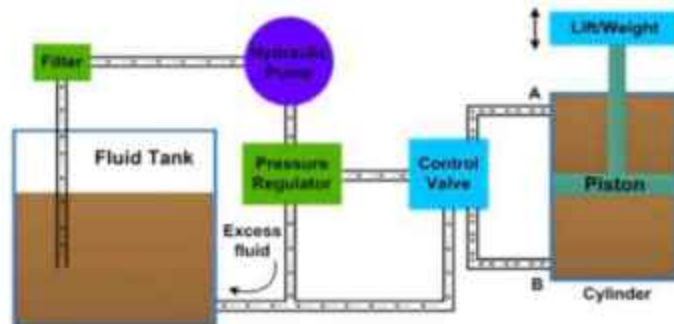

WHY DO WE NEED DIRECTIONAL CONTROL VALVES AND FOR WHAT PURPOSE DO WE USE A DCV

- It can be used to isolate a certain branch of the circuit
- It can vent the relief valve by either mechanical or electrical control
- It can allow free flow from the pump to the reservoir at low pressure during the time in which the delivery of the pump is not needed in the system

- It can also start, stop, accelerate, decelerate, and change the direction of motion of a hydraulic actuator.

WHAT IS THE FUNCTION OF A DIRECTIONAL CONTROL VALVE.

- The major function of a DCV is to control the flow or direction of the fluid in any hydraulic system. It can also choose the fluid flow path in a circuit.
- How to actuate the directional control valves
- Directional control valves can be actuated in many ways. Actuation is the process of moving the valve element from one position to another. So in a directional control valve, there are four methods of actuation they are manual, mechanical, solenoid-operated, and pilot-operated.

HOW DOES A DIRECTIONAL CONTROL VALVE (DCV) WORK

A 3-way valve has three working ports. These ports are: *inlet*, *outlet*, and *exhaust* (or *tank*). A 3-way valve not only supplies fluid to an actuator, but allows fluid to return from it as well .

3/2 DCV

The two states of the valve are open and closed. When the valve is open, fluid flows from the inlet (P, 1) to the outlet (A, 2). When the valve is closed, fluid flows from the outlet (A, 2) to the exhaust (R, 3). A valve that is closed in non-actuated state is normally closed (N.C.), the opposite is called normally open (N.O.). Most valves are mono-stable and return to their default position when they are not actuated.

3 - Way, 2 Position Valve

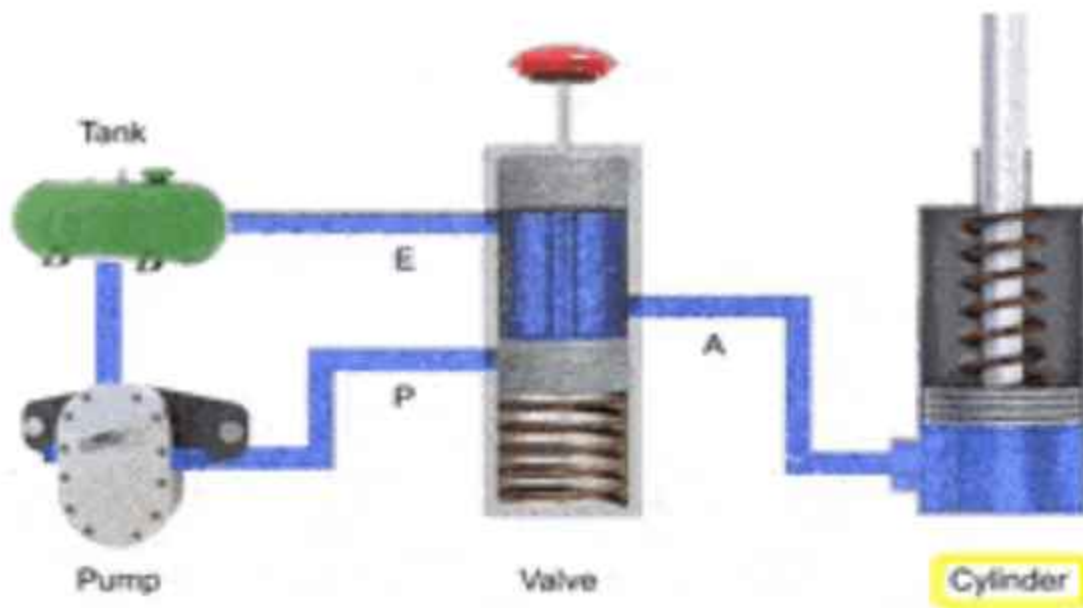

DOUBLE ACTING CYLINDER

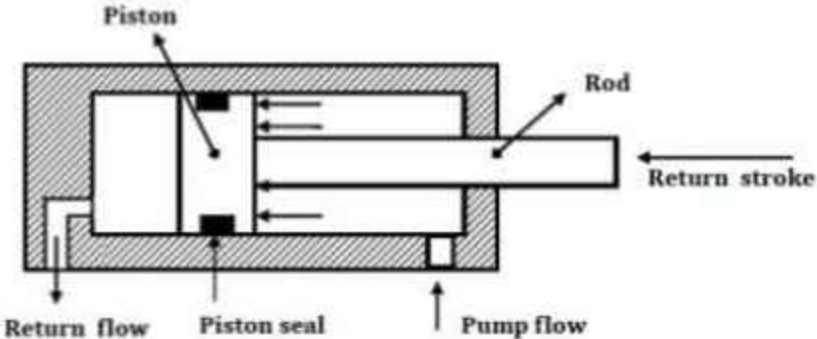
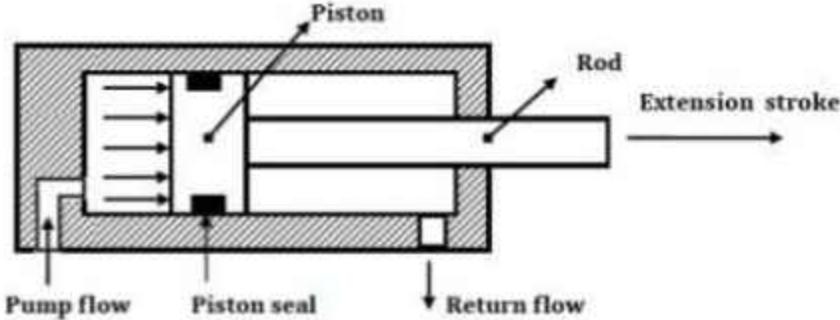

SINGLE ACTING CYLINDER

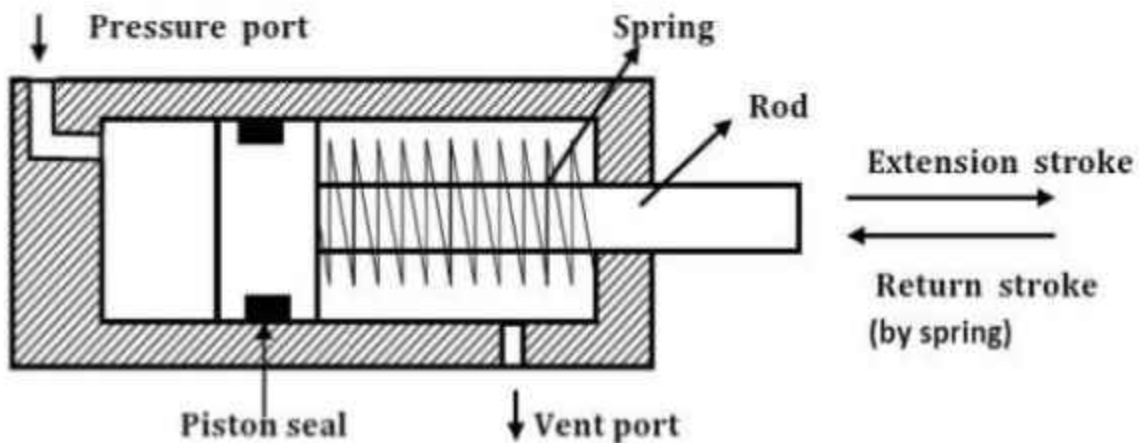

5/2 WAY DIRECTIONAL VALVE

- A 5/2 way directional valve from the name itself has 5 ports equally spaced and 2 flow positions. It can be used to isolate and simultaneously bypass a passage way for the fluid which for example should retract or extend a double acting cylinder.
- There are a variety of ways to have this valve actuated. A solenoid valve is commonly used, a lever can be manually twisted or pinched to actuate the valve, an internal

or external hydraulic or pneumatic pilot to move the shaft inside, sometimes with a spring return.

- on the other end so it will go back to its original position when pressure is gone, or a combination of any of the mention above.
- In the Illustration given, a single solenoid is used and a spring return is installed in the other end. The inlet pressure is connected to (P)1. (A)2 could possibly be connected to one end of the double acting cylinder where the piston will retract while (B)4 is connected to the other end that will make the piston extend.
- The normal position when the solenoid is de-energized is that the piston rod is blocking (B)4 and pressure coming from (P)1 passes through (A)2 that will make the cylinder normally retracted.
- When the solenoid is energized, the rod blocks (A)2 and pressure from (P)1 passes through (B)4 and will extend the cylinder and when the solenoid is de-energized, the rod bounces back to its original position because of the spring return. (E)3 and (E)5 is condemned or used as exhaust.

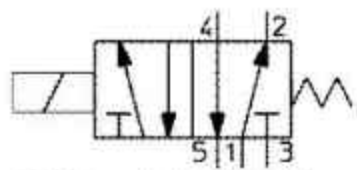

ISO port designation
(5/2-way mono-stable)

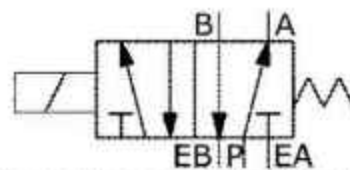

Alternative port designation
(5/2-way mono-stable)

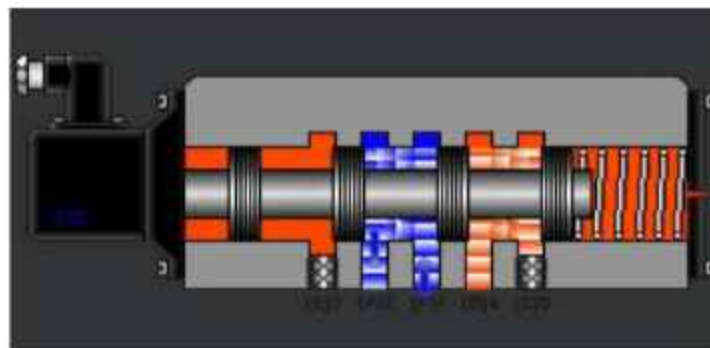

5/3 DCV

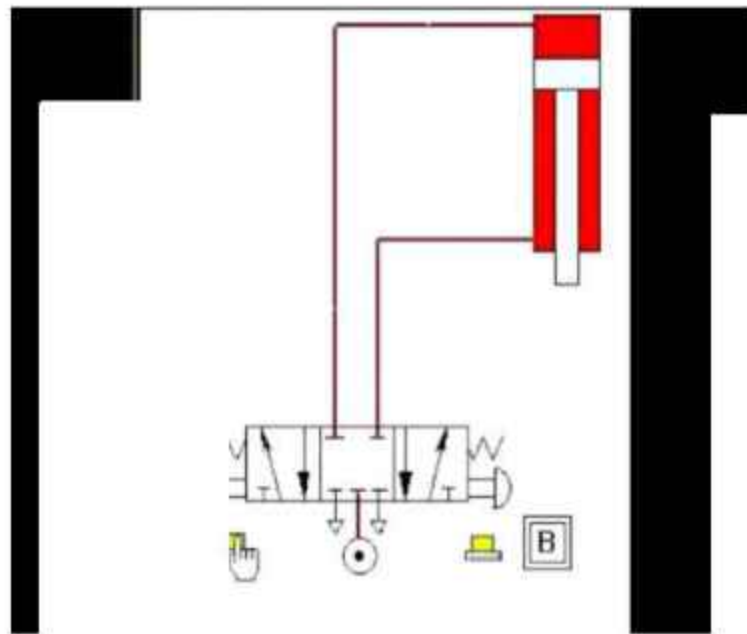

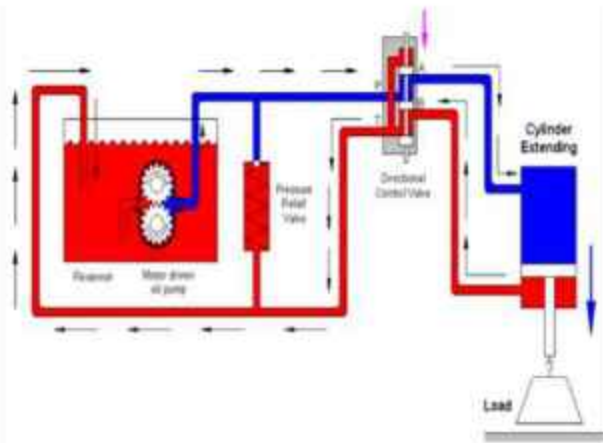

FLOW CONTROL VALVE.

The purpose of flow control in a hydraulic system is to regulate speed. All the devices discussed here control the speed of an actuator by regulating the flow rate. Flow rate also determines rate of energy transfer at any given pressure. The two are related in that the actuator force multiplied by the distance through which it moves (stroke) equals the work done on the load. The energy transferred must also equal the work done. Actuator speed determines the rate of energy transfer (power), and speed is thus a function of flow rate.

Flow control valve



HYDRAULIC THROTTLE VALVE.

A device placed in the passageway of a moving fluid in order to restrict its flow rate or to alter its pressure in the channel. Hydraulic throttles may be of the constant (non regulating) or the variable (regulating) types. Among the constant types are capillary, throttle bushing, washer, and washer-packet throttles; the variable types include those with slide-valve pairs, throttling valve nozzles, and throttling screw type nozzles.

Hydraulic throttles are used to vary the flow rate of a pressure fluid and also to regulate the speed of a machine's actuating

members. They also produce necessary pressure drops of the pressure fluid in hydraulic systems and control hydraulic actuators in hydraulic servomechanisms.

Throttling valve

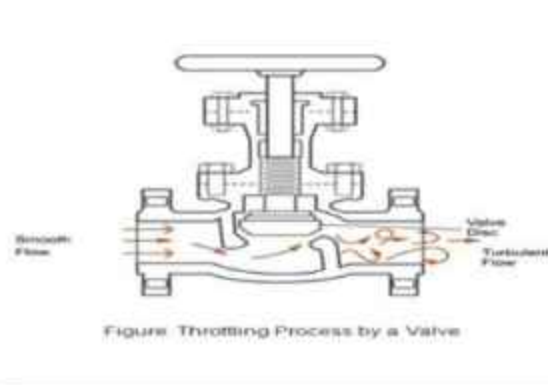

PRESSURE CONTROL VALVE

These are the units ensuring the control of pressure. A throttling orifice is present in the valve and by variation of orifice, the pressure level can be controlled or at a particular pressure, a switching action can be influenced.

Classification: Basically one differentiates between pressure regulating and pressure switching valves. Pressure regulation valves are for maintaining a constant pressure in a system. Pressure switching valves, apart from a definite control function they also

perform a switching action. Such valves not only provide a switching signal, as in the case of pressure switches, but also operate themselves as a DCV type of switching

within the hydraulic system. In the case of pressure switching valves the piston or spool of the valve remains at a definite position either open or closed depending on the control signal (Yes or No). The control signal is generally external to the valve. In the case of pressure regulating valves the piston or spool takes up in between position depending on the variable pressure and flow characteristics.

Opening and closing pressure difference.

The minimum pressure at which the valve action starts is called as the opening or cracking pressure. The difference between the cracking pressure (commencement of flow) and the pressure obtained at maximum flow (normal flow without change of spring force) is referred as the “opening pressure difference”.

Similarly the difference between the pressure corresponding to nominal flow and no flow during closing of the valve is referred as “closing pressure difference”. This is larger than the opening due to the flow forces acting in the opening direction as also the hysteresis in the spring.

Different types of pressure control valves:

Pressure control valves are usually named for their primary function such as relief valve, regulation valve,..etc.

1. Pressure Relief valve:

One of the most important pressure control is the relief valve. Its primary function is to limit the system pressure. Relief valve is found in practically all the Hydraulic

system. It is normally a closed valve whose function is to limit the pressure to a specified maximum value by diverting pump flow back to the tank. There are two basic design, a) direct operated or inertia type, b) the pilot operated design (compound relief valve).

Direct type of relief valve: The direct type of relief valve has two basic working port connection. One port is connected to pump and the other to the tank. The valve consists of a spring chamber (control chamber) with an adjustable bias spring which pushes the poppet to its seat, closing the valve. A small opening connecting the tank is provided in the control chamber to drain the oil that may collected due to leakage, thereby preventing the failure of valve. System pressure opposes the poppet, which is held on its seat by an adjustable spring. The adjustable spring is set to limit the maximum pressure that can be attained within the system. The poppet is held in position by spring force plus the dead weight of spool. When pressure exceeds this force, the poppet is forced off its seat and excess fluid in the system is bypassed back to the reservoir. When system pressure drops to or below established set value, the valve automatically reseats. Fig. below shows a direct pressure relief valve and its the symbol

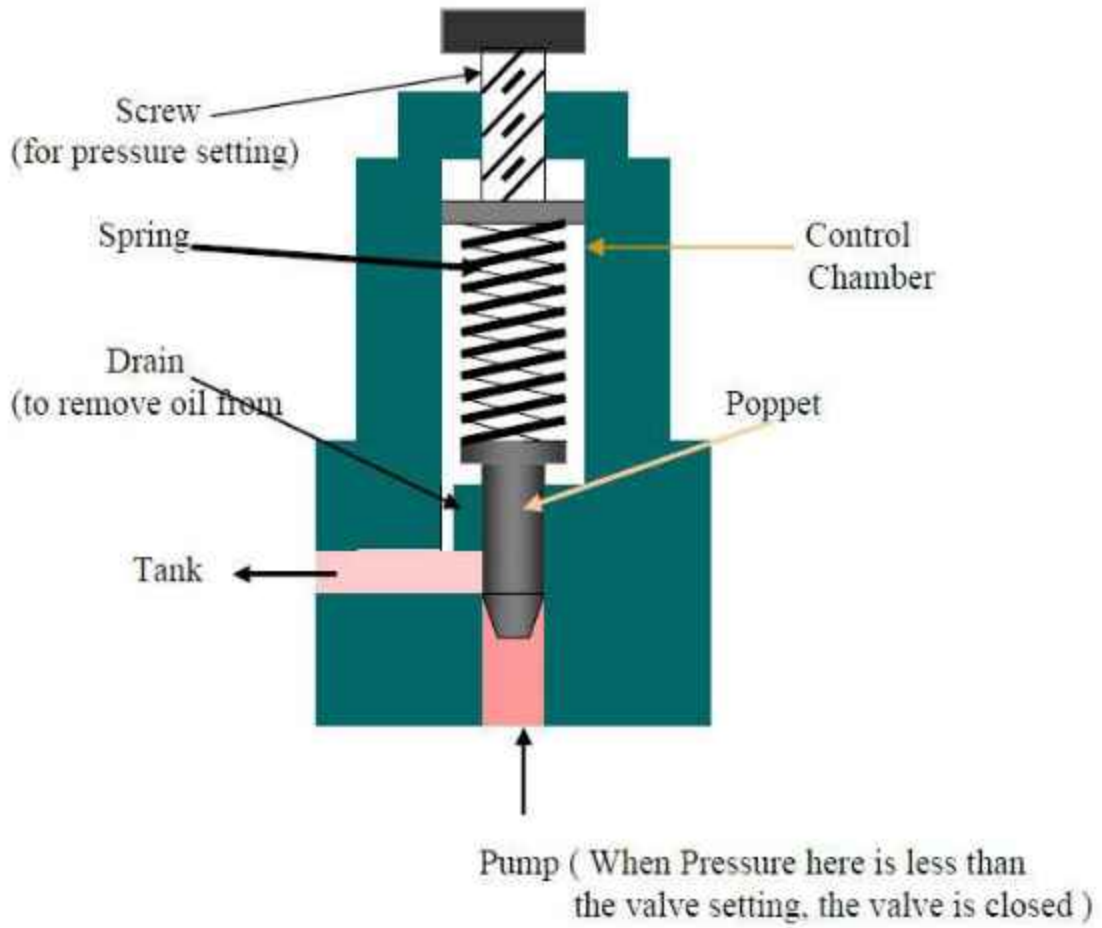

Pressure relief Valve symbol.

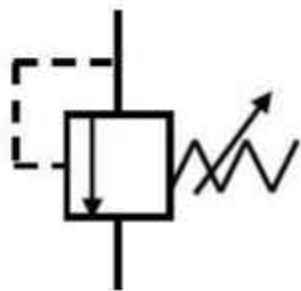

Hydraulic symbols



Square



- one square - pressure control function
- two or three adjacent squares - directional control

Diamond



- diamond - Fluid conditioner (filter, separator, lubricator, heat exchanger)

Miscellaneous Symbols

 -Spring
 -Flow Restriction

 -solid - Direction of Hydraulic Fluid Flow
 -open - Direction of Pneumatic Flow

Pumps and Compressors

Fixed Displacement hydraulic pump

 - unidirectional
 - bidirectional

Variable displacement hydraulic

Variable displacement hydraulic pump

 - unidirectional

 - bidirectional

Compressor

Motors

Fixed displacement hydraulic motor

 - unidirectional

 - bidirectional

Variable displacement hydraulic motor



- unidirectional



-bidirectional

Pneumatic motor



- unidirectional



-bidirectional

Rotary Actuator



- hydraulic



- pneumatic

Cylinders

Single acting cylinder



-returned by external force



-returned by spring or extended by spring force

Double acting cylinders



-single piston rod (fluid required to extend and retract)

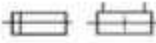

-double ended piston rod

Cylinders with cushions



- single fixed cushion

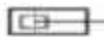

- double fixed cushion



- single adjustable cushion

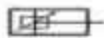

- double adjustable cushion

Directional control valve (5 ports / 2 positions) Normally a pneumatic valve



-directional control valve with 5 ports and 2 finite positions

Directional control valve (5 ports / 3 positions) Normally a pneumatic valve



-directional control valve with 5 ports and 3 finite positions

Pressure Control Valves

Pressure Relief Valve(safety valve) normally closed



- line pressure is limited to the setting of the valve, secondary part is directed to tank.

Flow Control Valves

Throttle valve



-adjustable output flow



-with fixed output (variations in inlet pressure do not affect rate of flow)
 -with fixed output and relief port to reservoir with relief for excess flow (variations in inlet pressure do not affect rate of flow)
 -with variable output
 -fixed orifice
 -metered flow toward right free flow to left
 -pressure compensated

Direct control Single-Acting Cylinder

A single-acting cylinder can exert a force in only the extending direction as fluid from the pump enters the blank end of the cylinder (usually left side of the piston). Single-acting cylinder do not retract hydraulically. Retraction is accomplished by using gravity or by the inclusion of a compression spring in the rod end. Figure below shows a two-position, three way, manually operated, spring offset directional control valve DCV used to control the operation of a single – acting cylinder. In the spring offset mode, full pump flow goes the tank via the pressure relief valve. The spring in the rod end of the cylinder retracts the piston as oil from the blank end 'A' drains back to the rank. When the valve is manually actuated the pump flow goes to the cylinder blank end 'A' via DCV 1 position. This extends the cylinder. At full extension, pump flow goes through the relief valve. Deactivation of the DCV allows the cylinder to retract as the DCV shift into its spring – offset mode

Hydraulic circuit of Direct control Single-Acting Cylinder

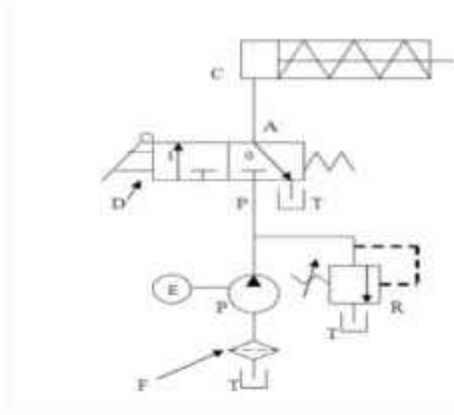

Single-Acting Cylinder

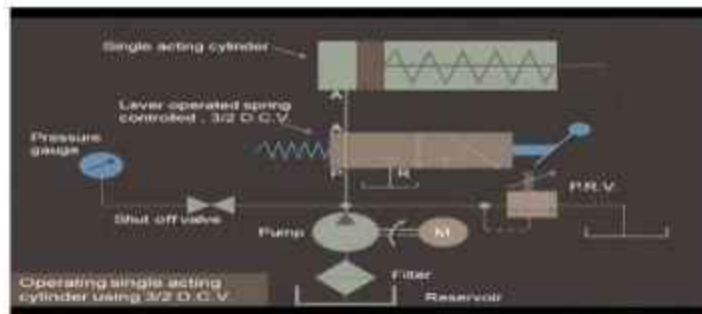

Double acting cylinder

Double –Acting cylinders can be extended and retracted hydraulically. Thus, an output force can be applied in two direction Figure below shows a circuit used to control a double – acting hydraulic cylinder. When the four way valve is in

centred configuration , the cylinder is hydraulically locked as the ports A and B is blocked. The pump flow is unloaded back to the tank at essentially atmospheric pressures.

Figure below shows a circuit used to control a double – acting hydraulic cylinder. When the four way valve is in centred configuration , the cylinder is hydraulically locked as the ports A and B is blocked. The pump flow is unloaded back to the tank at essentially atmospheric pressure.

Hydraulic circuit of operation of double acting cylinder

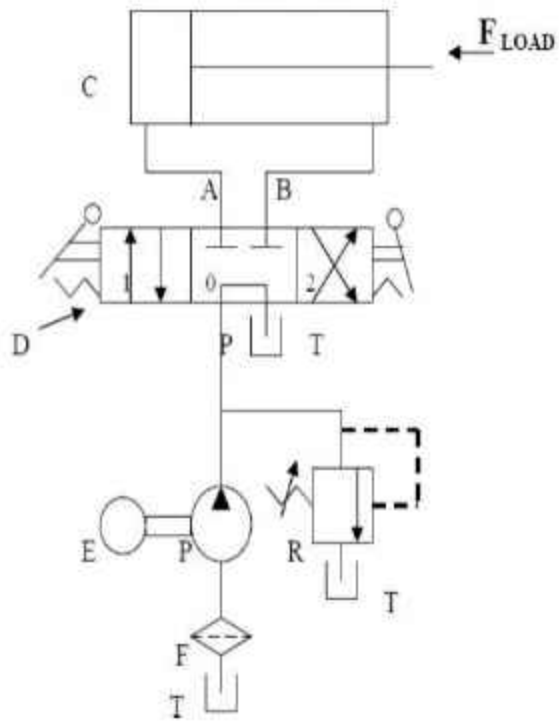

Hydraulic circuit of operation of double acting cylinder

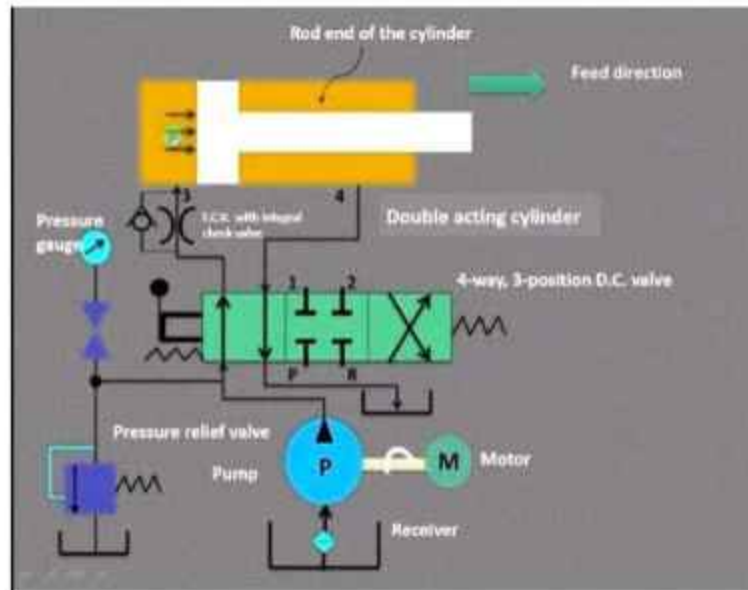

1. Hydraulic circuit of operation of double acting cylinder with metering in control.

In this type of speed control, the flow control valve is placed between the pump and the actuator. Thereby, it controls the amount of fluid going into the actuator. Fig below shows meter-in circuit. When the directional control valve is actuated to the 1st position, oil flows through

the flow control valve to extend the cylinder. The extending speed of the cylinder depends on the setting (percent of full opening position) of the flow control valve.

When the directional control valve is actuated to the 2nd position, the cylinder retracts as oil flows from the cylinder to the oil tank through the check valve as well as the flow control valve.

~~Hydraulic circuit diagram~~ **Water – in circuit diagram**

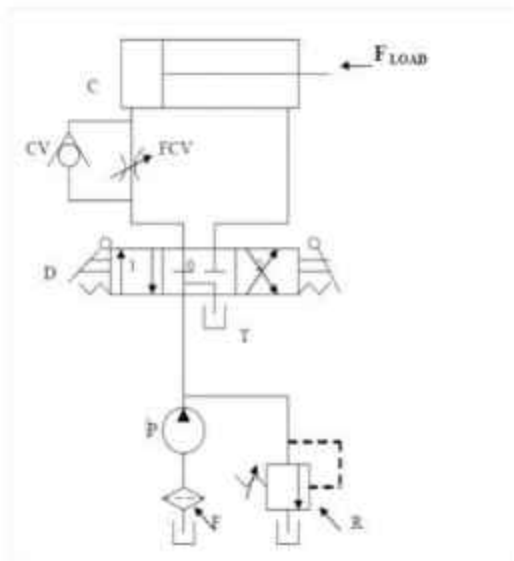

2.

Hydraulic circuit of operation of double acting cylinder with metering out control.

In this type of speed control, the flow control valve is placed between the actuator and the tank. Thereby, it controls the amount of fluid going out of the actuator. Fig below shows a meter-out circuit. One drawback of a meter-out system is the possibility of excessive pressure build up in the rod end of the cylinder while it is extending. This is due to the magnitude of back pressure that the flow control valve can create depending on its nearness to being fully closed as well as the size of the external load and the piston-to-rod area ratio of the cylinder.

~~Figure 10.14~~ Meter – out Circuit

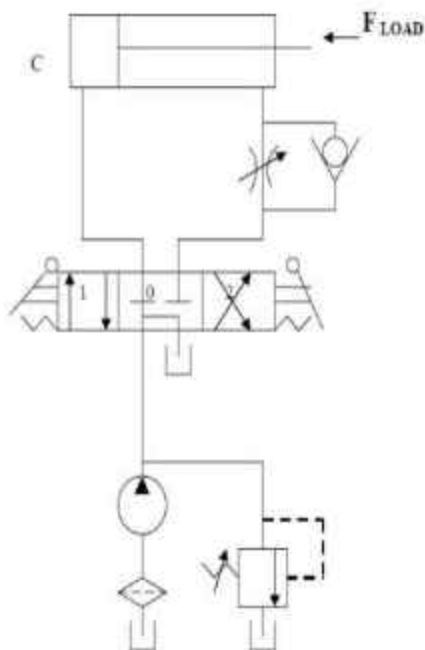

Comparison of Hydraulic & Pneumatic system