



DEPARTMENT OF PHYSICS
C.V RAMAN POLYTECHNIC
BHUBANESWAR

Name of the Lab: Applied Physics Lab
Practical: Applied Physics Lab

Contents

SL. NO	NAME OF THE EXPERIMENTS	Page No.
1	To find the cross sectional area of a wire using a screw gauge.	1
2	To find the thickness and volume of a glass piece using a screw gauge.	6
3	To find volume of a solid cylinder using a Vernier Calipers.	10
4	To find volume of a hollow cylinder using a Vernier Calipers	18
5	To determine the radius of curvature of convex surface using a Spherometer.	23
6	To determine the radius of curvature of concave surface using a Spherometer.	29
7	To find the time period of a simple pendulum and determine acceleration due to gravity	32
8	To determine the angle of Prism.	37
9	To determine the angle of Minimum Deviation by I ~ D curve method.	41
10	To trace lines of force due to a bar magnet with North pole pointing North and locate the neutral points.	46
11	To trace lines of force due to a bar magnet with North pole pointing South and locate the neutral points.	50
12	To verify Ohm's Law by Ammeter – Voltmeter method.	53
13	Reference Books	57

Introduction for the students

Just in the previous page(in the contents page), you saw the list of experiments you have to perform in the Engineering Physics Lab course. Probably, you are not convinced why you should perform these experiments. This is because these do not seem important to many of you. But aren't these important? Let us see!

It can be noticed that the first six experiments involve measurements of different physical quantities using the instruments like 1. Slide calliper, 2. Screw Gauge, and 3. Spherometer. First of all, one must understand the importance of accurate measurements in the life of an engineer and you all have just started the journey of engineering. So, let us begin with that.

In your school days, you have used scale to measure length, used meter tape to measure height or to get your dress designed. However, in the stitching of your cloth if the measurement is wrong by 0.5 cm, you won't notice any difference. But, if there is a mismatch of 1 inch (tight or loose by 1 inch), you will definitely get irritated. However, suppose you are trying to plug in your charger pin to your mobile and in that, there is a mismatch of 1 mm, you will feel like breaking the phone or the head of the manufacturer. Isn't it? Hence, it is very important to measure correctly and the scope for error (tolerance) varies from nanometre to inch depending on the need. So let us start with our first experiment i.e measurement using screw gauge/micrometer. The importance of the other experiments will be discussed eventually.

If one asks about how small we can measure using an ordinary scale present in our instrument box/geometry box, we can easily say it is one millimetre i.e $1/10^{\text{th}}$ of one 1 cm. So, the 'least count' of an ordinary scale is 1 mm. What if something is smaller than the 1mm? You can see it, but you cannot measure it using the scale you have. So, let us learn how to measure something smaller now. You will be given a thin wire. How thin? - that you will answer after performing the experiment.

Instruction to students while making lab report

1. Put page number, date and experiment number.
2. Write with the headings.
 - a. Aim of the experiment
 - b. Apparatus required
 - c. Theory (describe the instrument and theory related to the objective of experiment)
 - d. Procedure
 - e. Observation and Tabulation (the table should be numbered)
 - f. Calculation
 - g. Conclusion
 - h. Precautions
3. Draw neat labelled diagram of the instrument as well as the required diagrams described in the theory on the blank page of the lab notebook.
4. Tabulation should be done on the rolling side of the lab notebook.
5. At the end of each experiment, mention
 - a. Name
 - b. Registration No.
 - c. Semester
 - d. Branch
 - e. Section
6. Index of the lab notebook must be maintained with proper date.
7. Use pencil for drawing figures and making tables. Use pen for writing (preferably two colours; do not use red pen)

LEARNING OUTCOMES OF EXPERIMENT 1 AND 2

The students can learn

- **Different parts of the screw gauge.**
- **How to find out the distance between consecutive threads of a screw gauge**
- **How to calculate the least count of a screw gauge.**
- **How to measure length using a screw gauge**
- **How to calculate area and volume of a given specimen.**

Date:

EXPERIMENT NO. 1

To find the cross sectional area of a wire using a screw gauge.

Aim of the Experiment:

To measure the cross-sectional area of a given wire using screw gauge.

Apparatus Required:

1. Given wire
2. Screw gauge
3. Geometry box

Description of Screw Gauge:

➤ **Why the name**

Screw gauge is a measuring instrument most commonly known as the micrometer screw, used widely for precise measurement of small objects such as wire. The word screw gauge is used because the operation of this device is based upon the principle of a screw and it is used to measure the diameter of a wire .

Principle of screw gauge

- A screw gauge works on the principle of screw. This screw principle helps to convert smaller distances into larger ones by measuring the rotation of the screw. It amplifies the smaller dimensions and this converts into larger ones. When we rotate the screw, there's a linear movement on the main scale.
- **Screw gauge is also called a micrometre because it can measure very small lengths of the order of 1 micro meter.**
- When an accurately cut single threaded screw is placed inside a closely fitted nut and rotated, in addition to the circular motion there is also a linear motion of the screw along its axis. This distance moved by the screw in one complete rotation of the screw is equal to the distance between its two consecutive threads. This distance is called the pitch and it's always constant.

Theory:

- In **figure 1**, an image of a typical screw gauge is presented. With the ratchet, the circular scale can be moved over the linear scale. **The distance covered on the linear scale with one complete rotation is called Pitch of screw gauge.**
- In a micrometer screw, the pitch is usually 1 mm or 0.5 mm. It can be seen that the circular scale also has divisions on it. In general, the number is either 50, 100 or 200.
- So, while rotating, one can estimate the distance travelled on the linear scale by noticing the no. of divisions on the circular scale.
- The smallest distance we can measure by the screw gauge is called the **least count** of the screw gauge which is given by

$$\text{Least count} = \frac{\text{Pitch}}{\text{Total no. of divisions on the circular scale}} = \text{-----cm (equation-1)}$$

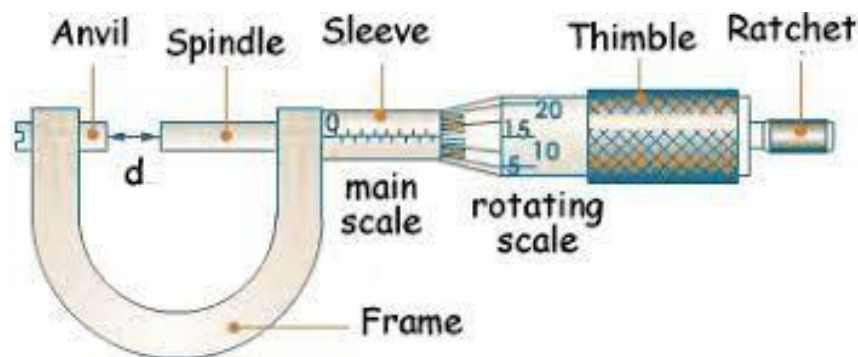

Figure 1.1: Schematic of a typical screw gauge

In general, the screw gauge has a least count of 0.001 cm.

Procedure:

- Standardize the linear scale. This means, measure the length of one division of the linear scale using the scale in your geometry box/instrument box. Usually, 10 divisions is equal to 1 cm or 0.5 cm. Accordingly, one division is 1 mm or 0.5 mm.
- Rotate the screw through, say, ten complete rotations and observe the distance through which it has receded.
- Then, find the pitch of the screw, i.e., the distance moved by the screw in one complete rotation.
- If there are n divisions on the circular scale, then distance moved by the screw when it is rotated through one division on the circular scale is called the least count of the screw gauge. It is given by equation 1.
- Determine the least count.
- Put the wire in between the anvil/ stud and the spindle. Move the screw forward by rotating the ratchet till the wire is gently gripped between the spindle and the anvil (as shown in figure 1.2 and 1.3)

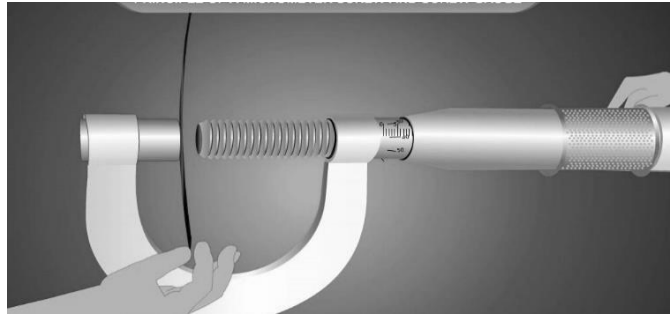

Figure 1.2: Placing the wire for measurement

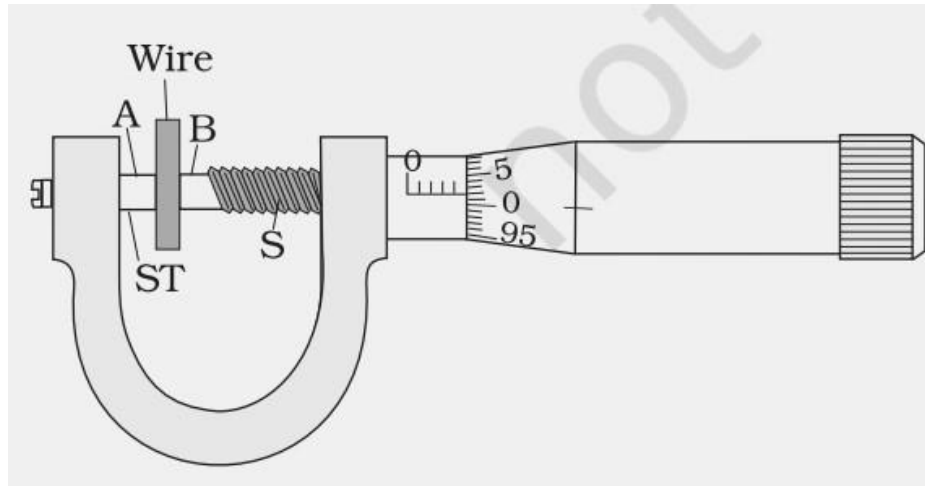

Figure 1.3: Observation of circular scale reading

- Note the division on the linear scale. Tabulate it as the **initial circular scale reading (ICSR)**.
- Now slightly loosen the screw. Remove the wire. Rotate the screw using the ratchet. Keep track of the no. of complete rotation till the screw/spindle touches the anvil (a sound can be heard).
- Note the no. of complete rotation (N) and the **final circular scale reading (FCSR)**.
- Find the difference $D = (ICSR - FCSR)$

$$D = ICSR - FCSR \text{ (if } ICSR > FCSR \text{)}$$

$$D = (ICSR + \text{No. of total divisions on the circular scale}) - FCSR; \\ \text{(if } ICSR < FCSR \text{)}$$

- Calculate **pitch scale reading (PSR) = Pitch \times No. of complete rotation**
- Calculate **circular scale reading (CSR) = D \times least count**
- **Here the circular scale reading is calculated by the difference in initial and final reading for which zero error if any is cancelled.**
- These data will be tabulated in the below format in the next page.

WORKING FORMULA

$$A = \frac{\pi \times d^2}{4},$$

A \Rightarrow Cross Sectional Area of the given wire

d \Rightarrow Mean or Average Diameter of given wire

TABULATION FOR MEAN DIAMETER (d) OF THE WIRE :

Sl. No.	PITCH	LC	ICSR	N	FCSR	Difference D = I ~ F	PSR = Pitch × N in cm	CSR = D × LC in cm	d = PSR + CSR in cm	Mean d in cm
1.										
2.										
3.										
4.										
5.										
6.										
7.										
8.										
9.										
10.										

Observation and Calculation:

The length of the smallest division on the linear scale = _____ cm

Distance moved by the screw when it is rotated through 10 complete rotations

$$= x = \text{_____ cm}$$

Pitch of the screw = $x / 10 = \text{_____ cm}$

Number of divisions on the circular scale = $n = \text{_____}$

Least Count (L.C.) of screw gauge = $x / (10 \times n) = \text{_____ cm}$

The diameter (d) of the wire was found out to be _____ cm

The cross-sectional area of the wire = $\frac{\pi \times d^2}{4} = \text{_____ cm}^2$

Conclusion:

The cross-sectional area of the given wire was found out to be _____ cm².

Precautions:

1. The screw should always be rotated by ratchet to avoid undue pressure.
2. To avoid back-lash error in the screw, the screw should be moved in the same direction.
3. The reading should be taken repeatedly at different places/orientation of the supplied specimen.
4. View all the reading keeping the eye perpendicular to the scale to avoid error due to parallax
5. While measuring, care should be taken such that no portion of the object under measurement touches the U-shaped frame of the instrument.
6. The given body should be kept lightly between the gaps so that it can be removed conveniently without disturbing the gap.

REVIEW QUESTIONS ON EXPERIMENT NO - 1

Q1. Why is the instrument named screw gauge?

Ans: The instrument is called a screw gauge, because it uses a screw to amplify a very small movement so that it can easily be read.

Q2. Define pitch of the screw.

Ans: The distance covered on the linear scale with one complete rotation is called **Pitch** of screw gauge

Q3. Define Least Count of the screw gauge.

Ans: The smallest distance we can measure by the screw gauge is called the least count of the screw gauge.

Q4. How can you determine the number of complete rotation?

Ans: 360 degree rotation starting from the initial reading coming back to the same reading.

Q5. Can you measure the radius of a hair by screw gauge? If not why?

Ans: Because it is very less than the least count of the screw gauge.

Q6. Between Slide callipers and screw gauge, which instrument will give more accurate measurement and why?

Ans: Screw gauge is more accurate as it gives the reading upto three or four decimal places as compared to slide calliper.

Q7. Can you measure the thickness of a plane paper using screw gauge? If yes how? If not why?

Ans: Yes, by folding the paper to several times and after taking the reading dividing it with the number of folds, will give the actual thickness of the paper.

Date:

EXPERIMENT NO. 2

To find out the thickness and volume of a glass piece using Screw Gauge

Aim of the Experiment:

To measure the thickness and volume of the given glass piece using screw gauge.

Apparatus Required:

1. Supplied glass piece
2. Screw gauge/micrometer Screw
3. Instrument box
4. Graph paper

Theory:

In the case of regular shaped glass piece (for example circle, rectangle and triangle), the area can be estimated using the measured parameters (e.g. length, breadth, radius or height). However, in the case of irregular lamina, graph paper must be used for the determination of area. Thickness is measured using the screw gauge. To find the thickness of the glass plate, it is gripped between the tip of the screw and the anvil. The PSR and CSR are noted as before.

The thickness of the glass plate is;

$$\text{Thickness}(t) = \text{PSR} + \text{CSR}$$

PSR= Pitch x N (no. of complete rotation)

CSR= Difference x Least count (L.C)

To find the Volume of glass plate (irregular lamina), find the thickness, t of irregular lamina as before. Then place the lamina over a graph paper and trace its outline on the graph paper. The area A of the lamina is taken from the graph paper.

The volume of the glass plate is calculated from the equation;

$$\text{The volume of the glass piece} = \text{area} \times \text{thickness}$$

Procedure:

- Measure the thickness of the screw gauge using the method described in the experiment no.1. Only difference is instead of the wire you will be putting the glass piece. Tabulate the observations.
- For measurement of area of the glass plate, put it on a graph paper. Draw its outline on the paper using a sharp pencil. A typical picture is presented in figure 2.1.

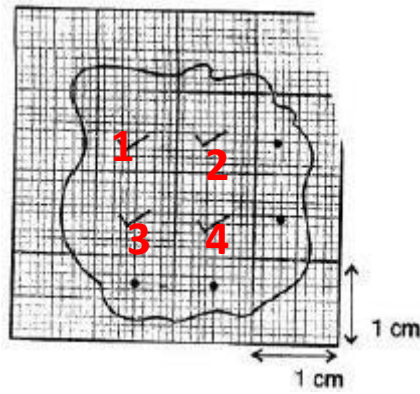

Figure 2.1: The outline of the glass piece on a graph paper.

- Now remove the piece. First count the biggest square of area (type A) $1\text{cm} \times 1\text{ cm}$. Note down its number. You can write numbers on the respective squares for a better tracking and ease of counting.
- Then, from the left over area, count the number of squares with area $0.5\text{ cm} \times 0.5\text{ cm}$ (type B).
- Then, count the smallest squares of area $0.1\text{ cm} \times 0.1\text{ cm}$ (type C).
- Now put the glass piece on another part of the graph paper and repeat the above procedure.
- Tabulate the observations.

Observation :

TABULATION -1 FOR MEAN THICKNESS (d) OF THE GLASS PIECE:

Sl. No.	PITCH	LC	ICSR	N	FCSR	Difference $D = I \sim F$	PSR= Pitch \times N in cm	CSR = $D \times LC$ in cm	d = PSR+CSR in cm	Mean d in cm
11.										
12.										
13.										
14.										
15.										
16.										
17.										
18.										
19.										
20.										

TABULATION -2 FOR THE MEAN AREA OF THE IRREGULAR LAMINA:

Sl. No	No. of squares of type A	Area comprising the squares of type A in cm^2	No. of squares of type B	Area comprising the squares of type B in cm^2	No. of squares of type C	Area comprising the squares of type C in cm^2	Area of the glass piece in cm^2	Mean area in cm^2
1								
2								
3								
4								
5								

Calculation:

From the tabulation 1 , the thickness of the glass piece = $d = \underline{\hspace{2cm}}$ cm

From the tabulation 2 , the area of the glass piece = $A = \underline{\hspace{2cm}}$ cm^2

Hence, the volume of the glass piece = $\text{area} \times \text{thickness} = A \times d = \underline{\hspace{2cm}}$ cm^3

Conclusion:

The volume of the given glass piece was found out to be $\underline{\hspace{2cm}}$ cm^3 by using a screw gauge and graph paper.

Precautions

The precautions remain same as the ones in experiment no. 1 and the outline of the piece on the graph paper must be made carefully

REVIEW QUESTIONS ON EXPERIMENT NO - 2

Q1. Explain the reason why the screw used in the screw gauge is known as a micrometre screw.

Answer: It is known as a micrometre screw because it can measure distance correctly up to a micrometre. (10^{-6}m)

Q2. What is the principle of screw gauge?

Answer: When a screw moves in a fixed nut, the translatory motion of the screw is proportional to the rotation given to the screw.

Q3. List the different types of motion possessed by a screw.

Answer: It possesses two motions, and they are:

- (i) linear motion possessed by the axis
- (ii) circular motion possessed by the surface

Q4. Define the pitch of the screw gauge.

Answer: The distance moved by the screw in one complete rotation is known as the pitch of the screw gauge.

Q5. What is the value of the least count in commonly used screw gauge?

Answer: The least count in commonly used screw gauge is 0.001 cm.

Q6. How can the backlash error be avoided?

Answer: It can be avoided by applying slight lateral pressure on the screw and by always turning in the same direction.

Q7. Which metal is used to make the screw and why?

Answer: The screw is made of gunmetal to avoid wear and tear after long use.

Q8. Define the least count of screw gauge.

Answer: The distance moved by the screw in one complete rotation is known as the least count.

Q9. What is ratchet? Explain its utility.

Answer: Ratchet is referred to as the arrangement inside the milled head at the end of the screw. It prevents the screw from undue pressure.

LEARNING OUTCOMES OF EXPERIMENT NO. 3 AND 4:

- **The student will learn about the principle of vernier.**
- **The student will learn about the operation of Slide Calliper.**
- **They will know the least count of slide calliper and will be able to measure length, diameter etc.**
- **The student will know the formula for volume and surface of solid and hollow cylinder.**
- **The student will learn about the application of Slide Calliper**

EXPERIMENT NO. 3

Date:

To find out the volume of a solid cylinder using Vernier calliper/ slide calliper

Aim of the Experiment:

To find the volume of a solid cylinder using a Vernier Calliper / Slide calliper

Apparatus required:

1. Given solid cylinder
2. Slide calliper/Vernier calliper
3. Instrument box

Theory:

Description of Vernier Calliper:

The Vernier calliper consists of two scales – main scale and Vernier scale. As the Vernier scale slides over the main scale, it is also known as slide calliper. The main scale and Vernier scale are divided into smaller divisions. The magnitude of the divisions are different from each other. In the figure-3.1 below, a labelled Vernier calliper is presented.

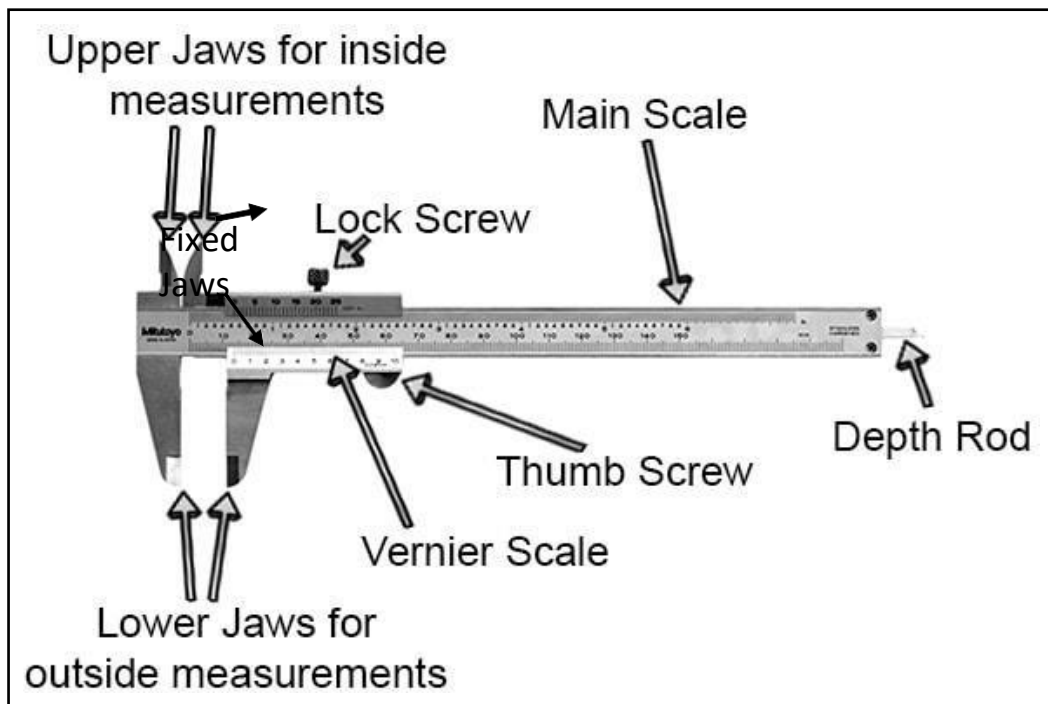

Figure 3.1: A labelled Slide calliper

The main scale is graduated in cm and mm. It has two fixed jaws attached. The Vernier scale also has movable jaws which is moved using the thumb screw.

Least Count:

The minimum measurement that can be measured using a Vernier calliper is called the least count (LC) of the Vernier calliper.

$$LC = 1 \text{ main scale division} - 1 \text{ vernier scale division} = 1MSD - 1VSD$$

Zero Error:

When the jaws are closed (touch each other), the zero of main scale (MS) should coincide with the zero of Vernier scale (VS). Then, it is said that there is no zero error.

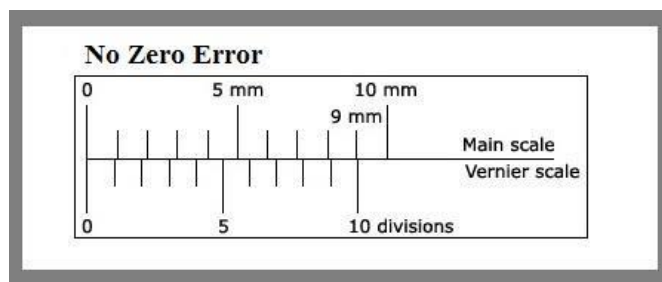

Fig. 3.2

Zero error is of two types.

Positive Zero error:

If the zero of the VS is at the right of the zero of the MS, then the vernier calliper is said to have positive zero error.

$$\text{Positive Zero error} = \text{Vernier Coincidence} \times \text{L.C}$$

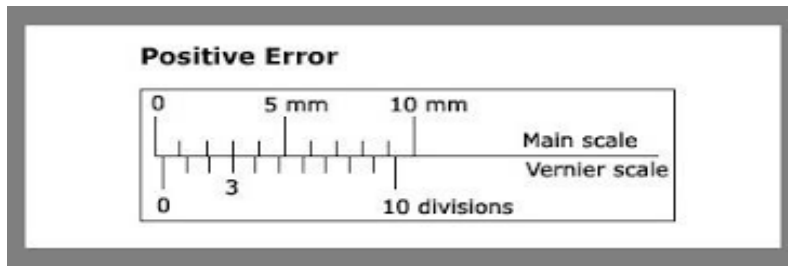

Fig. 3.3

Negative Zero error:

If the zero of the VS is at the left of the zero of the MS, then the vernier calliper is said to have negative zero error.

$$\text{Negative Zero error} = (\text{Total no. of division on the VS} - \text{VC}) \times \text{L.C.}$$

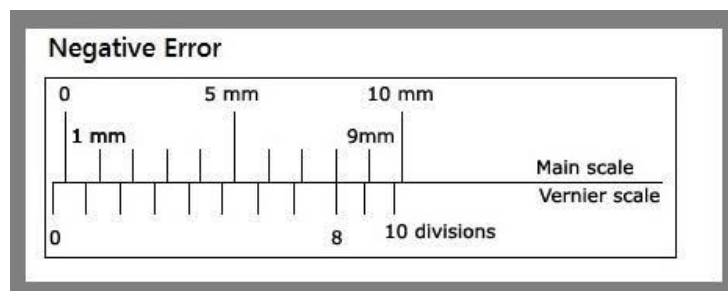

Fig. 3.4

The estimation of zero error is illustrated in the below figure.

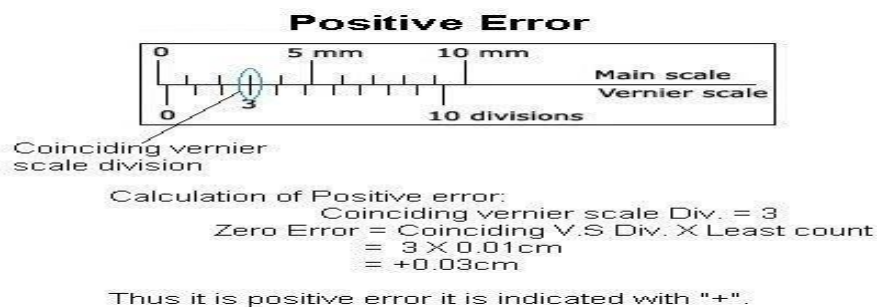
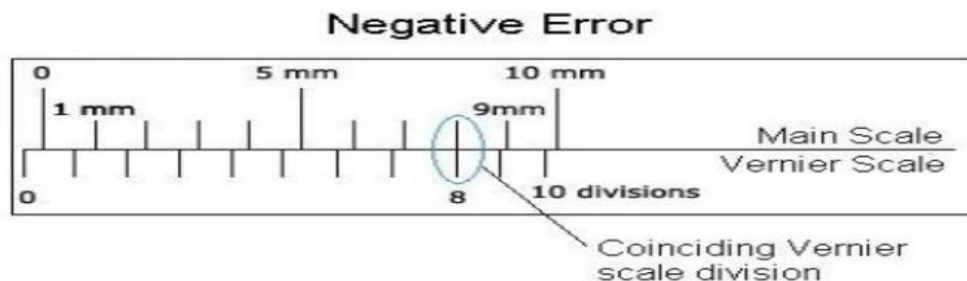

Fig. 3.5

Negative Zero Error

In **negative zero error**, we will bring the two jaws together. Here you can see zero of vernier scale is the back side of main scale zero. Or to the left of main scale zero.



Calculation of Negative error:

$$\begin{aligned} \text{Coinciding vernier scale div.} &= 8 \\ \text{Difference} &= \text{Total div.} - \text{Coinciding div.} \\ &= 10 - 8 = 2 \end{aligned}$$

$$\begin{aligned} \text{Now, Zero error} &= \text{Difference} \times \text{Least count} \\ &= 2 \times 0.01 \text{ cm} \\ &= -0.02 \text{ cm} \end{aligned}$$

The minus sign indicates the negative error in vernier caliper.

Figure 3.6:

Zero error should be subtracted/ added from the observed reading to get the correct reading.

$$\text{Actual Reading} = \text{Observed reading} - (\text{Zero error}) \text{ (for +ve zero error)}$$

$$\text{Actual Reading} = \text{Observed Reading} + (\text{Zero error}) \text{ (for -ve zero error)}$$

Procedure:

1. Standardise the main scale.
2. Keep the jaws of Vernier Callipers closed. Observe the zero mark of the main scale. It must perfectly coincide with that of the Vernier scale. If this is not so, determine the zero error.
3. Determine the least count of the instrument.

Method -

$$10 \text{ MSD} = 1 \text{ cm (say)} \Rightarrow 1 \text{ MSD} = \frac{1}{10} \text{ cm} = 0.1 \text{ cm}$$

Notice that 10 VSD = 9 MSD

$$\Rightarrow 1 \text{ VSD} = \frac{9}{10} \text{ MSD} = 0.9 \times 0.1 \text{ cm} = 0.09 \text{ cm}$$

$$\text{Least count} = 1 \text{ MSD} - 1 \text{ VSD} = (0.1 - 0.09) \text{ cm} = 0.01 \text{ cm}$$

LC of slide calliper = 0.01 cm

4. Keep the solid cylinder length wise to determine height. Keep the jaw parallel to the diameter of the cylinder. Gently tighten the screw so as to clamp the instrument in this position.
5. Notice the reading on the main scale with which the zero of the Vernier scale coincides. Note that as main scale reading (MSR). Position your eye directly over the division mark so as to avoid any parallax error
6. If the zero of vernier scale does not exactly coincide with a line on the main scale, then the reading on the **left** of the zero of vernier scale should be taken as MSR.
7. Look for exact coincidence of a vernier scale division with that of any main scale division in the vernier window from left end (zero) to the right. Note its number, carefully. Note the number as vernier coincidence (VC).
8. Calculate the vernier scale reading (VSR) = VC × LC
9. Determine the height using formula

$$\text{Height} = \text{MSR} + \text{VSR}$$
10. Use same method to determine the diameter of the cylinder.
11. Make repeated observations with different orientations/positions of the cylinder and input the observation in tabular form.
12. Calculate the mean height and mean diameter.
13. Correct it for zero error if any.

Observations:

1 MSD = _____ cm

Number of vernier scale divisions, N = _____

N vernier scale divisions = _____ main scale divisions

1 VSD = _____ cm

The least count of the given slide calliper = _____ cm

The zero error of the given slide calliper is = _____ cm

WORKING FORMULA :

$$V = \frac{\pi \times D^2 \times h}{4}$$

V = Volume of Solid Cylinder

D = Mean Diameter of Solid Cylinder

h = Mean Height or Mean length of solid cylinder

TABULATION - 1 FOR MEAN HEIGHT OR LENGTH OF THE SOLID CYLINDER:

Sl. No.	Least count (LC)	MSR in cm	Vernier coincidence (VC)	VSR= VC x LC in cm	Observed height (MSR+VSR) in cm	Zero error	Actual Height = observed height \pm zero error	Mean Height (h) in cm
1								
2								
3								
4								
5								
6								
7								
8								
9								
10								

TABULATION - 2 FOR MEAN EXTERNAL DIAMETER OF THE SOLID CYLINDER:

Sl. No.	Least count (L.C)	MSR in cm	Vernier coincidence (VC)	VSR= VC x LC in cm	Observed external diameter (MSR+VSR) in cm	Zero error	Actual external diameter =observed external diameter \pm zero error	Mean external diameter (D)in cm

Calculations:

The observed height or length of the given cylinder is = _____ cm

The true height or length of the cylinder = observed height \pm zero error = h = _____ cm

The observed diameter of the given cylinder is = _____ cm

The true diameter of the cylinder = observed height \pm zero error = D = _____ cm

Hence, the volume of the given solid cylinder = $\frac{\pi \times D^2 \times h}{4}$ = _____ cm³

Conclusion:

The volume of the given solid cylinder was found out to be _____ cm³.

Precautions:

1. If the vernier scale is not sliding smoothly over the main scale, apply machine oil/grease.
2. Screw the vernier tightly without exerting undue pressure to avoid any damage to it.
3. Keep the eye directly over the division mark to avoid any error due to parallax.
4. Note down each observation with correct significant figures and units.
4. Avoid undue pressure while keeping the object between the jaws. Also, the object should not be held loose.
5. The procedure should be represented at least 10 times in different positions of the cylinder since the cylinder may not be regular.

REVIEW QUESTIONS ON EXPERIMENT NO. 3

Q1. What is meant by least count of an instrument?

Answer: It is the smallest measurement that can be made with the given instrument

Q2. What is meant by least count of a vernier callipers?

Answer: It is the smallest length that can be measured with the instrument and it is equal to the difference between a main scale division and a vernier scale division.

Q3. The least count of a vernier is 0.01 cm. What is the order up to which it can measure length accurately?

Answer: It can measure accurately up to 10^{-2} cm.

Q4. What part of the vernier callipers is the vernier scale?

Answer: The sliding scale along the main scale is called vernier scale.

Q5. Which is the instrument you will use to measure the internal and external diameter of a tube?

Answer: Vernier calliper

EXPERIMENT NO. 4:

Date:

To find the volume of a hollow cylinder using vernier calliper/slide calliper

Aim of the experiment:

To determine the volume of a hollow cylinder using a Vernier Calliper/slide calliper.

Apparatus required

1. Given hollow cylinder
2. Slide calliper/Vernier calliper
3. Instrument box

Theory:

The theory remains same as in expt. No. 3. The theory is to be written again in the lab report of a student.

Procedure:

- Measure the height and external diameter of the hollow cylinder with the cylinder held between the lower jaws. Use the same method as described in the experiment 3.
- Measure the internal diameter of the hollow cylinder with the cylinder held with the upper jaws.
- Take 10 observations with different orientation/position of the hollow cylinder while determining height, internal diameter and external diameter. Tabulate them.
- Calculate the mean height, internal diameter and external diameter.
- Correct for the zero error if any.
- Calculate the volume of the hollow cylinder.

Observations:

1 MSD = _____ cm

10 VSD = _____ MSD

⇒ 1 VSD = _____ MSD

Least Count = 1 MSD – 1 VSD = _____ cm

Zero error of the slide calliper = _____ cm

WORKING FORMULA :

$$V = \frac{\pi \times (D^2 - d^2) \times h}{4}, \quad V = \text{Volume of Solid Cylinder}$$

D = Mean External Diameter of Hollow Cylinder

d = Mean Internal Diameter of Hollow Cylinder

h = Mean Height or Mean length of Hollow cylinder

TABULATION -1 FOR THE MEAN HEIGHT OR LENGTH OF THE HOLLOW CYLINDER

Sl. No.	Least count (LC)	MSR in cm	Vernier coincidence (VC)	VSR = VC x LC in cm	Observed height (MSR+VSR) in cm	Zero error	Actual Height = observed height ± zero error	Mean Height or length (h) in cm

Calculation:

The observed height of the hollow cylinder = _____ cm

The true height of the hollow cylinder = Observed height \pm zero error = h = _____ cm

The observed external diameter = _____ cm

The true external diameter = D = Observed external Diameter \pm zero error = _____ cm

The observed internal diameter = _____ cm

The true internal diameter = d = Observed internal Diameter \pm zero error = _____ cm

Hence, the volume of the hollow cylinder = $V = \frac{\pi \times (D^2 - d^2) \times h}{4} = \text{_____ cm}^3$

Conclusion:

The volume of the given hollow cylinder were found out to be _____ cm³.

Precautions:

The precautions are the same as the ones in experiment no. 3

REVIEW QUESTIONS ON EXPERIMENT NO- 4

Q1.What is the principle of a vernier?

Answer: The vernier scale uses the alignment of line segments displaced by a small amount to make fine measurements.

Q2.How is the least count of vernier callipers calculated?

Answer: Least count also known as the vernier constant is the difference between one main scale division (1 mm) and one vernier scale division (0.9 mm). It can also be calculated by dividing the smallest unit on the main scale by the total numbers on the vernier scale.

Q3.Define Vernier constant.

Answer: Vernier constant is the difference between the smallest division of main scale and the of Vernier scale.

Q4.What is parallax error and how can it be avoided?

Answer: Parallax is an effect where the direction and position of the object appear to differ when viewed from different lines of sight.

Q5.What are the uses of vernier callipers?

Answer: The uses of vernier callipers are as follows:

Used in science labs

Used in steel industries

Used in aerospace industries

Used in automobile industries

LEARNING OUTCOMES OF EXPERIMENT NO. 5 AND 6:

- **The student will learn about the operation of Spherometer**
- **They will know the least count of Spherometer and will be able to measure small curvature.**
- **The student will know the formula for radius** of curvature of concave/convex surfaces.

EXPERIMENT NO. 05

Date:

To determine the radius of curvature of convex surface using a Spherometer

Aim of the Experiment:

To determine the radius of curvature of convex surface using a Spherometer.

Apparatus Required:

1. Spherometer
2. The curved piece of glass
3. Base Plate
4. Instrument box

Theory:

Description of Spherometer:

The working principle of the spherometer is that of a micrometer screw. It consists of a metallic framework with three legs of equal length (tripod). The tips of the three legs form three corners of an equilateral triangle. The spherometer also has a central leg which can be raised or lowered through a threaded hole in the metal frame using the screw head. The lower tip of the central screw, when lowered touches the centre of the triangle formed by the three legs. The central screw also carries a circular scale. The circular scale is in general divided into 50 or 100 equal parts. A small vertical scale marked in millimetres or half-millimetres is fixed parallel to the central screw. This scale is called linear scale. This scale is very close to the rim of circular scale but it does not touch it. This scale reads the vertical distance which the central leg moves through the hole. This scale is also known as pitch scale.

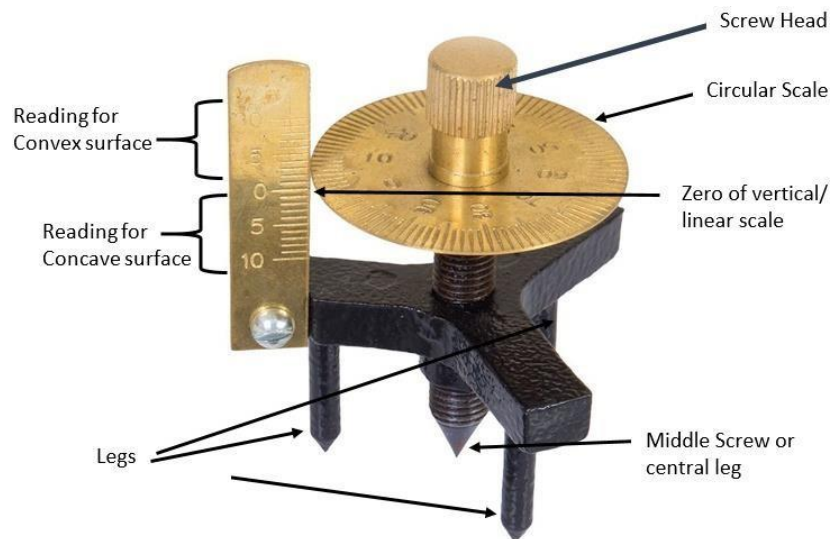

Figure 5.1 : A labelled spherometer

Pitch of the Spherometer:

The distance covered on the linear scale (vertical scale) by 1 complete rotation of the circular scale is called **PITCH** of spherometer.

Least count of the Spherometer:

Least count of the spherometer is defined the minimum measurement that can be carried out using it. In other words, it is the distance moved by the circular screw, when the circular screw is rotated by *one division* on the circular scale.

$$\text{Hence, Least Count} = \frac{\text{Pitch}}{\text{Total number of divisions on the circular scale}} = \text{----- cm}$$

Formula for radius of curvature:

$$\mathbf{R} = \frac{d^2}{6h} + \frac{h}{2}$$

R= Radius of curvature of the spherical surface

d = Mean distance between consecutive legs of the Spherometer

h = Height through which the central leg is raised = Height of the Convex Surface

The given curved surface is a part of a full sphere. The radius of the sphere is called the radius of curvature. A vertical section of the sphere is presented in the figure below.

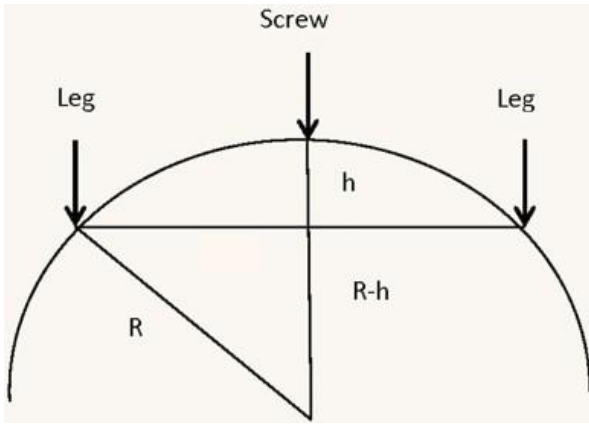

Figure 5.2 : Schematic vertical section of the spherometer legs and screw placed on a curved surface

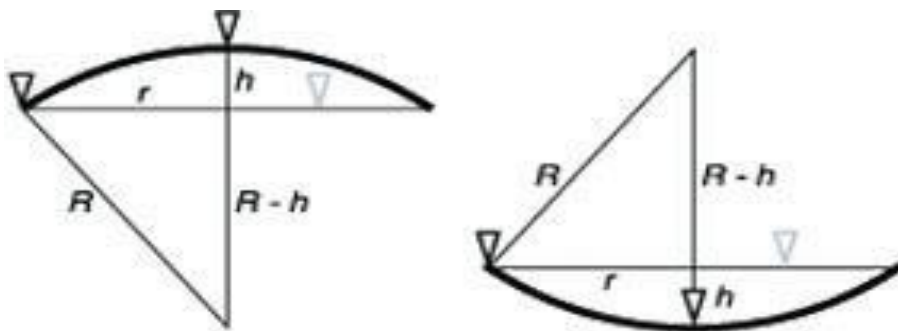

Figure 5.3 : Radius of curvature for convex and concave surface

Procedure:

1. Note the value of one division on the vertical scale/pitch scale.
2. Note the total no. of divisions on the circular scale.
3. Determine the pitch and least count of the spherometer.
4. Place the spherometer on the base plate so that all the three legs touch its surface.
5. Lift the spherometer and put it on a plain paper, press it slightly to get the impression of the three legs. Joint the markings to complete an equilateral triangle. Measure the length of its sides, carefully and note them down in table1. Repeat the procedure with two more orientations. Calculate the average distance between the two legs. Note it as ' d '
6. Then place the spherometer with the central screw raised and the three legs touching the curved surface. Take care to place the legs in such a way that the legs are on a horizontal plane.
7. Rotate the central screw gently till it touches the spherical surface. To be sure that the screw touches the surface, one can observe its image formed due to reflection from the surface beneath it.
8. Note the reading on the circular scale which touches the vertical scale/pitch scale. Note it as initial circular scale reading (ICSR).
9. Remove the curved surface and slowly rotate the circular scale to move the screw downward. Keep counting the no. of complete notations (N). Put it in table 2.

10. Note the reading on circular scale which touches the pitch scale. Note it down as final circular scale reading (FCSR).
11. Find the difference $D = I - F$
 - i. If $ICSR > FCSR$, Then, $D = ICSR - FCSR$
 - ii. If $ICSR < FCSR$, Then, $D = (ICSR + \text{total no. divisions on circular scale}) - FCSR$
12. Calculate Pitch Scale reading (PSR) using

$$PSR = \text{Pitch} \times \text{No. of complete rotation}$$
13. Calculate Circular Scale Reading using

$$CSR = \text{Difference} \times \text{least count (LC)}$$
14. The height h is the sum of PSR and CSR.

Calculate the radius of curvature.

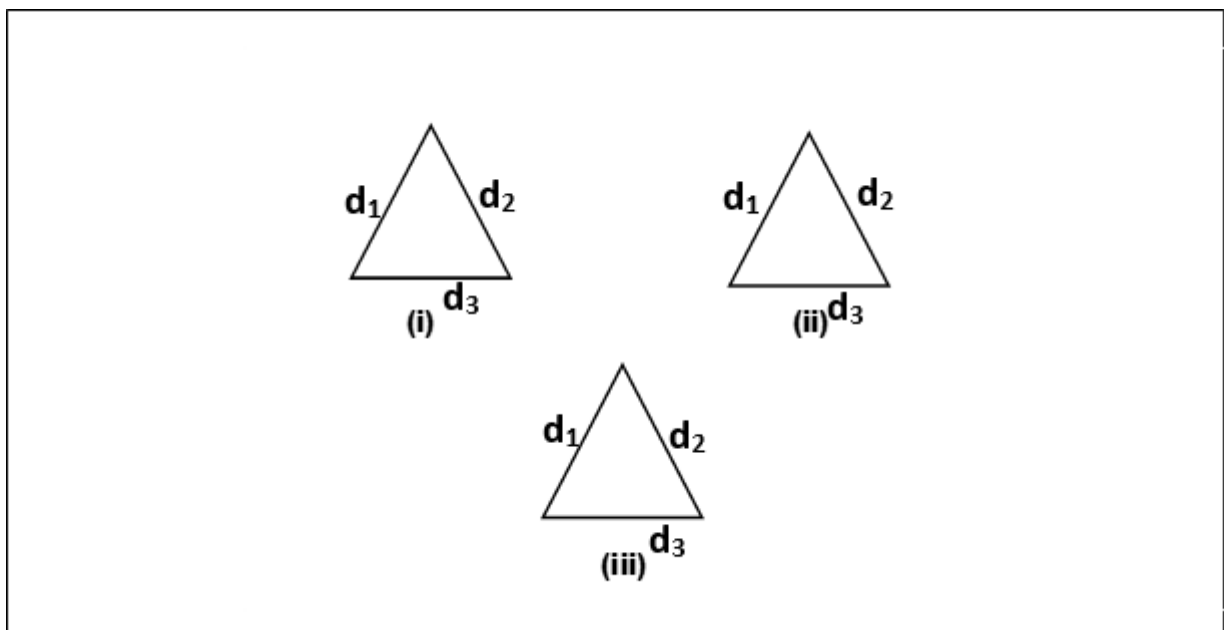

Figure 11: impression of the three legs of the spherometer form an equilateral triangle.

Observation:

Total no. of divisions on the circular scale = _____

The distance covered on the linear scale with 10 complete rotation of circular scale = _____ cm

The distance covered on the linear scale with 1 complete rotation of circular scale = _____ cm

So, Pitch = _____ cm

and LC = _____ cm

TABULATION-1 : MEAN DISTANCE BETWEEN THE CONSECUTIVE LEGS:

Sl. No.	Figure No.	d ₁ in cm	d ₂ in cm	d ₃ in cm	d=(d ₁ +d ₂ + d ₃)/3 in cm	Mean d in cm
1	I					
2	II					
3	III					

TABULATION 2 FOR THE MEAN HEIGHT h OF THE CONVEX SURFACE:

Sl. No.	PITCH	LC	ICSR	N	FCSR	Difference D = I ~ F	PSR = Pitch x N in cm	CSR = D x LC in cm	h = PSR+CSR in cm	Mean h in cm
21.										
22.										
23.										
24.										
25.										
26.										
27.										
28.										
29.										
30.										

Calculation:

The distance between the legs = $d =$ _____ cm

The height of convex surface = $h =$ _____ cm

$$\text{So, } R = \frac{d^2}{6h} + \frac{h}{2} = \text{_____ cm}$$

Conclusion:

The radius of curvature of the convex glass piece was estimated to be _____ cm.

Precautions:

1. The screw should not be rotated after the screw touches the curved surface.
2. The screw should be rotated in same direction.
3. The spherometer should sit on a horizontal plane of the curved surface.
4. The initial reading is to be taken on a higher surface so that to take the final reading the central leg is always lowered.

REVIEW QUESTIONS ON EXPERIMENT NO -5

Q1. Define radius of curvature.

Ans: The radius of curvature is the radius of the sphere from which the curve glass was cut.

Q2. Are the radius and radius of curvature of the spherical surface same?

Ans: No

Q3. Why the instrument is named as spherometer?

Ans: Because it is used to determine the radius of curvature of a spherical surface.

Q4. What is the radius of curvature of a plane surface?

Ans: Infinity.

EXPERIMENT NO : 6

Date:

To determine the radius of curvature of concave surface using a Spherometer.

Aim of the experiment:

To determine radius of curvature of a concave surface using spherometer.

Apparatus Required:

1. Spherometer
2. The concave piece of glass
3. Base Plate
4. Instrument box

Theory:

The theory remains same as that of experiment no. 5. It should be written again in the Lab report by the student.

Procedure:

1. Note the value of one division on the vertical scale/pitch scale.
2. Note the total no. of divisions on the circular scale.
3. Determine the pitch and least count of the spherometer.
4. Place the spherometer on the base plate so that all the three legs touch its surface.
5. Lift the spherometer and put it on a plain paper, press it slightly to get the impression of the three legs. Joint the markings to complete an equilateral triangle. Measure the length of its sides, carefully and note them down in table 1. Repeat the procedure with two more orientations. Calculate the average distance between the two legs. Note it as ' d '
6. Note the reading on the circular scale which touches the vertical scale/pitch scale when the central leg touches the base plate. Note it as initial circular scale reading (ICSR).
7. Now lift the spherometer. Keep it undisturbed (hold it with the metallic frame). Place it on the concave surface. Make sure the legs form a horizontal plain.
8. Slowly rotate the screw downward. Keep counting the no. of complete rotations (N). Put it in table 2.
9. Note the reading on circular scale which touches the pitch scale. Note it down as final circular scale reading (FCSR).

10. Find the difference $D = ICSR \sim FCSR$

a. If $ICSR > FCSR$, Then, $D = ICSR - FCSR$

b. If $ICSR < FCSR$,

Then, $D = (ICSR + \text{total no. divisions on circular scale}) - FCSR$

11. Calculate Pitch Scale reading (PSR) using

$$PSR = \text{Pitch} \times \text{No. of complete rotation}$$

12. Calculate Circular Scale Reading using

$$CSR = \text{Difference} \times \text{least count (LC)}$$

13. The height h is the sum of PSR and CSR.

14. Calculate the radius of curvature.

Working Formula:

$$R = \frac{d^2}{6h} + \frac{h}{2}, \text{ d= distance between consecutive legs of spherometer}$$

h= Height of concave surface

R= Radius of Curvature of Concave Surface

Observation:

Total no. of divisions on the circular scale = _____

The distance covered on the linear scale with 10 complete rotation of circular scale = _____ cm

The distance covered on the linear scale with 1 complete rotation of circular scale = _____ cm

So, Pitch = _____ cm

and LC = _____ cm

TABULATION-1 : MEAN DISTANCE BETWEEN THE CONSECUTIVE LEGS:

Sl. No.	Figure No.	d ₁ in cm	d ₂ in cm	d ₃ in cm	d=(d ₁ +d ₂ + d ₃)/3 in cm	Mean d in cm
1	I					
2	II					
3	III					

TABULATION 2 FOR THE MEAN HEIGHT h OF THE CONCAVE SURFACE:

Sl. No.	PITCH	LC	ICSR	N	FCSR	Difference D = I ~ F	PSR= Pitch x N in cm	CSR = D x LC in cm	h = PSR+CSR in cm	Mean h in cm
31.										
32.										
33.										
34.										
35.										
36.										
37.										
38.										
39.										
40.										

Calculation:

The distance between the legs = $d =$ _____ cm

The height $h =$ _____ cm

$$R = \frac{d^2}{6h} + \frac{h}{2} = \text{_____ cm}$$

Conclusion:

The radius of curvature of the Concave glass piece was found to be _____ cm.

Precautions: same as the ones in experiment no. 6.

LEARNING OUTCOMES:

- 1. The student will be able to understand the concept of gravity.**
- 2. The student will know the concept of simple harmonic oscillation and simple pendulum.**
- 3. The student will be able to estimate the value of 'acceleration due to gravity'.**

EXPERIMENT NO. 7

Date:

To find the time period of a simple pendulum and determine acceleration due to gravity.

Aim of the Experiment:

To find the time period of a simple pendulum and determine the acceleration due to gravity.

Apparatus Required:

1. A solid metallic bob with a hook
2. A long, inextensible string
3. Meter Scale
4. A split cork
5. Slide Calliper
6. Stop Watch
7. Clamp Stand
8. Instrument Box

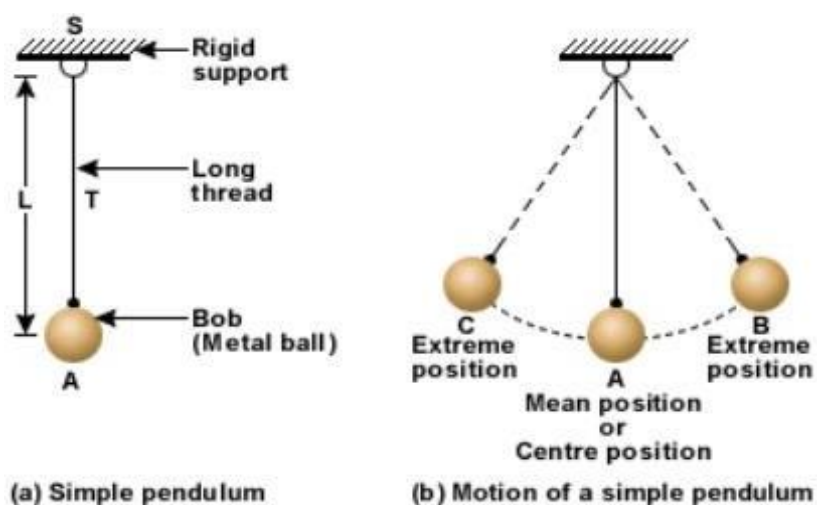

Figure 7.1

Theory:

A simple pendulum is an idealized physical system which consists of a heavy point mass suspended from a rigid support with a weightless, inextensible string . The system oscillates under the influence of gravity and the air resistance is neglected. The real simple pendulum consists of a heavy spherical bob suspended by a long string using a clamp stand and split cork.

The expression for time period of a simple pendulum is given by,

$$T = 2\pi\sqrt{\frac{L}{g}}$$

Working Formula :

$$g = 4\pi^2 \frac{L}{T^2} ,$$

g = Acceleration due to gravity

T = Time period of the simple pendulum= Time taken by the pendulum to complete one complete oscillation, which can be the time taken by the pendulum to start at one maximum, travel to the another and to come back to the same maximum.

L= Effective length of simple pendulum = The distance from the point of suspension to the centre of gravity of the bob.

So, ***the effective length is = length of string (l) + length of the hook (h) + radius of the bob (r)*** = $l + h + r$

Procedure:

1. Measure the diameter of the spherical bob using a slide calliper. Calculate its radius.
2. Then measure the height of the hook. This is done by measuring the (2r+h) and then subtracting 2r.
3. Tie the thread to the hook and stretch the thread tightly along the scale and tied end at its zero.
4. Put ink mark at fixed length like 30 cm, 35 cm..... 75 cm.
5. Suspend the pendulum from the clamp stand by putting the thread inside the split cork. Make sure the ink mark is at the bottom surface of the cork.
6. Hang the pendulum vertically, keep the thread parallel to the table edge. Draw a line on the table edge parallel to the string.
7. Draw two more lines which should not be crossed so that the angular displacement remains small.
8. Now, oscillate the pendulum in a vertical plane.
9. For a given effective length, note down the time taken for 20 oscillation using a stop watch. Repeat it two more times for better accuracy.

10. Change the effective length and follow procedure point 9.
11. Plot $L \sim T^2$ on a graph paper.

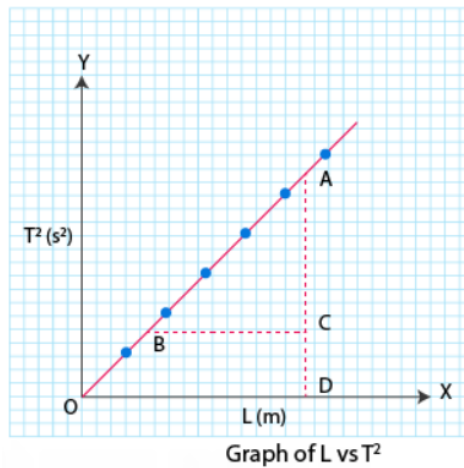

Figure 7.2 : typical plot between effective length and square of time period

12. Determine the slope of the graph.
13. Calculate the value of g .

Observation:

TABULATION -1 (FOR DIAMETER $2r$ OF THE METALLIC BOB)

No. of obs.	L.C	MSR in cm	VC	VSR = VC×LC in cm	Observed diameter MSR+VSR in cm	Zero Error in cm	Corrected diameter in cm	Mean Diameter of bob in cm ($2r$)
1.								
2.								
3.								
4.								
5.								

TABULATION -2 (FOR MEASUREMENT OF $2r+h$ OF THE METALLIC BOB)

Sl. No.	L.C in cm	MSR in cm	VC	VSR = VC×LC in cm	Observed $2r+h$ in cm	Zero error in cm	Corrected $2r+h$ in cm	Mean $2r+h$ in cm

Tabulation -3 (MEASUREMENT OF TIME PERIOD T AND L/T²)

Sl. No	Length of string (l) in cm	Effective length L= l+r+h in cm	Time for 20 oscillations in sec				T = t/20 in sec	T ² in sec ²	L/T ² in cm/sec ²	Mean L/T ² in cm/sec ²
			t ₁	t ₂	t ₃	t = (t ₁ + t ₂ + t ₃)/3				

Calculation:

Inverse of the slope of the graph = L/T² = _____ cm/sec²

From Tabulation - 3, L/T² = _____ cm/sec²

Mean L/T² = _____ cm/sec²

Hence, g = 4π² / T² = _____ cm/sec²

Conclusion:

The value of acceleration due to gravity was estimated to be _____ cm/sec² or _____ m/sec² by using a simple pendulum.

Precaution:

1. The oscillation should happen in a vertical plane.
2. The amplitude should be small.
3. Time period should be measured carefully.
4. Care must be taken so that the system does not get disturbed. In particular, disturbance due to vibration or wind should be avoided.

REVIEW QUESTIONS ON EXPERIMENT NO- 7

Q1. What is the difference between Gravity and acceleration due to gravity?

Answer: Gravity is the force with which the body is attracted towards the centre of the earth while acceleration due to gravity is the acceleration produced due to gravity

Q2. How does 'g' vary with height, depth or due to rotation of the earth about its axis?

Answer: It decreases with height, with depth and due to rotation of the earth.

Q3. Define simple harmonic motion?

Answer: It is the periodic motion in which acceleration is proportional to the displacement and is always directed towards the mean position.

Q4. What is simple pendulum? Who discovered it?

Answer: simple pendulum is defined as a heavy mass suspended by a weightless, inextensible and perfectly flexible string, Galileo discovered it.

Q5. What is Second's pendulum?

Answer: Pendulum whose time period two seconds, is called seconds pendulum

Q6. Does the time period of a simple pendulum depend upon mass, size and material of the bob?

Answer: No, the time period is independent of the mass, size and nature of the material of the bob.

Q7. Can we use a conical or cylindrical bob instead of spherical one?

Answer: Yes: it can be used but spherical bob is always preferred because it is easier to locate its centre of gravity.

Q8. How does 'g' vary from place to place on the surface of earth?

Answer. It is minimum at the equator, goes on increasing as we go towards the poles and is maximum at the poles

Q9. What will be the weight of the body at centre of the earth?

Answer. The weight of the body will be zero there because 'g' is zero at the centre of the earth.

LEARNING OUTCOMES:

1. Students will be able to understand the concept of prism.
2. The student will learn about prism and the concept of refraction.
3. The student will be able to determine the angle of prism.

EXPERIMENT NO - 8

Date:

To determine the angle of Prism.

Aim of the experiment:

To determine the angle of the given prism.

Apparatus Required:

1. Drawing Board.
2. White sheet of paper
3. Fixing Pins
4. Needle point steel pins
5. Pencil
6. Scale
7. Protractor
8. A triangular prism.

Theory:

Prism is an optical element with polished and flat surfaces which refract light. The surface should be angled. Two parallel surfaces do not constitute a prism. The conventional geometrical shape of an optical prism is that of a triangular prism with a triangular base and rectangular sides, and in general use of "prism" refers to this type. Prisms can be made from any material that is transparent to the wavelengths for which they are designed. Typical materials include glass, fluorite and plastic.

A prism can be used to disperse white light up into its constituent colours (wavelength). Furthermore, prisms can be used to reflect or refract light, or to split light into components with different polarization.

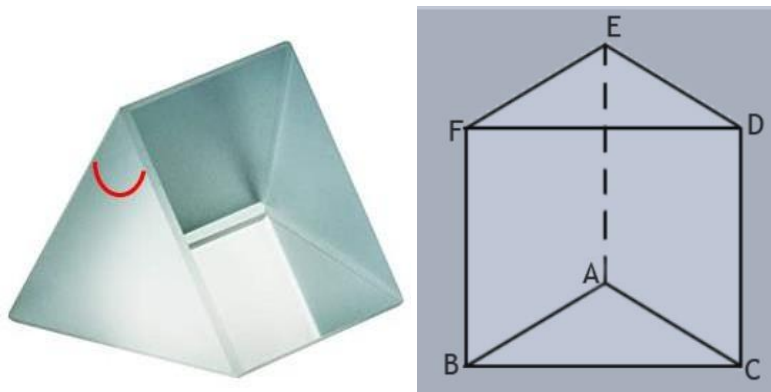

Figure 8.1: Image of a prism (left) and schematic of a prism (right)

In the left figure, the angle of prism is marked. In the right hand figure, the angle A between the two refracting surfaces ABFE and ACDE is called the angle of prism.

When a parallel beam of light is incident on a prism as shown in the below figure, then the angle of deviation is twice of the angle of prism. This principle is used to determine the angle of prism.

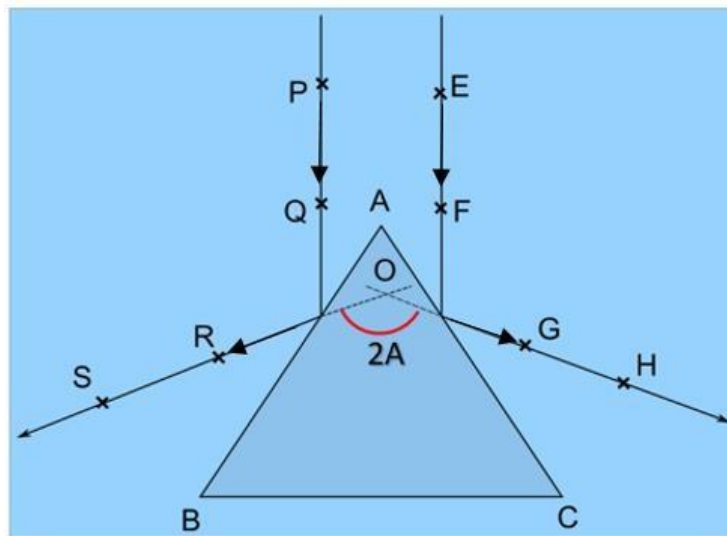

Figure 8.2: Reflection of parallel beam from the prism surface

Procedure:

1. Spread the white sheet of paper on the drawing board. Fix it using fixing pins.
2. Draw two parallel lines on the paper. Place the prism symmetrically on the two lines. Draw its outline triangle. Mark the vertices/corners as A, B, C
3. Put two pins on one of the parallel lines, say at P and Q. Make sure the pins stand straight. See their reflection inside the prism from the side AB and insert two more pins at R and S which lie along the line made by the tips of the images of the pins at P and Q. Avoid parallax error.

4. Now put two pins on the other parallel line, say at E and F. See its reflections from the side AC. Put two pins at G and H so that they lie in the same line as the images of the pins at E and F.
5. Remove the prism and pins. Mark the tips of the pins at P, Q, R, S, E, F, G and H. Join the line RS and GH.
6. RS and GH are the reflected ray. Extend the ray in the backward directions. Let them meet at O. Measure the angle ROG using protractor. Note it down in table 1. That is twice the angle of prism A.
7. Repeat the procedure from 2 to 6, for two more times.
8. Calculate the average 2A and then the angle of prism.

Observation:

Tabulation- 1: FOR ANGLE OF PRISM A

No. of Observations	2A in degrees	Mean value of 2A in degrees	Angle of prism (A) in degree
1.			
2.			
3.			

Conclusion:

The angle of prism was found to be _____ degree.

Precaution:

1. Ray direction should be marked.
2. The position of the pin must be marked with circle immediately after removing the pins.
3. The experiment table and board should be placed in a firm manner so that there is no disturbance due to vibration.
4. The pins must be fixed straight.
5. Parallax error should be avoided.

REVIEW QUESTIONS ON EXPERIMENT NO-8

Q1. What is a prism? Mention two uses of prism.

Prism is a three-dimensional transparent solid object in which the two ends are identical. It is the combination of the flat faces, identical bases and equal cross-sections. The faces of the prism are parallelograms or rectangles without the bases. The bases of the prism could be triangle, square, rectangle or any n-sided polygon. For example, a pentagonal prism has two pentagonal bases and 5 rectangular faces.

Q2. Can we say that glass slab is also a kind of prism?

No, the surfaces of the prism must be angled. Hence, a glass slab is not a kind of prism.

Q3. Define angle of prism.

Angle of prism is the angle between the two surfaces of the prism from which the light enters the prism and from the light goes out after refraction.

Q4. What is the principle for determination of angle of prism?

When two parallel rays of light are incident on the two surfaces of a prism, the angle between the two corresponding reflected rays is twice the angle of prism.

Q5. What are the laws of reflection?

There are two laws of reflections. First one is, the incident ray, the reflected ray and the normal to the reflecting surface lie in the same plane. The second law says, the angle of incidence is equal to the angle of reflection.

Q6. What is dispersion?

Dispersion is the separation of white light into its constituent wavelengths by a prism.

Q7. Define transparency with respect to a wavelength.

If the wavelength can pass through the optical object, then the optical object is transparent with respect to that wavelength.

LEARNING OUTCOMES:

1. The student will learn about prism.
2. The student will learn about refraction at the surfaces of prism, Snell's Law, refractive index and angle of deviation.
3. The student will be able to determine the refractive index of prism material.
4. The students will learn about dispersion through a prism, angle of deviation etc

EXPERIMENT NO. 9:

Date:

To determine the angle of Minimum Deviation by I ~ D curve method.

Aim of the Experiment:

To determine the angle of Minimum Deviation of the material of prism by I ~ D curve method.

Apparatus Required:

1. Drawing board
2. Drawing Sheet
3. Fixing pins
4. 04 nos. of hair pins
5. Scale, protractor, pencil
6. Prism

Theory:

When light travels from one medium to another medium, it gets refracted and enters the second medium at a different angle. The degree of bending of the light's path depends on the angle that the incident beam of light makes with the surface of the prism, and on the ratio between the refractive indices of the two media. This is called Snell's law.

$$\text{Mathematically, } \frac{\sin i}{\sin r} = \frac{\mu_2}{\mu_1} = \mu_{21}$$

Where, i = angle of incidence

r = angle of refraction

μ_1 = absolute refractive index of first medium

μ_2 = absolute refractive index of second medium

μ_{21} = relative refractive index of second medium w. r. t the first medium

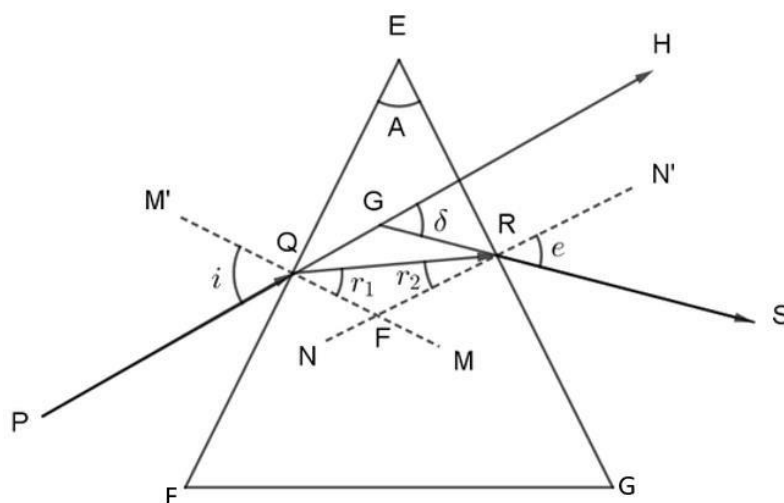

Fig. 9.1

When, light ray PQ is incident on the surface EF with angle of incidence i , it gets refracted by an angle r_1 , and travels along QR. The ray QR again suffers refraction at the surface EG, then emerges along RS with an e .

If the prism was not present, the ray PQ would have travelled along the direction PH instead of RS.

The angle δ between PH and GS is called the **angle of deviation**.

The angle of deviation is minimum when the angle of incidence = angle of emergence, i.e. $i = e$

At this condition, means, when $\delta = \delta_m$, the ray travelling inside the prism becomes parallel to the base of prism.

As the angle of incidence is increased, angle of deviation δ decreases and reaches minimum value. If the angle of incidence is further increased, the angle of deviation increase. The angle of minimum deviation can be obtained from the graph between angle of incidence and angle of deviation.

The refractive index of the prism μ material is given as

$$\mu = \frac{\sin\left(\frac{A + \delta_m}{2}\right)}{\sin\left(\frac{A}{2}\right)}$$

A = Angle of Prism

δ_m = Angle of Minimum Deviation

μ = Refractive Index of Prism

Procedure:

1. Fix the sheet on the drawing board with fixing pins, properly.
2. Draw a long straight line in the middle of the paper.

- Keep therefracting surface of prism on this line, draw its outline.
- AB is the first refracting surface.
- Draw a Normal N_1 to AB. Draw the incident ray PO_1 which makes an angle $i_1 = 30^\circ$ with the normal.

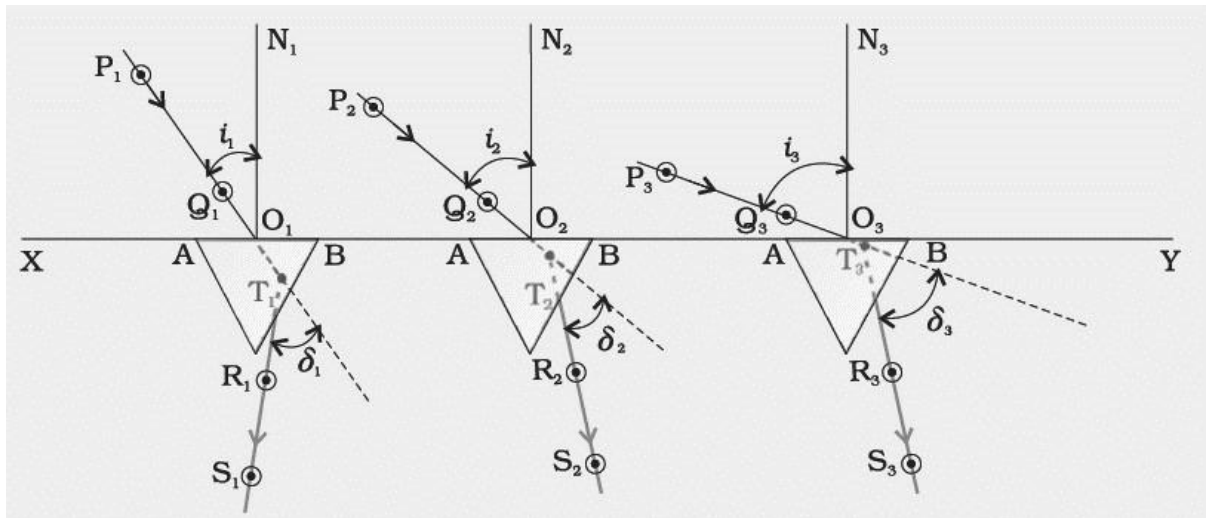

Fig.9.2

- Put two pins on the incident ray at P_1 and Q_1 . See their image inside the prism from the other refracting surface.
- Put two pins which lie in the same line as the images. Mark their position as R_1 and S_1 .
- Remove the prism and the pins. Encircle all the tip of the pin. Draw the emergent ray by joining R_1 and S_1 .
- Extend both P_1Q_1 and R_1S_1 so that they meet at T_1 .
- Note down the angle of incidence and angle of deviation in table 1.
- Now place the prism at another place of the line. Repeat the procedure from 3 to 10 for the angles of incidence = 35° , 40° , 45° , 50° , 55° , 60° .
- Draw the graph between angle of incidence versus angle of deviation. The plot looks like the below figure.

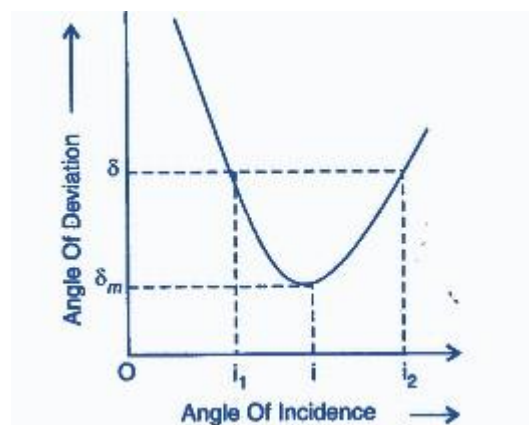

Figure 9.3: Representative plot of angle of deviation versus angle of incidence

- Mark the angle of minimum deviation δ_m . Note the corresponding angle of incidence.
- Use the formula to calculate the refractive index of the prism material.

Observation:**TABULATION-1: (I~D AND DETERMINATION OF ANGLE OF MINIMUM DEVIATION FROM GRAPH)**

No. of observation	Angle of incidence in degree (i)	Angle of deviation in degree (D)	Angle of minimum deviation from graph (δ_m)
1.	30		
2.	35		
3.	40		
4.	45		
5.	50		
6.	55		
7.	60		

Calculation:

The angle of minimum deviation was found to be $\delta_m =$ _____ degree

Conclusion:

The angle of minimum deviation of the prism material was found to be _____.

Precaution:

1. Pins should be fixed perfectly vertical.
2. While fixing the pins in line with the refractive images of incident rays care should be taken for the parallax error.
3. There should be some space between the pins.
4. Pins should not be disturbed during the experiment.
5. Same edge of the prism should be taken as vertex A for all the observations.
6. Clean both the faces AB and AC of the prism proper before taking the readings.

REVIEW QUESTIONS FROM EXPERIMENT NO. 9

Q1. Define refraction.

Ans: Refraction is the bending of light at the interface of two transparent optical media.

Q2. Define angle of incidence and angle of refraction.

Ans: The angle between the incident ray and the normal to the refracting surface is called angle of incidence.

The angle between the normal to the refracting surface and the refracted ray is called angle of refraction.

Q3. Define absolute refractive index.

Ans: The ratio of the speed of light in vacuum to speed of light in a medium is called as absolute refractive index of the medium.

Q4. Define relative refractive index.

Ans: When we measure speed of light in two different media, **relative refractive** index of medium 2 with respect to medium 1 is defined as the ratio of speed of light in medium 1 to speed of light in medium 2.

Q5. What is the speed of light in vacuum?

Ans: $3 \times 10^8 \text{ m/s}$

Q6. Define wave velocity?

Ans: The total distance covered by a wave in unit time is called wave velocity.

Q7. Is light a wave? If yes, what is its type?

Ans: Light has both wave and particle nature. Light is an electromagnetic wave.

Q8. Define angle of deviation in the case of refraction through prism.

Ans: In the absence of a prism, a light ray will continue in a straight line. However, in the presence of a prism, the light ray will suffer refraction at the two surfaces of prism.

The angle between the incident ray and the emergent ray after the two refractions at the prism surfaces is called angle of deviation.

Q9. How does angle of deviation vary with angle of incidence?

Ans: The angle of deviation decreases with increase in angle of incidence, reaches a minimum and then increases.

Q10. What are the conditions for minimum deviation?

Ans: When the condition of minimum deviation is satisfied, the angle of incidence is equal to angle of emergence. And the refracted ray inside the prism is parallel to the base of the prism.

Q12. What is the formula for refractive index in terms of angle of prism and angle of minimum deviation?

Ans.

$$\mu = \frac{\sin \left(\frac{A + \delta_m}{2} \right)}{\sin \left(\frac{A}{2} \right)}$$

where A = angle of prism

δ_m = angle of minimum deviation

LEARNING OUTCOMES:

1. The student will get an idea about magnetic poles, magnetic field and the lines of force.
2. The student will know about the geomagnetic field.
3. The student will be able to draw lines of force.
4. The student will know how to locate the neutral point.

EXPERIMENT NO. 10

Date:

Tracing of lines of forces due to a bar magnet with north pole pointing geographic north pole of earth

Aim of the Experiment:

To trace lines of force due to a bar magnet with North pole pointing North and locate the neutral points.

Apparatus Required:

1. Drawing board
2. Drawing Sheet
3. Pencil, scale
4. Bar magnet
5. Compass needle
6. Fixing pins

Theory:

A magnet has two poles - one south pole and a north pole. Like poles repel and unlike poles attract each other.

Earth is a giant magnet. Earth's magnetic field is defined by north and south poles representing lines of magnetic force flowing into the Earth in the northern hemisphere and out of Earth in the southern hemisphere. At the north and south poles, the force is vertical. The force is horizontal at the equator.

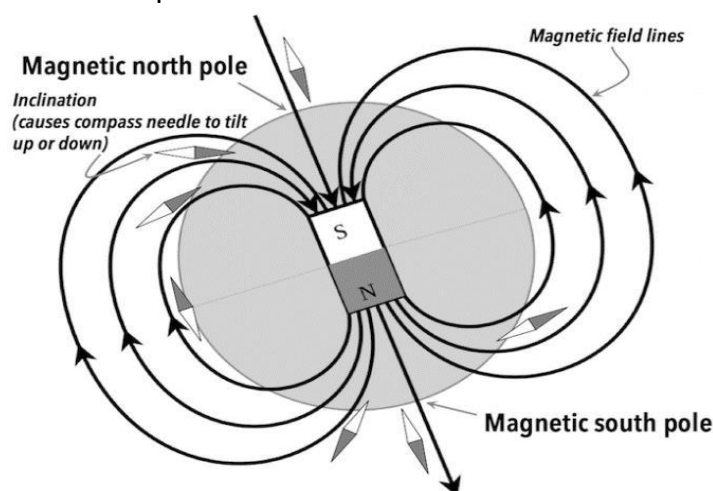

Figure 10.12: The magnetic field associated with the earth and a bar magnet.

The south pole of the magnet points to Earth's magnetic north pole and the north pole of a magnet points towards the magnetic South Pole of the earth.

Magnetic lines of forces are the closed imaginary curve starting from the North Pole and ending in the South Pole in a magnetic field such that the tangent drawn at any point on the curve gives the direction of the resultant magnetic field at that point. The density of magnetic field lines indicate the field strength in an area.

A **neutral point** of Magnet is a **point** at which the resultant magnetic field is zero. At neutral point, the field due the bar magnet is equal and opposite of the Earth's magnetic field. So, if a compass needle is placed at this point, then it will tend to remain in the direction in which it is kept.

Neutral points are located symmetrically with respect to the magnet on the equatorial of the magnet when the North Pole points north.

Neutral points are located symmetrically with respect to the magnet on the axial line of the magnet when its north pole points south.

Procedure:

1. Spread the paper on the drawing board. Fix it well.
2. Keep the compass needle in the middle of the paper. Mark the geographic north and south indicated by the pointing arrow by putting dots next to the needle. Join the two dots to draw a line and extend it.
3. Place the bar magnet in the middle of the paper. Trace its outline. Keep the North Pole (marked by a small hole, in general) of the magnet towards the geographic north of Earth and the South Pole towards south.
4. Place the magnetic needle near the north pole of the magnet. Let its arrow rest.
5. Put two dot marks on the paper corresponding to the position of both end of the needle. Place the needle at the subsequent position in such a way that one end of it coincides with the previously marked dot.
6. Mark the other end with dot. Continue this till you reach the South Pole. Connect the dots with smooth curves.
7. Then again place the needle at a different place near the North Pole. Continue the procedure 4 to 6.
8. Continue the process till a series of curves/lines of force are obtained between the two poles.
9. Draw lines of force on both the sides of the magnet, symmetrically.
10. Place the magnetic compass on the equatorial axis of the magnet. Move it slowly away from the magnet. Check if the compass is experiencing any magnetic force. This can be checked by rotating the compass and seeing if the arrow of compass is pointing to a particular direction or random directions. At neutral point the arrow of the compass rotates with rotation of the compass.
11. Locate the neutral points on both the sides of the magnet. Trace the outline of the compass and put cross insides.
12. The picture looks like this.

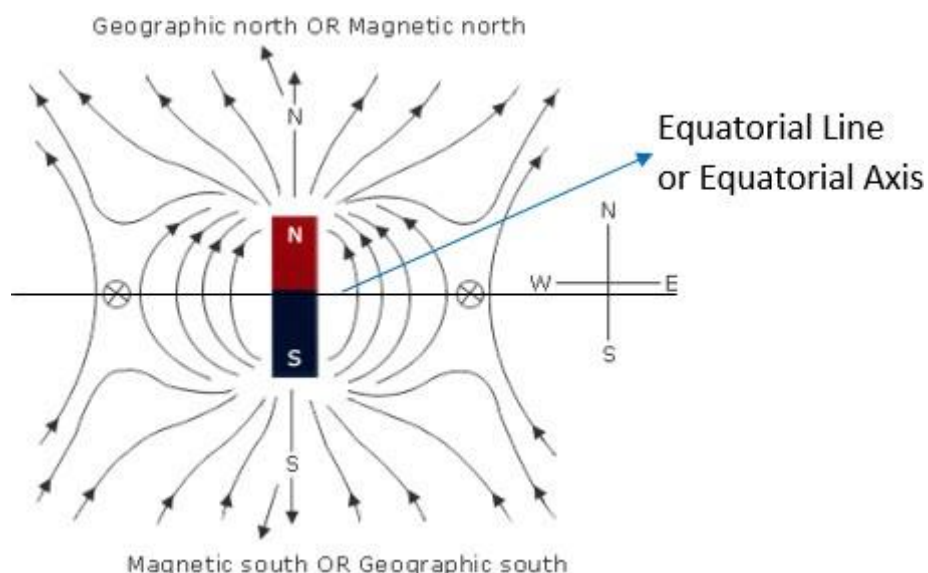

Figure 30.2: A representative picture of magnetic lines of force associated with the bar magnet with its north pole pointing geographic north.

Observation:

Both the neutral points on either side should be generally equidistant from the centre of Bar magnet

Conclusion:

- The magnetic lines of forces of a magnet were drawn with its north pole pointing north.
- The lines of force do not intersect each other.
- The neutral points are located on the equatorial line of the magnet at a distance of _____cm

Precautions:

1. Don't rely on the painted arrows on the pointers in the compass to tell which pole is north and which is south; they don't all use the same convention. Make sure the pointers can rotate freely.
2. Keep the bar magnet far away while determining the geographic north south/drawing the axial line using the magnetic compass.
3. The table should be away from other magnet, magnetic material or electric circuit.
4. The position of magnet should not get changed.
5. The direction of lines of force should be marked.
6. The neutral point should be determined properly.

REVIEW QUESTIONS ON EXPERIMENT NO - 10

Q1. Define magnetic lines of force.

Ans: The imaginary lines drawn around a magnet in such a way that the tangent drawn at any point of the line would show the direction of the field at that point. The density of field lines i.e., the no. of lines per unit area represents the field strength in that area. The field line originates from north pole and enters the south pole outside the magnet and directs from south to north pole inside the magnet. Two magnetic lines of force never intersect each other.

Q2. Define neutral point in a magnetic field.

Ans: Neutral point is a point at which resultant magnetic field is always zero. The horizontal component of earth's field is balanced by the magnet's field.

Q3. Why do not two magnetic lines of force do not intersect each other.

Ans: If two magnetic lines of force intersect at the point of intersection, then there would be two tangents and hence, the direction of magnetic field would not be defined.

Q4. How do the magnetic lines of force look like in a uniform magnetic field?

Ans: They are represented as parallel lines.

Q5. Does monopole exist?

Ans: No, monopole does not exist.

Q6. What is the magnetic force between two magnetic poles?

Ans: The magnetic force is $F = \frac{\mu_0 m_1 m_2}{4\pi r^2}$, where μ_0 = permeability of free space, m_1, m_2 - pole strengths, r = distance between the two poles.

Q7. Why does the compass needle align itself in a particular direction?

Ans. Due to earth's magnetic field

Q8. If a magnet is suspended in air via a light string, towards which direction its north pole will point?

Ans: Towards the south pole of earth.

Q9. Can we get a north pole and a south pole by breaking a bar magnet?

Ans: No, we cannot.

EXPERIMENT NO. 11

Date:

Tracing of lines of forces due to a bar magnet with north pole pointing geographic south pole of earth

Aim of the Experiment:

To trace lines of force due to a bar magnet with North pole pointing south and locate the neutral points.

Apparatus Required:

1. Drawing board
2. Drawing Sheet
3. Pencil, scale
4. Bar magnet
5. Compass needle
6. Fixing pins

Theory:

For writing theory please refer experiment no. 10.

Procedure:

1. Spread the paper on the drawing board. Fix it well using fixing pins.
2. Keep the compass needle in the middle of the paper. Mark the geographic north and south indicated by the pointing arrow by putting dots next to the needle. Join the two dots to draw a line and extend it.
3. Place the bar magnet in the middle of the paper. Trace its outline. Keep the North Pole (marked by a small hole, in general) of the magnet towards the geographic south of Earth and the South Pole towards north.
4. Place the magnetic needle near the north pole of the magnet. Let its arrow rest.
5. Put two dot marks on the paper corresponding to the position of both end of the needle. Place the needle at the subsequent position in such a way that one end of it coincides with the previously marked dot.
6. Mark the other end with dot. Continue this till you reach the South Pole. Connect the dots with smooth curves.
7. Then again place the needle at a different place near the North Pole. Continue the procedure 4 to 6.
8. Continue the process till a series of curves/lines of force are obtained between the two poles.
9. Draw lines of force on both the sides of the magnet, symmetrically.
10. The picture looks like this.

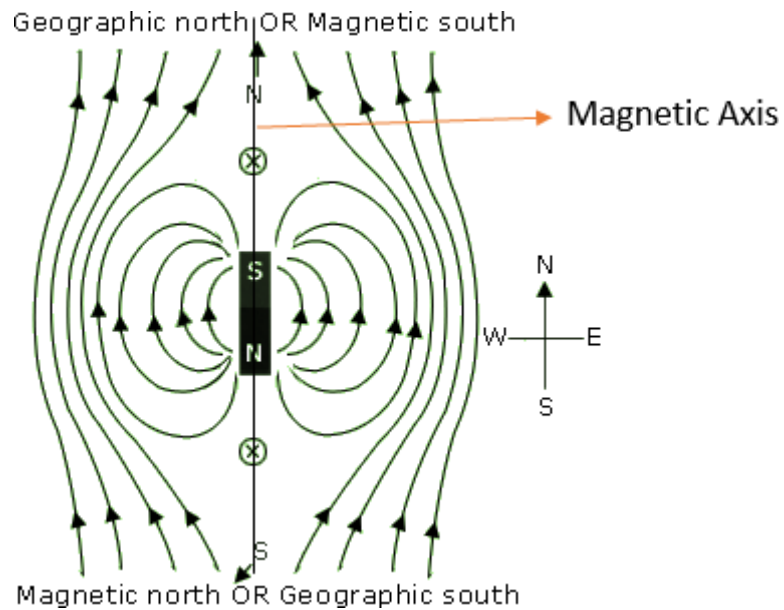

Figure 4: Magnetic lines of forces due to bar magnet with north pole pointing geographic south

11. Place the magnetic compass on the axial line of the magnet. Move it slowly away from the magnet. Check if the compass is experiencing any magnetic force. This can be checked by rotating the compass and seeing if the arrow of compass is pointing to a particular direction or a random directions. At neutral point the arrow of the compass rotates with rotation of the compass.
12. Locate the neutral points on both the sides of the magnet. Trace the outline of the compass and put cross inside.

Observation:

Both the neutral points on either side should be generally equidistant from the centre of Bar magnet.

Conclusion:

- The magnetic lines of forces of a magnet were drawn with its north pole pointing south.
- The lines of force do not intersect each other.
- The neutral points are located on the axial line of the magnet at a distance of _____ cm

Precautions:

The precautions are same as the ones in experiment no. 10.

REVIEW QUESTIONS ON EXPERIMENT NO-11

Q1. How can you determine neutral point?

Ans. To determine the neutral point in the magnetic field of a bar magnet with its north pole pointing geographic south of earth, the compass needle is slowly moved along the magnetic axis. When the neutral point is reached, the needle rotates freely along with the rotation of the compass and does not point in a particular direction.

Q2. Are the neutral points equidistant from magnetic poles?

Ans. Yes, the neutral points are equidistant from the magnetic poles.

Q3. Does the line joining neutral points coincide with the axis of the bar magnet?

Ans. Yes, the line joining the neutral points coincides with the axis of the bar magnet when the north pole of the bar magnet is placed pointing towards geographic south of the Earth.

Q4. What happened to the magnet if the magnet is slightly rotated?

Ans. The magnet will come back to a position where the magnetic axis is along the north-south direction of the earth, if it is free to do so.

Q5. Why two magnetic lines of force never intersect each other?

Ans. The magnetic lines of force never intersect each other because if they do so it would imply two directions of magnetic field at the point of intersection.

Q6. Why we use very short magnetic needle but not a large compass needle?

Ans. The magnetic field around a bar magnet is not uniform. Hence, with a small magnetic needle, the field strength around its ends will not be very different and will point along the tangent to magnetic lines. However, that would not be the case with a large compass needle. Hence, a proper tracing of magnetic field lines, use of small compass needle is essential.

Q7. What do you mean by magnetic meridian and geographic meridian?

Ans. The magnetic meridian is an imaginary plane passing through the magnetic south and north pole. A compass needle is parallel to the magnetic meridian.

The vertical plane passing through the geographic north and south pole of earth is called the geographic meridian.

LEARNING OUTCOMES:

1. The student will be able to define ohm's law.
2. The student will know the concept of resistance, current, voltage, ammeter, voltmeter and rheostat.
3. The student will know how to measure potential difference by voltmeter.
4. The student will be able to measure current by ammeter.
5. The student will know how to calculate resistance of a given conductor.

EXPERIMENT NO. 12

Date

Verification of the Ohm's Law

Aim of the experiment:

To verify Ohm's Law by Ammeter - Voltmeter method.

Apparatus Required:

1. A battery
2. Pieces of insulated copper wire
3. Sand paper
4. Ammeter
5. Voltmeter
6. Rheostat
7. Resistor
8. key

Theory:

Statement of Ohm's Law: The potential difference 'V' across the two ends of a given conductor in an electric circuit is directly proportional to the current 'I' flowing through it provided the temperature is constant.

Mathematically, V a I, So, V = IR

Here, R is the proportionality constant and is known as resistance.

The SI unit of resistance is Ohm. The notation for Ohm is Ω .

The resistance offered by a wire is dependent on the nature of material, the length(l) of the conductor and its cross-sectional area (A).

$$R = \frac{\rho l}{A}$$

Here, ρ (rho) is the resistivity of the material.

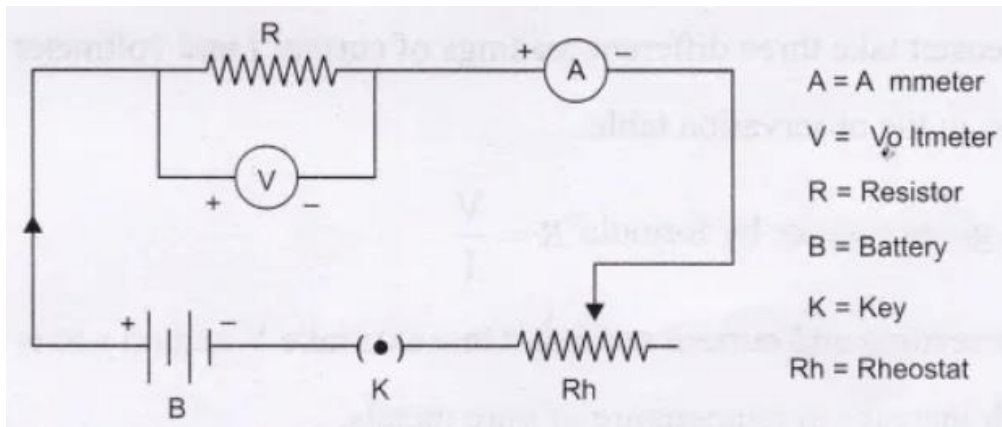

Figure 5: Circuit diagram for the verification of Ohm's Law

- In a circuit ammeter is connected in series.
- The voltmeter is connected in parallel across the points between which potential difference is to be measured.
- A straight line graph obtained between V and I verifies the Ohm's law.

Procedure:

1. Determine the least count of the ammeter and voltmeter by noting down its range and the total no. of divisions on them.
2. Check for zero error. It should be adjusted prior to commencement of experiment.
3. Remove the insulation from the end of the connecting copper wires using sand paper.
4. Connect the ammeter, battery, voltmeter, key and rheostat as per the circuit diagram.
5. Keep the key open.
6. In the circuit, connect the positive terminal of the ammeter to the positive terminal of battery.
7. Check the rheostat, adjust its slider and see whether the ammeter and voltmeter readings are shown.
8. When there is a constant flow of current in the resistor, note down the current and the corresponding potential difference.
9. Note down the values of potential difference in the voltmeter corresponding to the step by step increase of the current and then by decrease of the current by sliding the rheostat.
10. Calculate the resistance by taking the mean of potential Difference.
11. Plot a graph between the voltage and current with V on the X-axis. The slope of the graph gives the inverse of the resistance

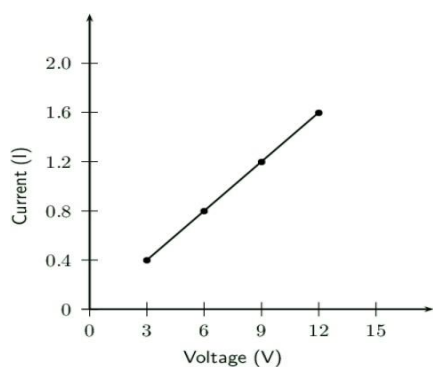

Fig.12.2

Observation:

TABULATION FOR V ~ I READING

Sl. No.	Ammeter Reading (I) in ampere	Voltmeter reading (V) in volts			V/I=R in Ohm	Mean R in Ohm
		Current Increasing	Current Decreasing	Mean		
1.						
2.						
3.						
4.						
5.						
6.						
7.						
8.						
9.						
10.						

Conclusion:

The ratio of V to I was seen to be constant in Tabulation - 1. The plot of V versus I passed through the origin. Hence, the Ohm's law is verified. The resistance as determined from the graph was _____ohm.

Precautions:

1. Connections should be tight otherwise some external resistance may introduce in the circuit.
2. The least counts of the ammeter and voltmeter should be estimated carefully.
3. The current should not be flown for a longer time, otherwise, it would increase the temperature and in turn would change the resistance of the resistor.
4. Current beyond 2 Amperes should be avoided.

REVIEW QUESTIONS ON EXPERIMENT NO. 12

Q1: What is the nature of the V-I graph?

Ans: A straight line.

Q2. What happens to current, when potential difference increases?

Ans: Increases

Q4. Define the terms current, potential difference.

Ans: Time rate of change of electric charge.

Potential difference: The difference in electrical potential between two points.

Q5. What is the role of voltmeter and Ammeter?

Ans: A voltmeter is an instrument used for measuring electrical potential difference between two points in an electric circuit. An ammeter is a measuring device used to measure the electric current in a circuit.

An ammeter is a measuring device used to measure the electric current in a circuit

Q6. What is resistance?

Ans: Resistance is a measure of the opposition to current flow in an electrical circuit

Q7. Why the voltmeter is to be connected in parallel to circuit?

Ans: A voltmeter measures the potential difference of the circuit and it has high internal resistance. When the voltmeter is connected in parallel with a circuit component, the amount of current passing through the voltmeter is very less.

Q8. Why the ammeter is to be connected in series to circuit?

Ans: In a series connection, the current flowing through all the components of the circuit is the same. Ammeter aims at measuring the current in the circuit, hence it is

Q9. What is the nature of V-I graph at variable temperature?

Ans: Non-linear

LIST OF REFERENCE BOOKS

1. Laboratory manual on Engineering Physics of 1st semester, developed by DTET, Odisha and S.C.T.E.V.T, Odisha
2. ISC Practical Physics (Class XI and XII), K. N. Sharma and M. N. Chanana, Kalyani Publisher
3. Practical Physics (Class XI and XII), A. Sharma, Modern's ABC