

ELECTRONICS MEASURING INSTRUMENTS

3RD SEMESTER-ETC

BY

PRABHAKAR RATH



CVRAMAN POLYTECHNIC

[CHAPTER-01]

QUALITIES OF MEASUREMENT

1. INSTRUMENT AND MEASUREMENT-

1. INSTRUMENT-

It is a device for determining values or magnitude of a quantity or variable through a given set of formulas.

2. MEASUREMENT-

It is a process of comparing an unknown quantity with an accepted standard quantity.

1.1. ELECTRONIC MEASUREMENT & INSTRUMENTATION-

It is the branch of Electronics which deals with the study of measurement and variations of different parameters of various instruments.

➤ *Why measurement of parameters and study of variations for a particular instrument are required?*

The measurement of parameters and its variations for a particular instrument is required because it helps in understanding the behaviour of an instrument.

1.2. CONDITION FOR A MEASURING INSTRUMENT:-

The measuring instrument must not affect the quantity which is to be measured.

2. MEASUREMENT SYSTEM PERFORMANCE:-

The performance of the measurement system/instruments are divided into two categories.

1. *Static Characteristics*
2. *Dynamic Characteristics*

2.1. STATIC CHARACTERISTICS OF INSTRUMENT-

These are those characteristics of an instrument which do not vary with time and are generally considered to check if the given instrument is fit to be used for measurement.

The static characteristics are from one form or another by the process called Calibration.

They are as follows:-

1. **ACCURACY-** *It is defined as the ability of a device or a system to respond to a true value of a measure variable under condition.*
2. **PRECISION-** *Precision is the degree of exactness for which an instrument is design or intended to perform.*
3. **REPEATABILITY-** *The repeatability is a measuring device may be defined as the closeness of an agreement among a number of consecutive measurements of the output for the same value of the input under save operating system.*
4. **REPRODUCIBILITY-** *Reproducibility of an instrument is the closeness of the output for the same value of input. Perfect reproducibility means that the instrument has no drift.*
5. **SENSITIVITY-** *Sensitivity can be defined as a ratio of a change output to the change input at steady state condition.*

6. RESOLUTION- Resolutions the least increment value of input or output that can be detected, caused or otherwise discriminated by the measuring device.
7. TRUE VALUE-True value is error free value of the measure variable it is given as difference between the Instrument Reading and Static error.
Mathematically,

$$\text{True value} = \text{Obtained Instrument reading} - \text{static error.}$$

Note- $\% \text{Error} = \frac{\text{Standard Reference Value} - \text{Obtained Reading}}{\text{Standard Reference Value}} * 100$

2.2. DYNAMIC CHARACTERISTICS OF INSTRUMENT-

The Dynamic Characteristics are those which change within a period of time that is generally very short in nature.

1. SPEED OF RESPONSE-It is the rapidity with which an instrument responds to the changes to in the measurement quantity.
2. FIDELITY-The degree to which an instrument indicate the measure variable without dynamic error.
3. LAG-It is retardation or delay in the response an instrument to the changes in the measurement.

2.3. ERROR- The deviation or change of the value obtained from measurement from the desired standard value.

Mathematically,

$$\text{Error} = \text{Obtained Reading/Value} - \text{Standard Reference Value.}$$

There are three types of error. They are as follows:-

1. GROSS ERRORS-This are the error due to humans mistakes such as careless reading mistakes in recoding observation incorrect application of an instrument.
- A. SYSTEMATIC ERROR-A constant uniform deviation of an instrument is as systematic error. There are two types of systematic error.
 - a) STATIC ERROR-
The static error of a measuring instrument is the numerical different between the true value of a quantity and its value as obtained by measurement.
 - b) DYNAMIC ERROR-
 1. It is the different between true value of a quantity changing with and value indicated by the instrument.
 2. The Dynamic Errors are caused by the instrument not responding fast enough to follow the changes in the measured value.
- B. RANDOM ERROR-The cause of such error is unknown or not determined in the ordinary process of making measurement.

2.3.1. TYPES OF STATIC ERROR-

- i. INSTRUMENTAL ERROR- Instrumental error are errors inherent in mastering instrument because of the mechanical construction friction is bearing in various moving component. It can be avoided by
 - a. Selecting a suitable instrument for the particular measurement.
 - b. Applying correction factor after determining the amount of instrumental error.

- ii. ENVIRONMENTAL ERROR–Environmental error are due to conditions external to the measuring device including condition al in the area surrounding the instrument such as effect of change in temperature , humidity or electrostatic field it can be avoided
 - a. Providing air conditioning.
 - b. Use of magnetic shields.

- iii. OBSERVATIONAL ERROR- The errors introduced by the observer. These errors are caused by habits of the observers like tilting his/her head too much while reading a “Needle – Scale Reading”.

CHAPTER-02

INDICATING INSTRUMENT

2.1. INTRODUCTION

2.1.1. MEASURING INSTRUMENTS:-

Measuring instruments are classified according to both the quantity measured by the instrument and the principle of operation.

There are three general principles of operation:

- electromagnetic, which utilizes the magnetic effects of electric currents;
- electrostatic, which utilizes the forces between electrically-charged conductors;
- Electro-thermic, which utilizes the heating effect.

The essential requirements of measuring instruments are:-

- It must not alter the circuit conditions.
- It must consume very small amount of power.

Electric measuring instruments and meters are used to indicate directly the value of current, voltage, power or energy.

An electromechanical meter (input is as an electrical signal results mechanical force or torque as an output) that can be connected with additional suitable components in order to act as an ammeters and a voltmeter.

The most common analogue instrument or meter is the permanent magnet moving coil instrument and it is used for measuring a dc current or voltage of an electric circuit.

2.1.2. TYPES OF FORCES/TORQUES ACTING IN MEASURING INSTRUMENTS:

1. DEFLECTING TORQUE/FORCE:

- The deflection of any instrument is determined by the combined effect of the deflecting torque/force, control torque/force and damping torque/force.
- The value of deflecting torque must depend on the electrical signal to be measured.
- This torque/force causes the instrument movement to rotate from its zero position.

2. CONTROLLING TORQUE/FORCE:

- This torque/force must act in the opposite sense to the deflecting torque/force, and the movement will take up an equilibrium or definite position when the deflecting and controlling torque are equal in magnitude.
- The Spiral springs or gravity usually provides the controlling torque.

3. DAMPING TORQUE/FORCE:

- A damping force is required to act in a direction opposite to the movement of the moving system.
- This brings the moving system to rest at the deflected position reasonably quickly without any oscillation or very small oscillation.

- This is provided by
 - i) Air friction
 - ii) Fluid friction
 - iii) Eddy current.
- It should be pointed out that any damping force shall not influence the steady state deflection produced by a given deflecting force or torque.
- Damping force increases with the angular velocity of the moving system, so that its effect is greatest when the rotation is rapid and zero when the system rotation is zero.

2.2. BASIC METER MOVEMENT & PMMC MOVEMENT

2.2.1. BASIC METER MOVEMENT OR D'ARSONVAL METER MOVEMENT

PRINCIPLE:-

Whenever electrons flow through a conductor, a magnetic field proportional to the current is created. This effect is useful for measuring current and is employed in many practical meters.

- The basic dc meter movement is known as the D'Arsonval meter movement because it was first employed by the French scientist, D'Arsonval, in making electrical measurement.
- This type of meter movement is a current measuring device which is used in the ammeter, voltmeter, and ohmmeter.
- An ohmmeter is also basically a current measuring instrument, it differs from the ammeter and voltmeter in that it provides its own source of power and contains other auxiliary circuits.

D'ARSONVAL GALVANOMETER:

This instrument is very commonly used in various methods of resistance measurement and also in d.c. potentiometer work.

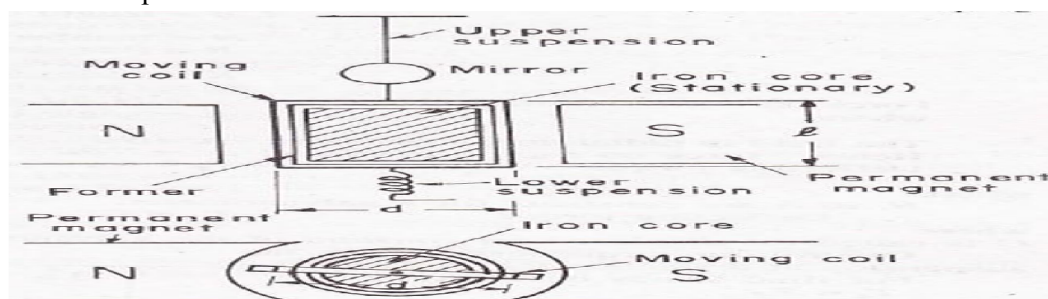

Fig

1) MOVING COIL:

- It is the current carrying element.
- It is either rectangular or circular in shape and consists of number of turns of fine wire.
- This coil is suspended so that it is free to turn about its vertical axis of symmetry.
- It is arranged in a uniform, radial, horizontal magnetic field in the air gap between pole pieces of a permanent magnet and iron core.

- The iron core is spherical in shape if the coil is circular but is cylindrical if the coil is rectangular.
- The iron core is used to provide a flux path of low reluctance and therefore to provide strong magnetic field for the coil to move in.
- This increases the deflecting torque and hence the sensitivity of the galvanometer. The length of air gap is about 1.5mm.
- In some galvanometers the iron core is omitted resulting in of decreased value of flux density and the coil is made narrower to decrease the air gap.
- Such a galvanometer is less sensitive, but its moment of inertia is smaller on account of its reduced radius and consequently a short periodic time.

2) DAMPING:

- There is a damping torque present owing to production of eddy currents in the metal former on which the coil is mounted.
- Damping is also obtained by connecting a low resistance across the galvanometer terminals.
- Damping torque depends upon the resistance and we can obtain critical damping by adjusting the value of resistance.

3) SUSPENSION:

- The coil is supported by a flat ribbon suspension which also carries current to the coil.
- The other current connection in a sensitive galvanometer is a coiled wire. This is called the lower suspension and has a negligible torque effect.
- This type of galvanometer must be leveled carefully so that the coil hangs straight and centrally without rubbing the poles or the soft iron cylinder.
- The upper suspension consists of gold or copper wire of nearly 0.012-5 or 0.02-5 mm diameter rolled into the form of a ribbon.
- This is not very strong mechanically so that the galvanometers must be handled carefully without jerks.

4) INDICATION:

- The suspension carries a small mirror upon which a beam of light is cast. The beam of light is reflected on a scale upon which the deflection is measured. This scale is usually about 1 meter away from the instrument, although $\frac{1}{2}$ meter may be used for greater compactness.

5) ZERO SETTING:

- A torsion head is provided for adjusting the position of the coil and also for zero setting.

2.2.2. PMMC INSTRUMENTS:

- These instruments are used either as ammeters or voltmeters and are suitable for d.c work only.
- PMMC instruments work on the principle that, when a current carrying conductor is placed in a magnetic field, a mechanical force acts on the conductor.
- The current carrying coil, placed in magnetic field is attached to the moving system.
- With the movement of the coil, the pointer moves over the scale to indicate the electrical quantity being measured.
- This type of movement is known as D' Arsonval movement.

CONSTRUCTION:

- It consists of a light rectangular coil of many turns of fine wire wound on an aluminium former inside which is an iron core as shown in fig.
- The coil is delicately pivoted upon jewel bearings and is mounted between the poles of a permanent horse shoe magnet.
- Two soft-iron pole pieces are attached to these poles to concentrate the magnetic field.
- The current is led in to and out of the coils by means of two control hair- springs, one above and other below the coil, as shown in Fig.
- These springs also provide the controlling torque. The damping torque is provided by eddy currents induced in the alluminium former as the coil moves from one position to another.

WORKING:

- When the instrument is connected in the circuit to measure current or voltage, the operating current flows through the coil.
- Since the current carrying coil is placed in the magnetic field of the permanent magnet, a mechanical torque acts on it.
- As a result of this torque, the pointer attached to the moving system moves in clockwise direction over the graduated scale to indicate the value of current or voltage being measured.
- This type of instruments can be used to measure direct current only.
- This is because, since the direction of the field of permanent magnet is same, the deflecting torque also gets reversed, when the current in the coil reverses.
- Consequently, the pointer will try to deflect below zero. Deflection in the reverse direction can be prevented by a “stop” spring.

Permanent magnet, moving coil (PMMC) meter movement

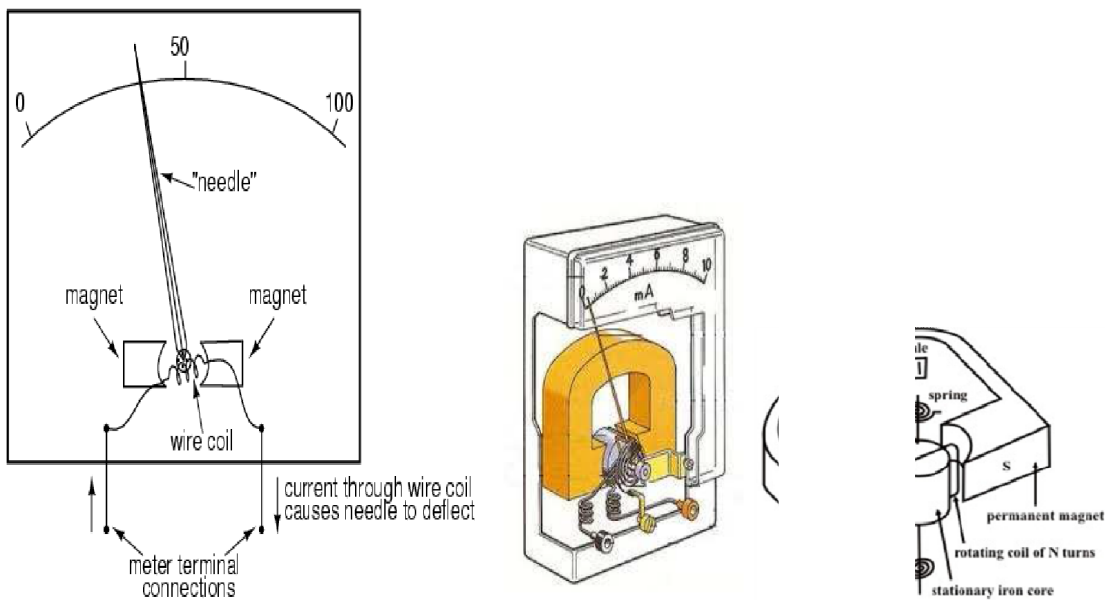

Fig

DEFLECTING TORQUE EQUATION:-

- The magnetic field in the air gap is radial due to the presence of soft iron core. Thus, the conductors of the coil will move at right angles to the field. When the current is passed through the coil, forces act on its both sides which produce the deflecting torque.

Let, B = flux density, Wb/m²
 l = length or depth of coil, m
 b = breadth of the coil.
 N = no. of turns of the coil.

- If a current of 'I' Amperes flows in the coil, then the force acting on each coil side is given by,

Force on each coil side, $F = BIIN$ Newtons.

- Deflecting torque, $T_d = \text{Force} \times \text{perpendicular distance}$
 $= (BIIN) \times b$
 $T_d = BINA$ Newton metre.

Where, $A = l \times b$, the area of the coil in m².

- Thus, $T_d \propto I$
- The instrument is spring controlled so that, $T_c \propto \theta$
- The pointer will come to rest at a position, where $T_d = T_c$
- Therefore, $\theta \propto I$.
- Thus, the deflection is directly proportional to the operating current.
- Hence, such instruments have uniform scale.

ADVANTAGES:

- Uniform scale, i.e., evenly divided scale.
- Very effective eddy current damping.
- High efficiency.
- Require little power for their operation.
- No hysteresis loss (as the magnetic field is constant).
- External stray fields have little effects on the readings (as the operating magnetic field is very strong).
- Very accurate and reliable.

DISADVANTAGES:

- Cannot be used for a.c measurements.
- More expensive (about 50%) than the moving iron instruments because of their accurate design.
- Some errors are caused due to variations (with time or temperature) either in the strength of permanent magnet or in the control spring.

APPLICATIONS:

- In the measurement of direct currents and voltages.
- In d.c galvanometers to detect small currents.
- In Ballistic galvanometers used for measuring changes of magnetic flux linkages.

2.3. OPERATION OF MOVING IRON INSTRUMENT:-

Moving Iron instruments are mainly used for the measurement of alternating currents and voltages, though it can also be used for d.c measurements.

PRINCIPLE OF MOVING IRON INSTRUMENT:-

- Let a plate or vane of soft iron or of high permeability steel forms the moving element of the system.
- The iron vane is situated so as, it can move in a magnetic field produced by a stationary coil.
- The coil is excited by the current or voltage under measurement.
- When the coil is excited, it becomes an electromagnet and the iron vane moves in such a way so as to increase the flux of the electromagnet.
- Thus, the vane tries to occupy a position of minimum reluctance.
- Thus, the force produced is always in such a direction so as to increase the inductance of the coil.

TYPES OF MOVING IRON INSTRUMENTS:

There are two types of Moving- iron instruments

1. ATTRACTION TYPE:

In this type of instrument, a single soft iron vane (moving iron) is mounted on the spindle, and is attracted towards the coil when operating current flows through it.

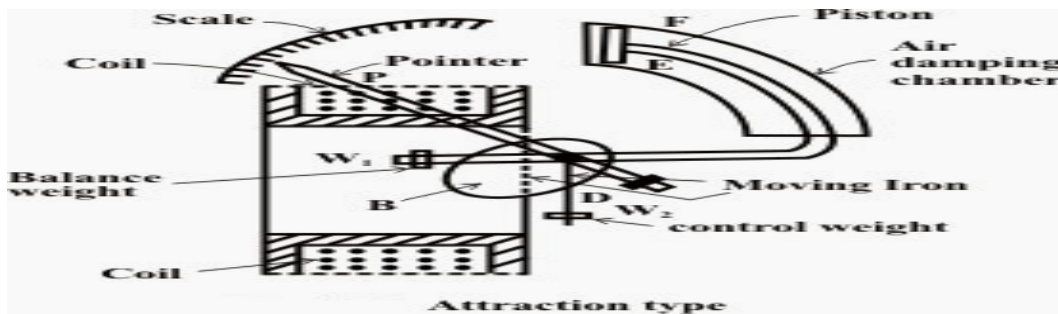

Fig

DEFLECTING TORQUE EQUATION:

- The force F , pulling the soft -iron piece towards the coil is directly proportional to
 - a) Field strength (H) produced by the coil.
 - b) Pole strength (m) developed in the iron piece.
- $F \propto Mh$ Since $m \propto H$,
- Therefore $F \propto H^2$
- Instantaneous deflecting torque $\propto H^2$.
- The field strength $H = \mu i$.
- If the permeability (μ) of the iron is assumed constant, then $H \propto I$.
Where $i \rightarrow$ instantaneous coil current (Ampere).
- Instantaneous deflecting torque $\propto i^2$.
- Average deflecting torque, $T_d \propto$ mean of i^2 over a cycle.
- Since the instrument is spring controlled, hence $T_c \propto \theta$.

- In the steady position of deflection, $T_d = T_c$.
- Therefore $\theta \propto$ mean of i^2 over a cycle $\Rightarrow \theta \propto I^2$ (mean of i^2 over a cycle = I^2).
- Since the deflection is proportional to the square of coil current, the scale of such instruments is non-uniform (being crowded in the beginning and spread out near the finishing end of the scale).

2. REPULSION TYPE:-

- In this two soft iron vanes are used; one fixed and attached the stationary coil, while the other is movable (moving iron), and mounted on the spindle of the instrument.
- When operating current flows through the coil, the two vanes are magnetized, developing similar polarity at the same ends.
- Consequently, repulsion takes place between the vanes and the movable vane causes the pointer to move over the scale.
- It is of two types:-
 - a) Radial vane type: - vanes are radial strips of iron.
 - b) Co-axial vane type:-vanes are sections of coaxial cylinders.

DEFLECTING TORQUE:

- The deflecting torque results due to repulsion between the similarly charged soft- iron pieces or vanes.
- If the two pieces develop pole strength of m_1 and m_2 respectively, then Instantaneous deflecting torque is $\propto m_1 m_2 \propto H^2$.
- If the permeability of iron is assumed constant, then $H \propto i$, where i is the coil current.
- Instantaneous deflecting torque $\propto i^2$.
- Average deflecting torque, $T_d \propto$ mean of i^2 over a cycle.
- Since the instrument is spring controlled, $T_c \propto \theta$.
- In the steady position of deflection, $T_d = T_c$ i.e. $\theta \propto$ mean of i^2 over a cycle $\Rightarrow \theta \propto I^2$ (mean of i^2 over a cycle = I^2).
- Thus, the deflection is proportional to the square of the coil current.
- The scale of the instrument is non- uniform being crowded in the beginning and spread out near the finish end of the scale.
- However, the non- linearity of the scale can be corrected to some extent by the accurate shaping and positioning of the iron vanes in relation to the operating coil.

2.4. PRINCIPLE OF OPERATION OF DC AMMETER AND MULTIRANGE AMMETER

2.4.1. D.C. AMMETER:-

- The PMMC galvanometer constitutes the basic movement of a dc ammeter.
- The coil winding of a basic movement is small and light, so it can carry only very small currents.
- A low value resistor (shunt resistor) is used in DC ammeter to measure large current.
- PMMC movement can be used as DC ammeter by connecting resistor in shunt with it, so that shunt resistance allows a specific fraction of current [excess current greater than full scale deflection current (IFSD)] flowing in the circuit to bypass the meter movement.

- The fractions of the current flowing in the movement indicate the total current flowing in the circuit.
- DC ammeter can be converted into multirange ammeter by connecting number of resistances called multiplier in parallel with the PMMC movement.
- Let R_m = internal resistance of the movement.
- ⇒ I = full scale current of the ammeter + shunt (i.e. total current)
- ⇒ R_{sh} = shunt resistance in ohms.
- ⇒ I_m = full-scale deflection current of instrument in ampere.
- ⇒ $I_{sh} = (I - I_m)$ = shunt current in ampere.
- Since the shunt resistance is in parallel with the meter movement, the voltage drop across the shunt and movement must be the same.
- Therefore, $V_{sh} = V_m$
- ⇒ $I_{sh}R_{sh} = I_mR_m$,
- ⇒ $R_{sh} = (I_mR_m)/I_{sh}$
- But $I_{sh} = I - I_m$
- ⇒ Hence $R_{sh} = (I_mR_m) / (I - I_m)$.
- ⇒ $(I - I_m)/I_m = R_m/R_{sh}$
- ⇒ $(I/I_m) - 1 = R_m/R_{sh}$
- ⇒ $I/I_m = 1 + R_m/R_{sh}$.
- The ratio of the total current to the current in the movement is called Multiplying Power of the Shunt i.e Mathematically, Multiplying Power (m) = $I/I_m = 1 + R_m/R_{sh}$.

2.4.2. MULTIRANGE DC AMMETER:

- The range of the dc ammeter is extended by a number of shunts, selected by a range switch. Such a meter is known as Multirange DC Ammeter.
- The resistors is placed in parallel to give different current ranges.

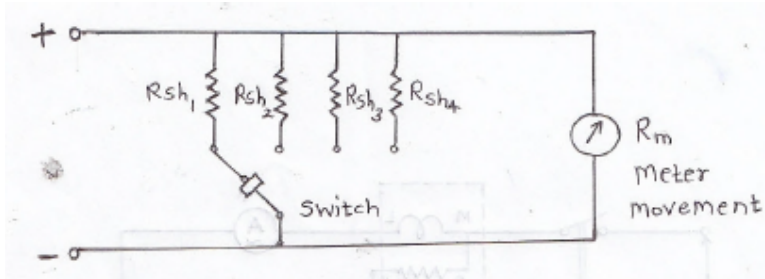

Fig.2.5

- Above figure shows a diagram of multirange ammeter.
- The circuit has 4 shunts R_{sh1} , R_{sh2} , R_{sh3} and R_{sh4} which can be put in parallel with meter movement to give 4 different current ranges I_1 , I_2 , I_3 and I_4 .
- Let m_1 , m_2 , m_3 and m_4 be the shunt multiplying powers for currents I_1 , I_2 , I_3 and I_4 .
- ⇒ $R_{sh1} = R_m/(m_1 - 1)$
- ⇒ $R_{sh2} = R_m/(m_2 - 1)$
- ⇒ $R_{sh3} = R_m/(m_3 - 1)$
- ⇒ $R_{sh4} = R_m/(m_4 - 1)$
- In the Ammeter the multiposition make-before-break switch is used.

- This type of switch is essential in order that meter movement is not damaged when changing from the current range one to another.
- If we provide an ordinary switch the meter remains without a shunt and it is unprotected and therefore it can be damaged when the range is changed.
- Multirange Ammeters are used for the range from the 1 to 50 A.

2.5. AC AMMETER AND MULTIRANGE AMMETERS:

- The PMMC movement cannot be used directly for ac measurements since the inertia of PMMC acts as an averager.
- Because A.C. current has zero average value and it produces a torque that has also zero average value, the pointer just vibrates around zero on the scale.
- In order to make ac measurements, a bridge rectifier circuit is combined with PMMC as shown below.

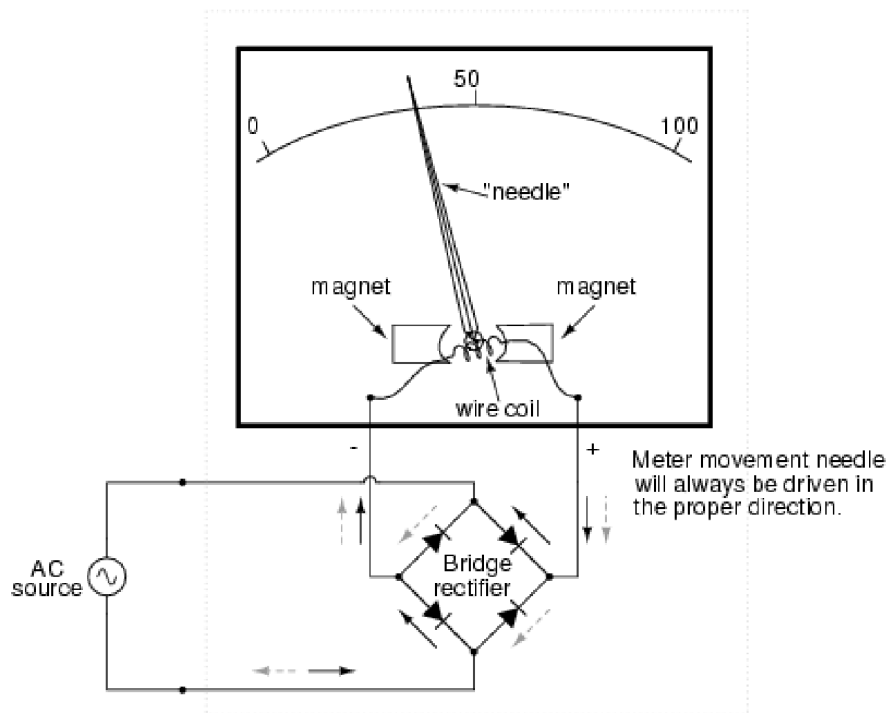

Fig.

2.6. BASIC OPERATION OF OHMMETER:

ELECTRICAL RESISTANCE:

- Electrical resistance is a measure of how much an object opposes allowing an electrical current to pass through it.

OHMMETER:

- It is an electronic device used to measure electrical resistance of a circuit element of low degree of accuracy.
- This resistance reading is indicated through a meter movement.

- The ohmmeter must then have an internal source of voltage to create the necessary current to operate the movement, and also have appropriate ranging resistors to allow desired current to flow through the movement at any given resistance.
- An ohmmeter is useful for
 1. Determining the approximate resistance of circuit components such as heater elements or machine field coils.
 2. Measuring and sorting of resistors used in electronic circuits.
 3. Checking of semiconductor diodes and for checking of continuity of circuit.
 4. To help the precision bridge to calculate the approximate value of resistance which can save time in balancing the bridge.
- There are two types of schemes are used to design an ohmmeter –
 - a) series type
 - b) shunt type.
- The series type of ohmmeter is used for measuring relatively high values of resistance, while the shunt type is used for measuring low values of the resistance.

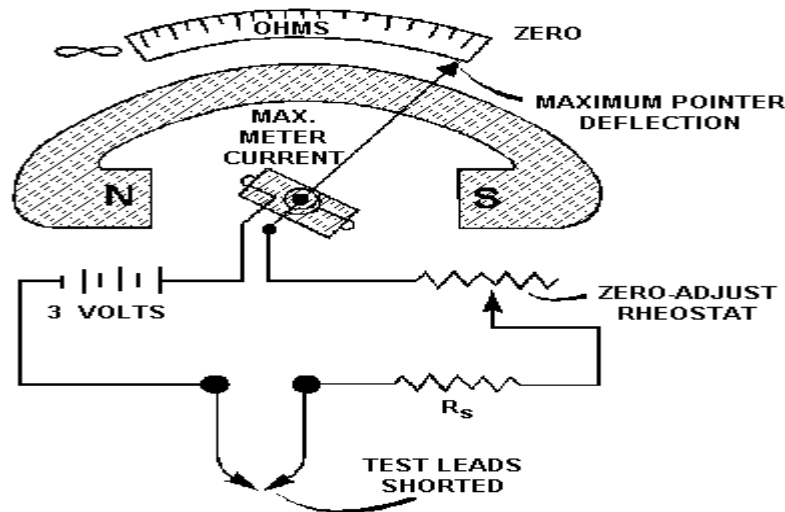
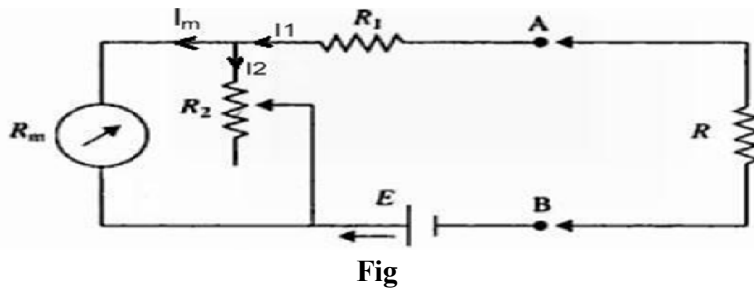

Fig.

- Ohmmeters come with different levels of sensitivity.
- Some Ohmmeters are designed to measure low-resistance materials, and some are used for measuring high-resistance materials.
- A Micro Ohmmeter is used to measure extremely low resistances with high accuracy at particular test currents and is used for bonding contact applications.
- Mega Ohmmeter is used to measure large resistance values.
- Milli-Ohmmeter is used to measure low resistance at high accuracy confirming the value of any electrical circuit.

SERIES TYPE OHMMETER:

- It consists of basic d'Arsonval movement connected in parallel with a shunting resistor R_2 .
- This parallel circuit is in series with resistance R_1 and a battery of emf E .
- The series circuit is connected to the terminals A and B of unknown resistor R_x .



Fig

- From the figure,
 - R_1 = current limiting resistor; R_2 = zero adjusting resistor; E = emf of internal battery; R_m = internal resistance of d'Arsonval movement.
- When the unknown resistance $R_x = 0$ (terminals A and B shorted) maximum current flows through the meter. Under this condition resistor R_2 is adjusted until the basic movement meter indicates full scale current I_{fs} .
- The full scale current position of the pointer is marked " 0Ω " on the scale.
- Similarly when R_x is removed from circuit $R_x = \infty$ (i.e. when terminal A and B are open), the current in the meter drops to the zero and the movement indicates zero current which is the marked " ∞ ".
- Thus the meter will read infinite resistance at the zero current position and zero resistance at full scale current position.
- Since zero resistance is indicated when current in the meter is the maximum and hence the pointer goes to the top mark.
- When the unknown resistance is inserted at terminal A, B the current through the meter is reduced and hence pointer drops lower on the scale.
- Therefore the meter has " 0 " at extreme right and " ∞ " at the extreme left.
- Intermediate scale marking may be placed on the scale by different known values of the resistance R_x to the instrument.
- A convenient quantity to use in the design of the series ohmmeter is the value of the R_x which causes the half scale deflection of the meter.
- At this position, the resistance across terminals A and B is defined as the half scale position resistance R_h .
- The design can be approached by recognizing the fact that when R_h is connected across A and B the meter current reduces to one half of its full scale value or with $R_x = R_h$, $I_m = 0.5 I_{fs}$, where I_m = current through the meter, I_{fs} = current through the meter for full scale deflection.
- This clearly means that R_h is equal to the internal resistance of the ohmmeter looking into terminals A and B.

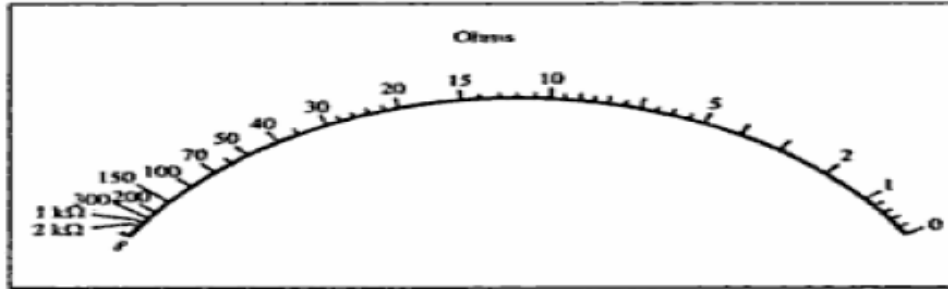

Fig

SHUNT TYPE OHMMETER:-

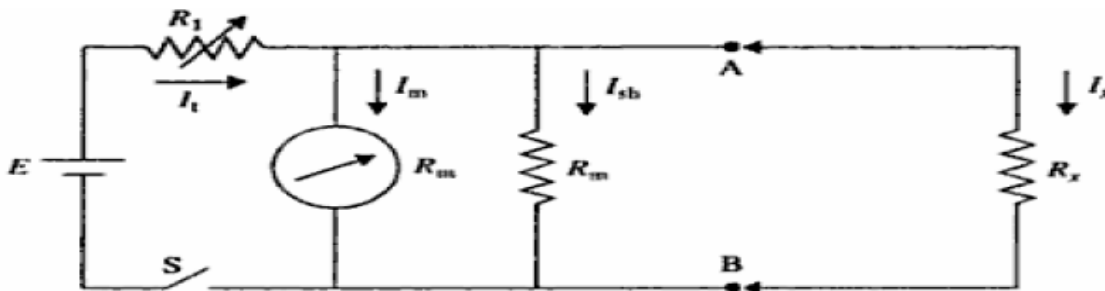

Fig

- This circuit consists of a battery in series with an adjustable resistor R_1 and a basic D'Arsonval movement (meter).
- The unknown resistance is connected across terminals A and B, parallel with the meter.
- In this circuit it is necessary to have an ON-OFF switch to disconnect the battery from the circuit when the instrument is not in use.
- When the unknown Resistor $R_x = 0\Omega$, (i.e. A and B are shorted), the meter current is zero.
- If the unknown Resistor $R_x = \infty\Omega$, (i.e. A and B are open), the meter current flows only through the meter and by selecting a proper value of the resistance R_1 , the pointer may be made to read full scale.
- This ohmmeter therefore, has zero marking on the left hand side of the scale (no current) and ∞ mark on the right hand side of the scale.

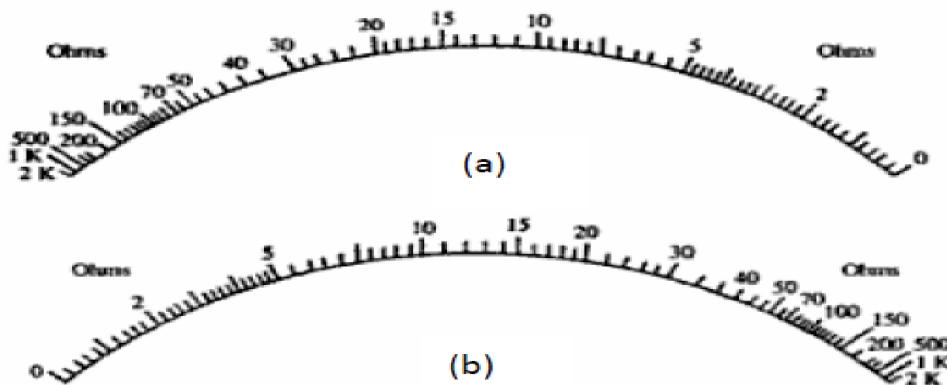

Fig

2.7. ANALOG MULTIMETER:-

- The main part of an analog multi meter is the D'Arsonval meter movement also known as the permanent-magnet moving-coil (PMMC) movement.
- This common type of movement is used for dc measurements.

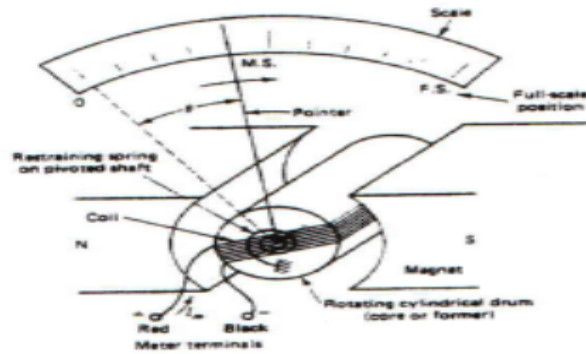

Fig

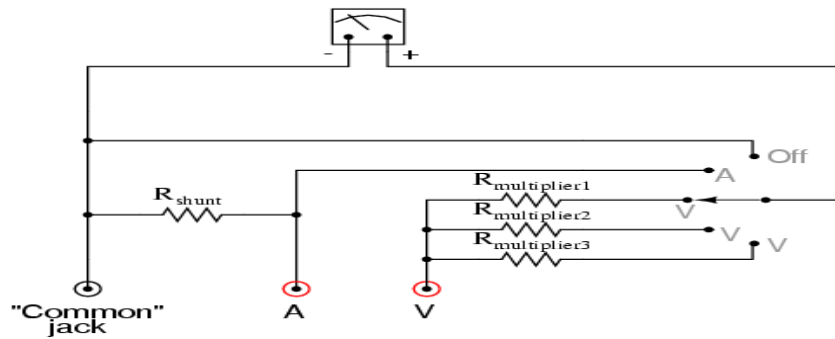

Fig

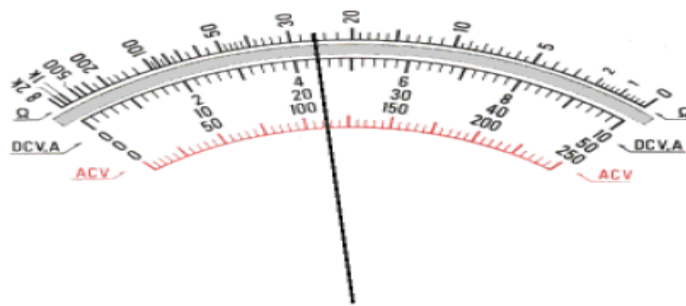

Fig

- When the meter current I_m flows in the wire coil in the direction indicated in figure a magnetic field is produced in the coil.
- This electrically induced magnetic field interacts with the magnetic field of the horseshoe-type permanent magnet.

- The result of such an interaction is a force causing a mechanical torque to be exerted on the coil.
- Since the coil is wound and permanently fixed on a rotating cylindrical drum as shown, the torque produced will cause the rotation of the drum around its pivoted shaft.
- When the drum rotates, two restraining springs, one mounted in the front onto the shaft and the other mounted onto the back part of the shaft, will exhibit a counter torque opposing the rotation and restraining the motion of the drum.
- This spring-produced counter-torque depends on the angle of deflection of the drum, θ or the pointer. At a certain position (or deflection angle), the two torques are in equilibrium.
- Each meter movement is characterized by two electrical quantities
 - a) R_m : the meter resistance which is due to the wire used to construct the coil
 - b) I_{FS} : the meter current which causes the pointer to deflect all the way up to the full-scale position on the fixed scale.
- This value of the meter current is always referred to as the full scale current of the meter movement.
- The PMMC movement cannot be used directly for ac measurements since the inertia of PMMC acts as an averager.
- Since ac current has zero average value and it produces a torque that has also zero average value, the pointer just vibrates around zero on the scale.
- In order to make ac measurements, a bridge rectifier circuit is combined with PMMC as shown in figure below.

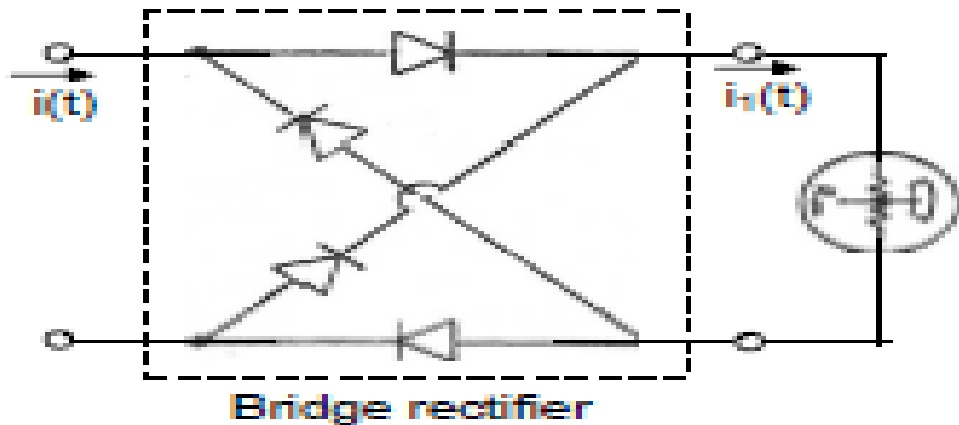

Fig

3rd CHAPTER

DIGITAL INSTRUMENTS

Ramp-type DVM

The principle of operation of the ramp-type DVM is based on the measurements of the time it takes for linear ramp voltage to rise from 0 V to the level of input voltage, or decrease from the level of the input voltage to zero. This interval of time is measured with an electronic time interval counter, and the count is displayed as a number of digits on electronic indicating tubes.

Fig. shows the 'voltage-to-time conversion' using gated clock pulses.

Block Diagram - Ramp type DVM

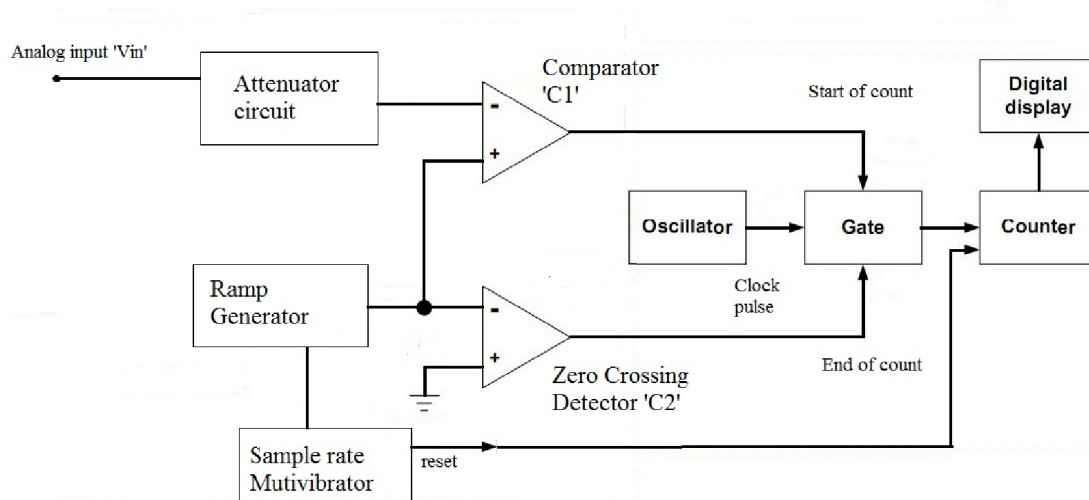

At the start of the measuring cycle, a ramp voltage is initiated; this voltage can be positive going or negative going. The negative going ramp, shown in the fig. is continuously compared with the unknown input-voltage.

At the instant that the ramp voltage equals the unknown voltage, a coincidence circuit, comparator, generates a pulse which opens a gate [see fig.]. The ramp voltage continues to decrease with time until it finally reaches 0 V [or ground potential] and a second comparator generates an output pulse which closes the gate.

An oscillator generates clock pulses which are allowed to pass through the gate to a number of decade counting units [DCUs] which totalise the number of pulses passed through the gate.

The decimal number, displayed by the indicator tubes associated with the DCUs, is a measure of the magnitude of the input voltage.

Waveform Analysis

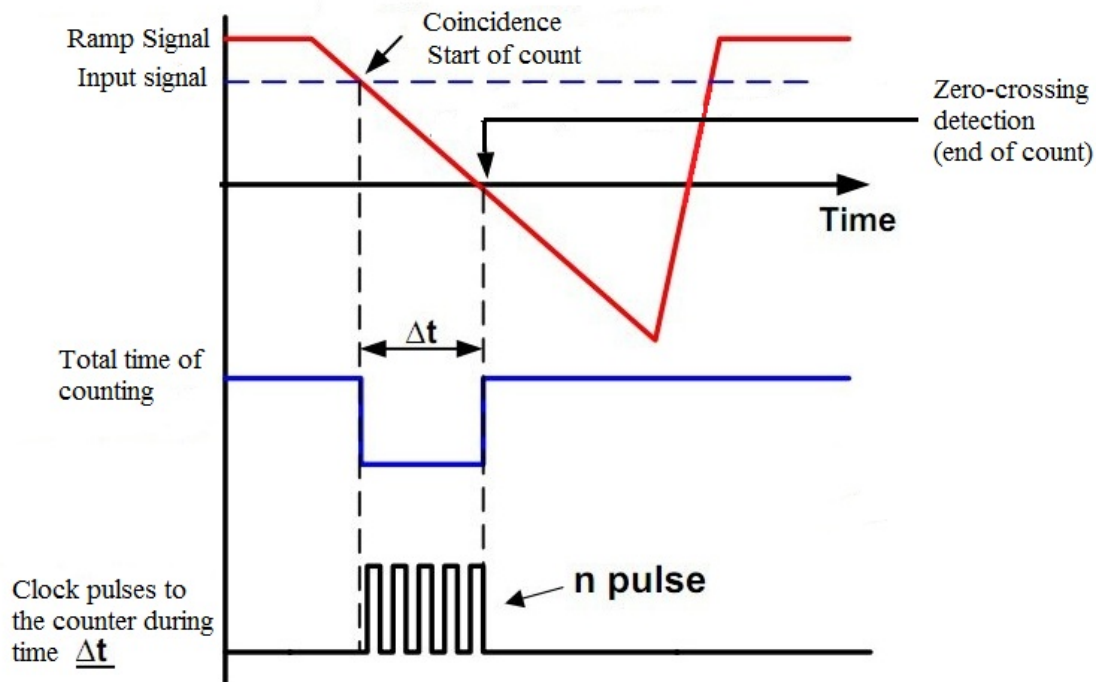

The sample-rate multi-vibrator[MV] determines the rate at which the measurement cycle are initiated. The sample-rate circuit provides an initiating pulse for the ramp generator to start its next ramp voltage. At the same time, a reset pulse is generated which returns all the DCUs to their zero state, removing the display momentarily from the indicator tubes.

Characteristics of Digital Meters

Following are the few specifications which characterise digital meters:

1. **Resolution-** It is defined as the number of digit positions or simply the number of digits used in a meter.

If a number of full digits is n , then resolution,

$$R=1/10^n$$

For $n=4$ $R=1/10^4=0.0001$ or 0.01% .

A three-digit display on the digital meter for 0-1 V range will be able to indicate from 000 to 999mV, with smallest increment (resolution) of 1mV.

2. **Sensitivity-** It is the smallest change in input which a digital meter is able to detect. Thus, it is the full-scale value of the lowest voltage range multiplied by the resolution of the meter. In other words,

$$\text{Sensitivity, } S = (fs)_{\min} * R$$

Where, (fs) =Lowest full-scale value of digital meter, and

R =Resolution is decimal.

DIGITAL FREQUENCY METER

Principle of Operation

Frequency is one of the most basic parameters in electronic, it has very close relationship with many measurement schemes of electric parameter and measurement results, so the frequency measurement becomes more important, it has been widely used in aerospace, electronics, measurement and control field .

Digital frequency meter composed by oscillator, frequency dividers, shaping circuit, counting & decoding IC circuit. Oscillation circuit generates frequency signal, we can get a 0.5HZ signal when the frequency signal through frequency divider.

Diagram of digital frequency meter as shown

in Fig.

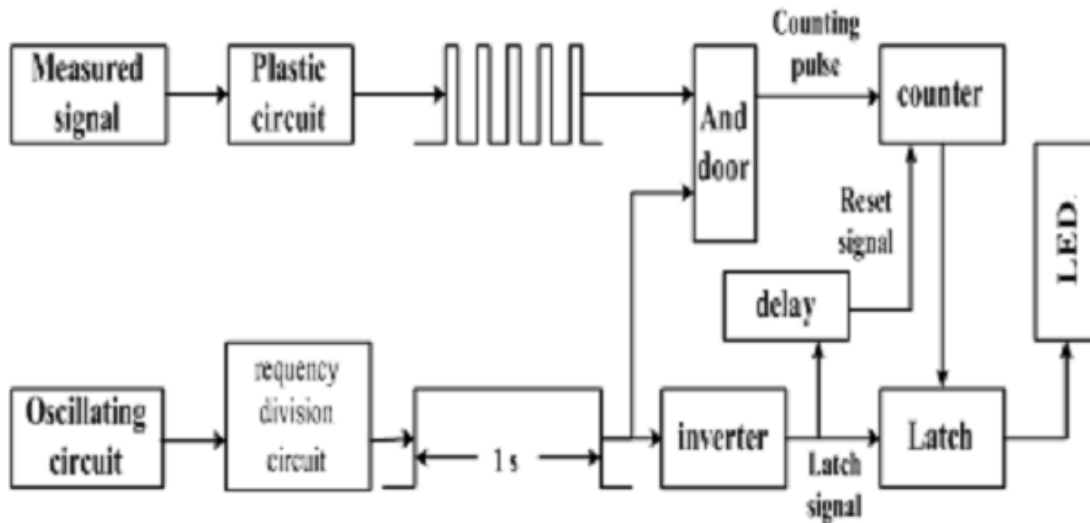

Fig .1 Digital frequency meter principle diagram

Design and simulation of digital frequency meter : Two types are circuits being used in the frequency meter.

Oscillator circuit and frequency division circuit

(1) Oscillator circuit

Oscillator is the core of timer, stability and the accuracy of oscillator frequency determine the timer accuracy[9-10], using IC 555 timing and RC constitute the oscillator which frequency is 500HZ,

(2) Frequency division circuit : Oscillator produce a rectangle wave is 500Hz, using frequency dividers to get 0.5Hz timer signal, 74LS90 is a 2-5 -10 decimal additions counter, use frequency dividers which composed by three 74LS90 can divided 500HZ rectangular pulse into 0.5 HZ.

DIGITAL MULTIMETER

A Digital multimeter offers increased versatility due to its additional capability to measure A.C voltage and current, D.C voltage and current, resistance.

The FIG. Shows the block diagram of a digital multimeter (DMM)

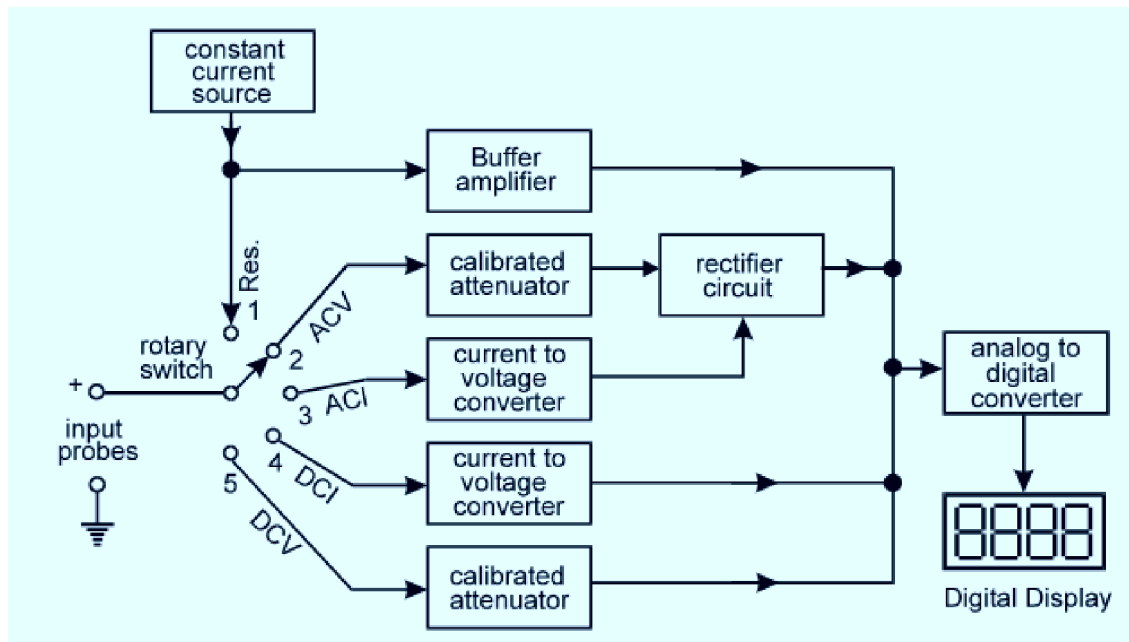

- In the “A.C voltage mode” ,the applied input is fed through a calibrated/ compensated attenuator ,to a precision fu;; wave rectifier circuit followed by a ripple reduction filter
- The resulting D.C fed to ADC and the subsequent display system.
- Fr current measurements the drop across an internal calibrated shunt is measured ,directly By the ADC in the “D.C current mode” , and after A.C to D. C conversion in the “ A.C current mode”. This drop is often in the range of 200 mv.
- Due to lack of precision in the A.C –D.C conversions, the accuracy in the A.C range is in general of the order of 0.2 to 0.5%. In addition , the measurement range is often limited to about 50 Hz at the lower frequency end due to the ripple in the rectified signal becoming a non negligible percentage of the display and hence in fluctuation of the displayed number.
- In the resistance range the multimeter operates by measuring the voltage across the externally connected resistance ,resulting from a current forced through it from a calibrated internal current source.

- The accuracy of resistance measurement is of the order of 0.1 to 0.5% depending on the accuracy and stability of the internal current sources the accuracy may be proper in the highest range which is often about 10 to 20 MΩ. In the lowest range the full scale may be 200Ω with a resolution of about 0.01Ω for a digital multimeter.

Measurement of Time (Period Measurement)

- In some cases it is necessary to measure the time period rather than the frequency. This is especially true in the measurement of frequency in the low frequency range. To obtain good accuracy at low frequency, we should take measurements of the period, rather than make direct frequency measurements. The circuit used for measuring frequency (Fig.) can be used for the measurement of time period if the counted signal and gating signal are interchanged.
- Figure shows the circuit for measurement of time period. The gating signal is derived from the unknown input signal, which now controls the enabling and disabling of the main gate. The number of pulses which occur during one period of the unknown signal are counted and displayed by the decade counting assemblies. The only disadvantage is that for measuring the frequency in the low frequency range, the operator has to calculate the frequency from the time by using the equation $f = 1/T$.

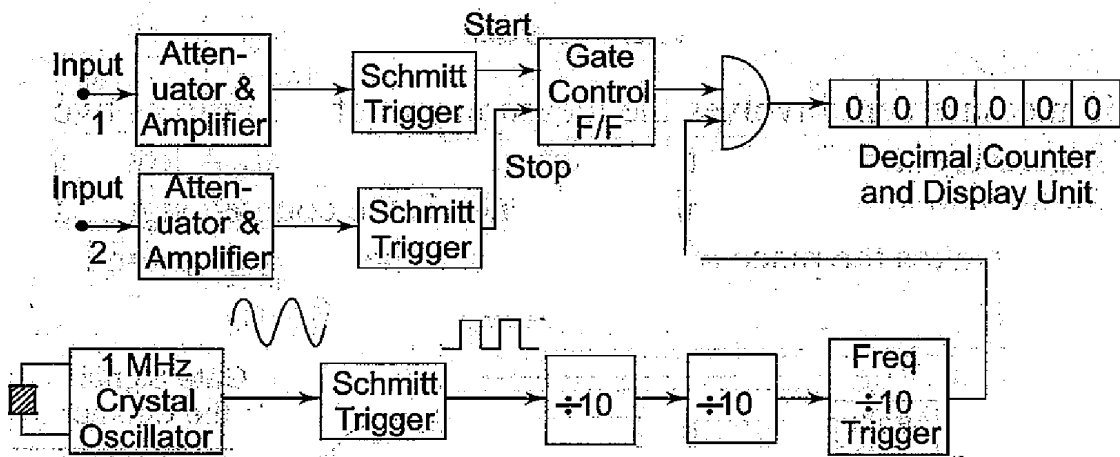

Fig. Basic Block Diagram of Time Measurement

The accuracy of the period measurement and hence of frequency can be greatly increased by using the multiple period average mode of operation. In this mode, the main gate is enabled for more than one period of the unknown signal. This is obtained by passing the unknown signal through one or more decade divider assemblies (DDAs) so that the period is extended by a factor of 10,000 or more.

Hence the digital display shows more digital of information, thus increasing accuracy. However, the decimal point location and measurement units are usually changed each time an additional decade divider is added, so that the display is always in terms of the period of one cycle of the input signal, even though the measurements may have lasted for 10,100 or more cycles.

Figure 6.10 show the multiple average mode of operation. In this circuit, five more decade dividing assemblies are added so that the gate is now enabled for a much longer interval of time than it was with single DDA.

DIGITAL MEASUREMENT OF FREQUENCY (MAINS)

The conventional method of measuring the frequency of an electrical signal consists of counting the number of cycles of the input electrical signal during a specified gate interval. The length of the gate interval decides the resolution of the measurement. The shorter the gate interval, the lesser is the resolution. Now, for frequencies of the order of kHz and above, it is possible to get a resolution of 0.1% of better with a nominal gate time of 1 (sec). But for low frequencies, in order to obtain a resolution of even 0.5%, the gate time has to be considerably larger. For example, consider the case when the input electrical signal frequency is around 50 Hz. In order to obtain a resolution of 0.1 Hz, the gate interval has to be 10 seconds and in order to obtain a resolution of 0.01 Hz, the gate interval has to be 100 s. These gate periods of 10 s and 100 s are too long and in many cases it is desirable to obtain an indication of the frequency in far less time. Hence, direct or ordinary frequency counters are at a great disadvantage when it comes to low frequency measurements.

For the mains frequency monitor, the frequency range of interest is rather narrow, $(50 \pm 5\%)$ Hz. The technique employed in the measurement of mains frequency, yields only a parabolic calibration curve. But within the narrow frequency range, which in this case is $(50 \pm 5\%)$ Hz, the calibration is conveniently flat. Hence, the error due to the non-linear calibration is less than 0.2% at a frequency deviation as large as 5% from the centre frequency, which is 50 Hz. The error is 0.02% at a frequency deviation as large as 2% from the centre frequency and as the frequency approaches the centre value of 50 Hz, the error approaches zero.

DIGITAL TACHOMETER

The technique employed in measuring the speed of a rotating shaft is similar to the technique used in a conventional frequency counter, except that the selection of the gate period is in accordance with the rpm calibration.

Let us assume, that the rpm of a rotating shaft is R . Let P be the number of pulses produced by the pick up for one revolution of the shaft. Therefore, in one minute the number of pulses from the pick up is $R \times P$. Then, the-frequency of the signal from the pick up is $(R \times P)/60$. Now, if the gate period is G s the pulses counted are $(R \times P \times G)/60$. In order to get the direct reading in rpm, the number of pulses to be counted by the counter is R . So we select the gate period as $60/P$, and the counter counts

$$(R \times P \times 60) / 60P = R \text{ pulses}$$

and we can read the rpm of the rotating shaft directly. So, the relation between the gate period and the number of pulses produced by the pickup is $G = 60/P$. If we fix the gate period as one second ($G = 1$ s), then the revolution pickup must be capable of producing 60 pulses per revolution.

Figure shows a schematic diagram of a digital tachometer.

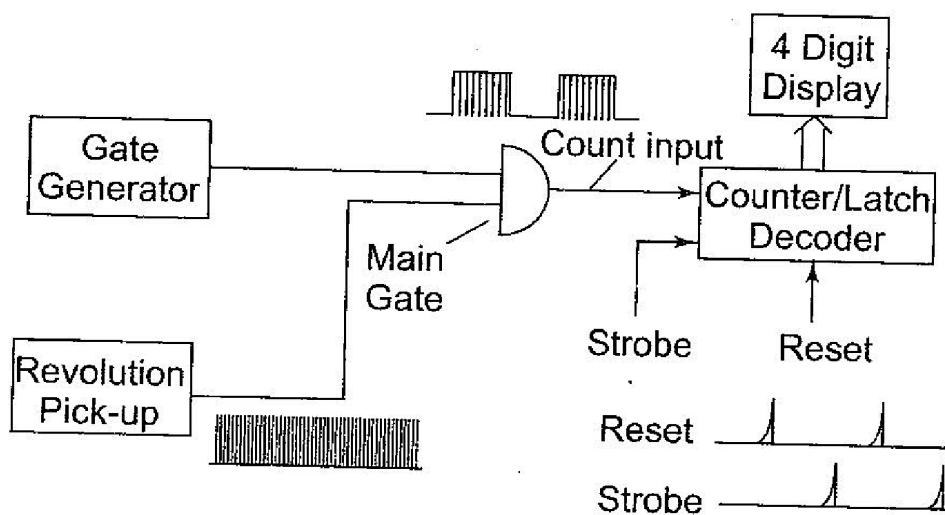

Basic Block Diagram of a Digital Tachometer

AUTOMATION

1. **Automatic Polarity Indication** :The polarity indication is generally obtained from the information in the ADC. For integrating ADCs, only the polarity of the integrated signal is of importance. The polarity should thus be measured at the very end of the integration period (see Fig. 6.21). As the length of the integration period is determined by counting a number of clock pulses, it is logical to use the last count or some of the last counts to start the polarity measurement. The output of the integrator is then used to set the polarity flip-flop, the output of which is stored in memory until the next measurement is made.

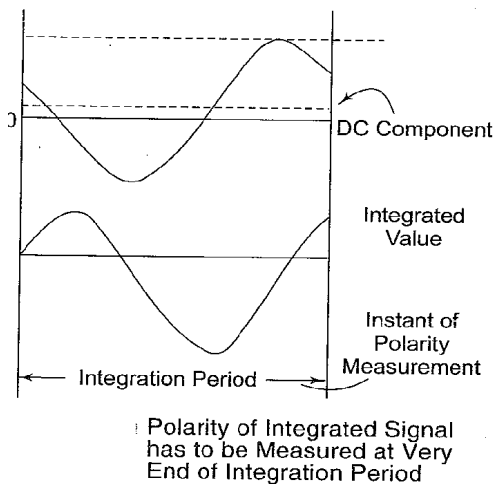

2. **Automatic Ranging**: The object of automatic ranging is to get a reading with optimum resolution under all circumstances (e.g. 170 m V should be displayed as 170.0 and not as 0.170). Let us take the example of a 3Yz digit display, i.e. one with a maximum reading of 1999. This maximum means that any higher value must be reduced by a factor of 10 before it can be displayed (e.g. 201 m V as 0201). On the other hand, any value below 0200 can be displayed with one decade more resolution (e.g. 195 mV as 195.0). In other words, if the display does not reach a value of 0200, the instrument should automatically be switched to a more sensitive range, and if a value of higher than 1999 is offered, the next less sensitive range must be selected.

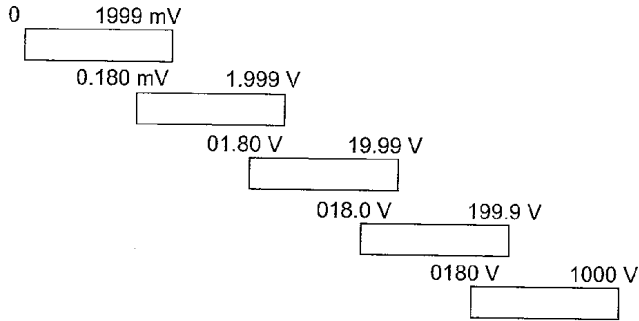

Example of Overlapping Ranges in Automatic Ranging Instruments

3. Automatic Zeroing

Each user of a voltmeter expects the instrument to indicate zero when the input is short-circuited. In a digital voltmeter with a maximum reading of 1999, a zero error of 0.05% of full scale deflection is sufficient to give a reading of 0001. For this reason, and in the interests of optimum accuracy with low valued readings, a zero adjustment is necessary. To increase the ease of operation, many instruments now contain an automatic zeroing circuit.

In a system used in several multimeters, the zero error is measured just before the real measurement and stored as an analog signal. A simplified circuit diagram of a circuit that can be used for this purpose is given in Fig. 6.24, for a dual slope ADC.

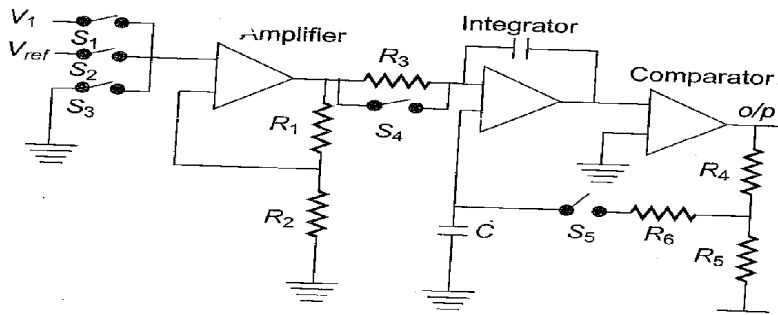

Fig. Simplified Circuit Diagram of Automatic Zeroing Circuit that can be Used With Dual Slope ADC

DIGITAL LCR METER

This type of meter is used to measure the resistance, inductance, capacitance and dissipation factor. The desired function can be selected by using a rotary switch. The various ranges available are

- 1) $200\mu\text{H}/\text{pF}/\Omega$, 2) $2000\mu\text{H}/\text{pF}/\Omega$, 3) $200\text{mH}/\text{nF}/\text{k}\Omega$, 4) $200\text{mH}/\text{nF}/\text{k}\Omega$, 5) $2\text{H}/\mu\text{F}/\text{M}\Omega$

With the help of this instrument, the following ranges of various measurements can be made

Resistance : From $200\ \Omega$ to $20\ \text{M}\ \Omega$;

Inductance : From $2000\ \mu\text{H}$ to $2\ \text{H}$;

Capacitance : From $2000\ \text{pF}$ to $2\ \mu\text{F}$

CHAPTER -4

4.OSCILLOSCOPE

4.1 Discuss the basic principle of Oscilloscope.

A CRO (Cathode-Ray Oscilloscope), or DSO (Digital Storage Oscilloscope), is a type of electronic test instrument that allows observation of constantly varying signal voltages, usually as a two-dimensional plot of one or more signals as a function of time.

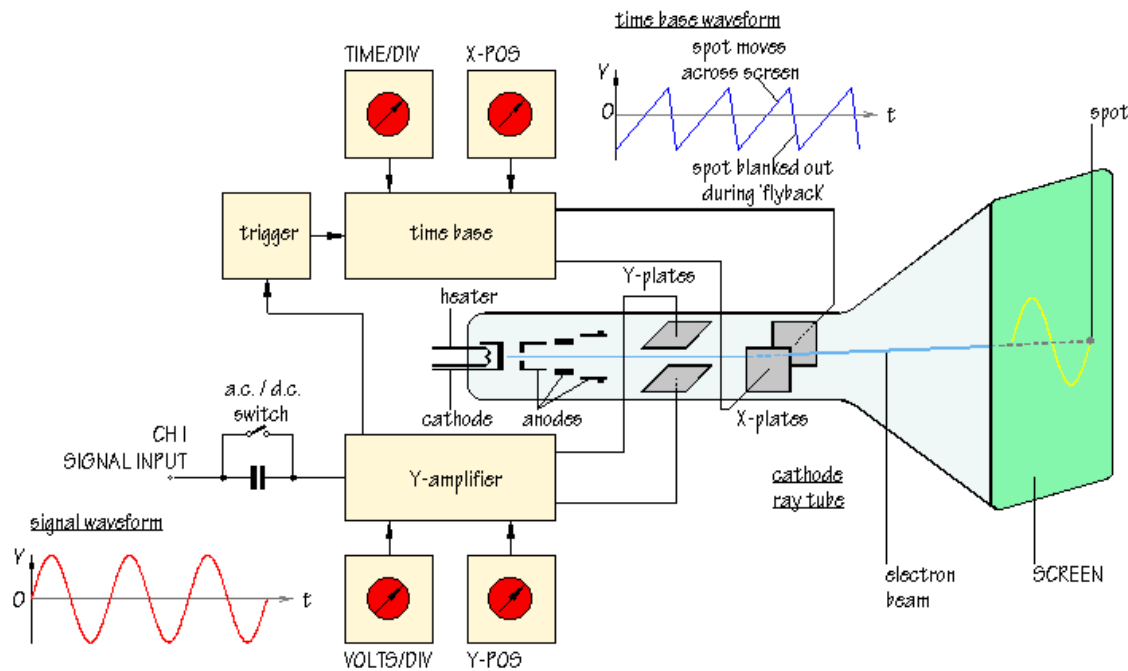

4.2 Discuss the Block Diagram of Oscilloscope & Simple CRO.

The block diagram of simple CRO is as shown in figure below. Here the Oscilloscopes are used to observe the change of an electrical signal over time, such that voltage and time describe a shape which is continuously graphed against a calibrated scale. The observed waveform can be analyzed for such properties as amplitude, frequency, rise time, time interval, distortion and others. Modern digital instruments may calculate and display these properties directly. Originally, calculation of these values required manually measuring the waveform against the scales built into the screen of the instrument.

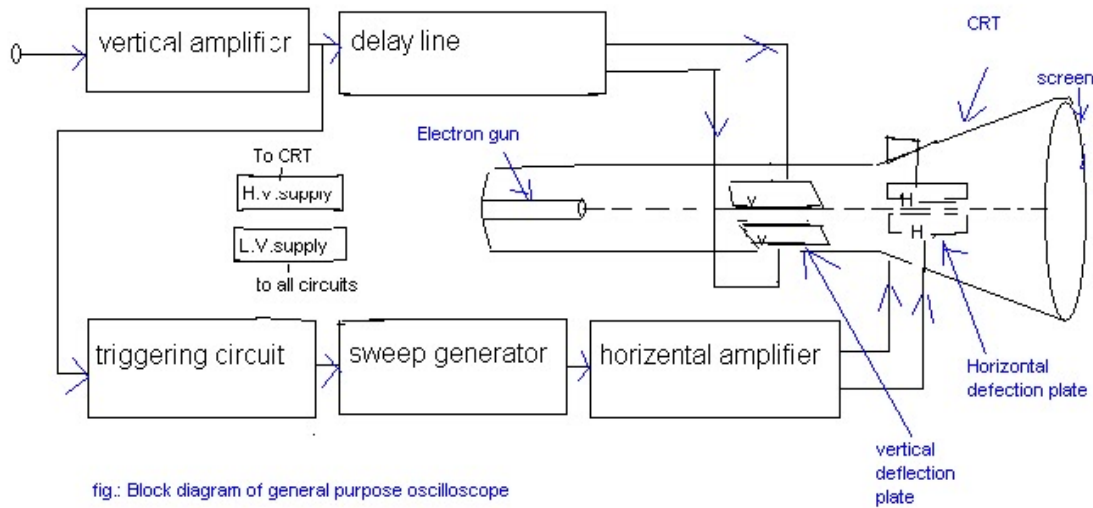

fig.: Block diagram of general purpose oscilloscope

www.ei-notes.blogspot.com

The oscilloscope can be adjusted so that repetitive signals can be observed as a continuous shape on the screen. A storage oscilloscope allows single events to be captured by the instrument and displayed for a relatively long time, allowing human observation of events too fast to be directly perceptible.

Oscilloscopes are used in the sciences, medicine, engineering, and telecommunications industry. General-purpose instruments are used for maintenance of electronic equipment and laboratory work. Special-purpose oscilloscopes may be used for such purposes as analyzing an automotive ignition system or to display the waveform of the heartbeat as an [electrocardiogram](#).



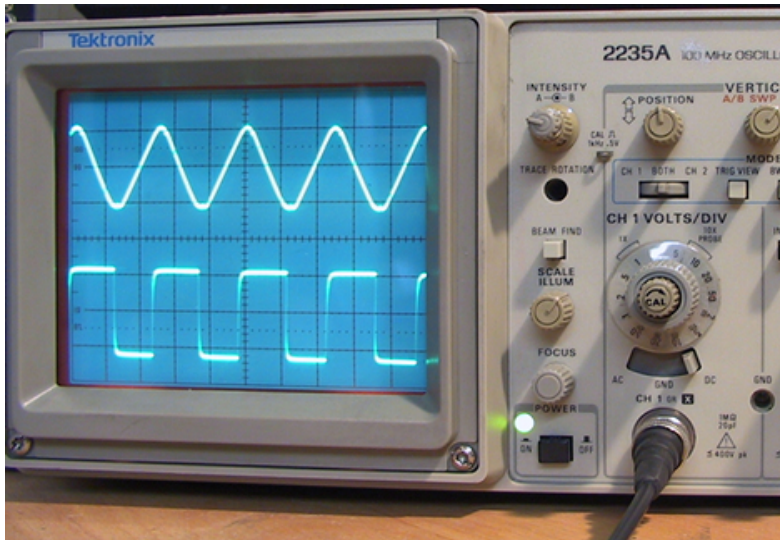

4.3 Discuss the block diagram of Dual Trace Oscilloscope:

Dual Trace CRO:

The block diagram of dual trace oscilloscope which consist of following steps,

1. Electronics gun (single)
2. Separate vertical input channels (Two)
3. Attenuators
4. pr-amplifiers
5. Electronic switch.

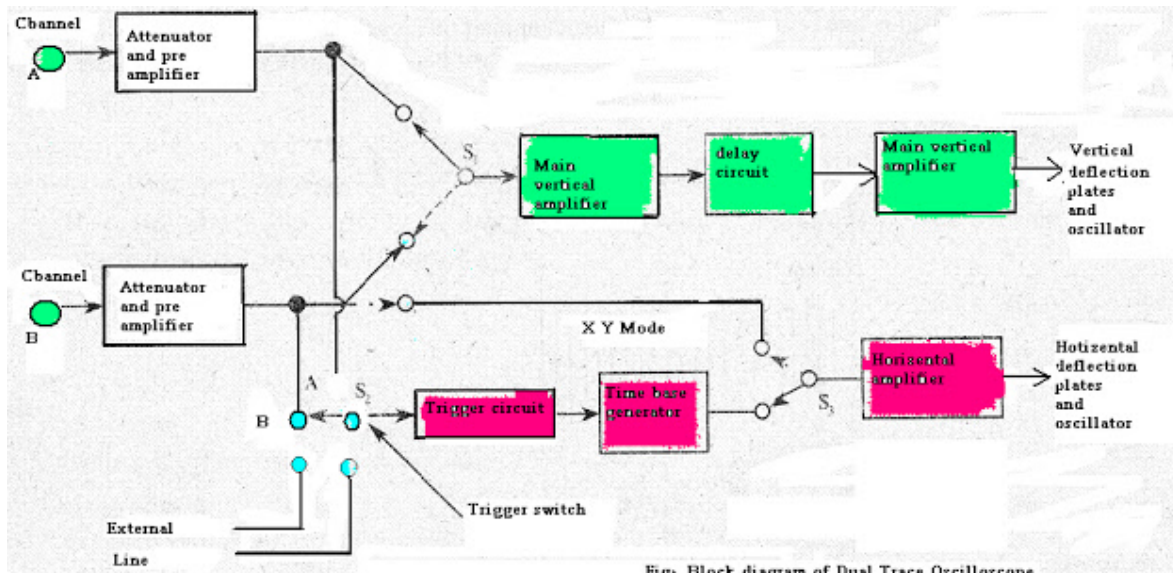

Fig: Block diagram of Dual Trace Oscilloscope

The two separate input signals can be applied to single electron gun with the help of electronic switching it Produces a dual trace display .Each separate vertical input channel are uses separate attenuators and pr-amplifier stages, so the amplitude of each signal can be independently controlled. Output of the pr-amplifiers is given to the electronic switch, which passes one signal at a time into the main vertical amplifier of the oscilloscope.

The time base-generator is similar to that of single input oscilloscope.

By using switch S2 the circuit can be triggered on either A or B channel, waveforms, or an external signal, or on line frequency. The horizontal amplifier can be fed from sweep generator or from channel B by switching S1. When switch S, is in channel B, its oscilloscope operates in the X-Y mode in which channel A acts as the vertical input signal and channel B as the horizontal input signal.

From the front panel several operating modes can be selected for display, like channel B only,

channel A only, channels B and A as two traces, and signals A + B, A - B, B ~ A or - (A + B) as a single trace. Two types of common operating mode are there for the electronic switch, namely,

1. Alternat mode

2. Chop mode.

4.4 Discuss the Dual Trace CRO Specification:

Specifications: 30MHz Dual Trace CRO

Vertical Sensitivity accuracy 1mV/DIV to 2mV/DIV: $\pm 5\%$

5mV/DIV to 5V/DIV: $\pm 3\%$

Bandwidth 1mV/DIV to 2mV/DIV: DC to 7MHz

5mV/DIV to 5V/DIV: DC to 30MHz

AC coupling > 10Hz (reference: 100kHz, 8DIV, -3dB)

Rise time 1mV/DIV to 2mV/DIV: Approx. 50ns , 5mV/DIV to 5V/DIV: Approx. 11.7ns

Input impedance Approx. 1M ohm // 25pF.

Square wave characteristics $\leq 5\%$ Overshoot at 10mV/DIV

Other ranges: 5% added to the above

Linearity ± 0.1 DIV when moving 2 DIV at center

Vertical mode CH1, CH2, DUAL, ADD

Chop frequency Approx. 250kHz

Input coupling AC, GND, DC

Max input voltage CAT II 300Vpeak (AC: $\leq 1\text{kHz}$)

Max effective readout

Probe1:1 40Vpp (14Vrms Sine wave)

Probe10:1 400Vpp (140Vrms Sine wave)

Common mode rejection ratio $\geq 50:1$ at 50kHz sine wave (CH1 and CH2 vertical scales are equal)

Channel isolation @ 5mV/DIV $>1000:1$ at 50kHz $>30:1$ at 30MHz

CH1 signal output $\geq 20\text{ mV/DIV}$ @ 50 Ω , 50Hz to 5MHz

CH2 INV BAL. $\leq 1\text{ DIV}$ (Reference at centergraticule)

4.5 Explain the use of Lissajous method for Phase & Frequency Measurement.

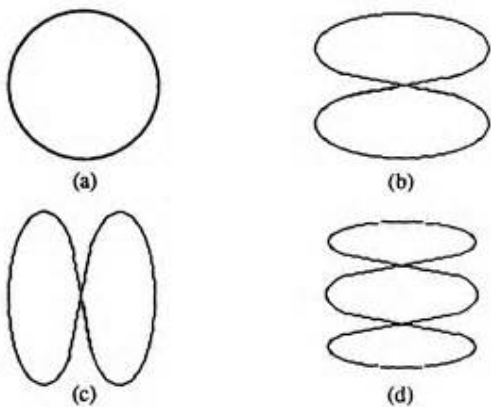
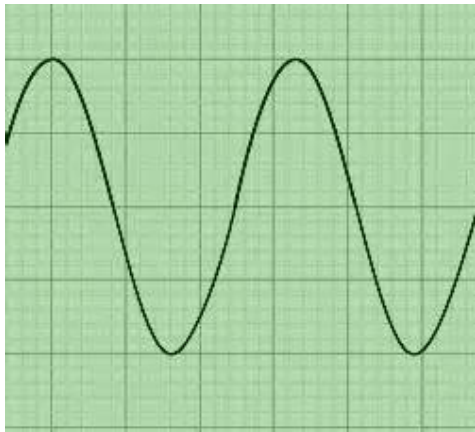
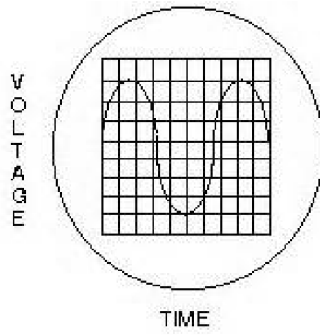
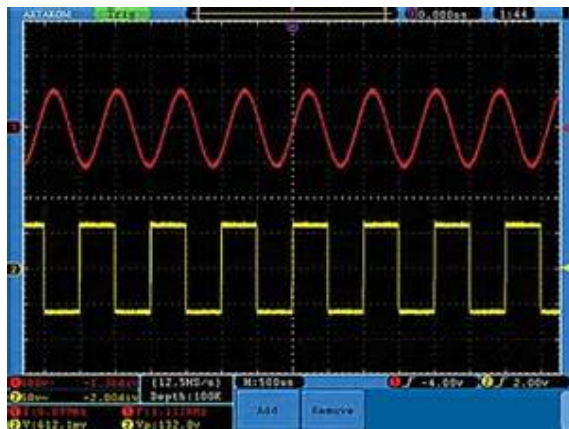
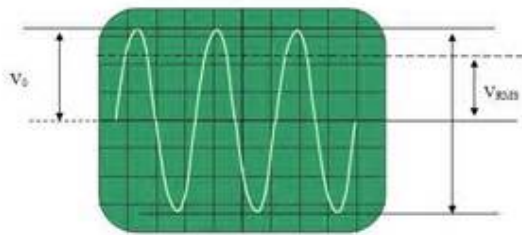

Figure 5. Lissajous figures for horizontal-to-vertical frequency ratios of: (a) 1:1, (b) 2:1, (c) 1:2, and (d) 3:1.



4.6 Application of Oscilloscope.

Time Period Measurement:



Voltage Period Measurement:

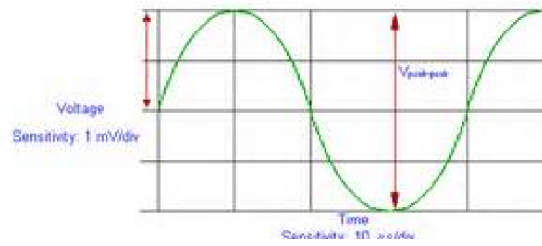
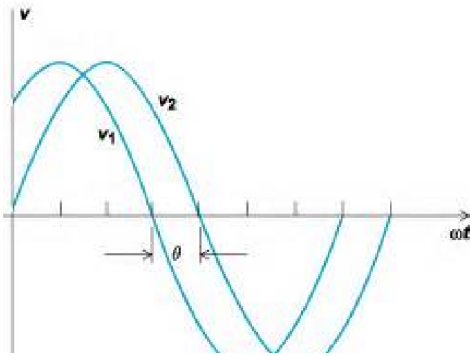

Phase Measurements:

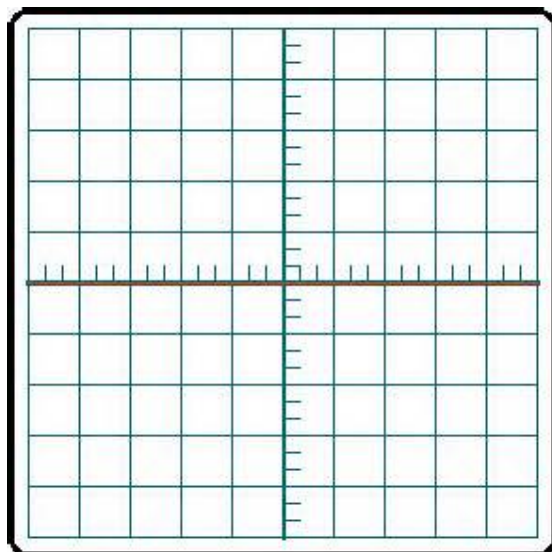
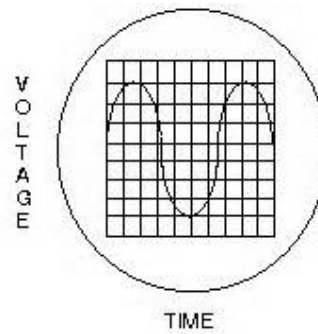
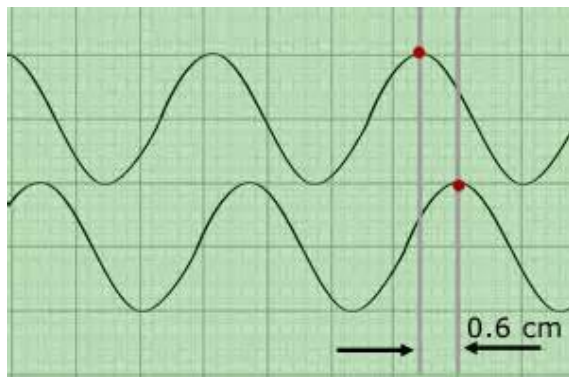

4.7 Explain the operation of Digital Storage Oscilloscope.

Digital Storage Oscilloscope:

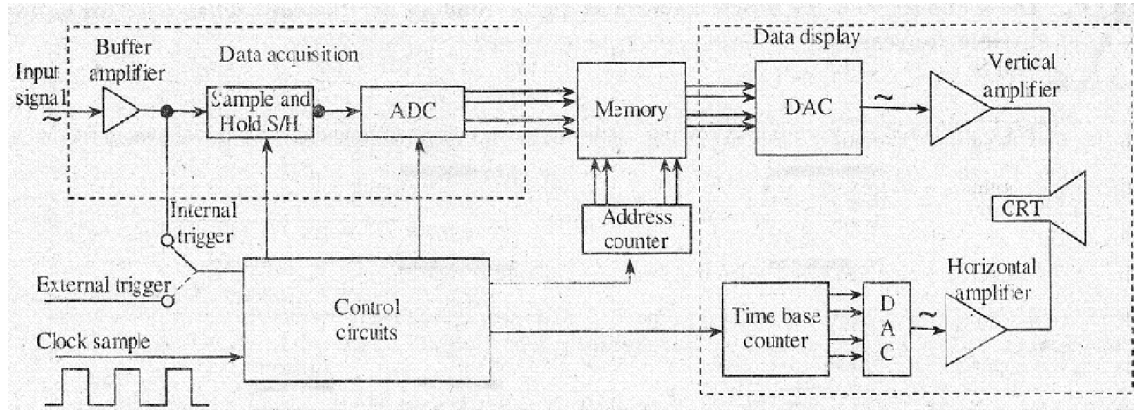
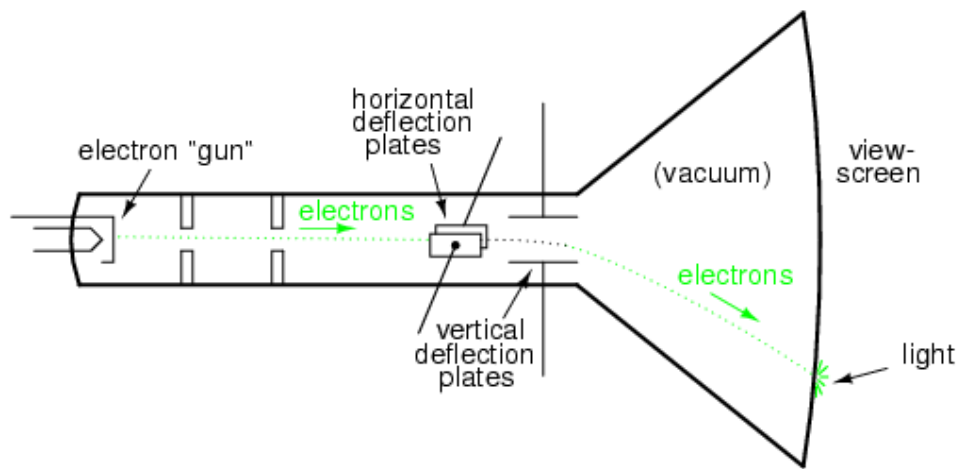

fig 3.1 Block diagram DSO



CHAPTER -5

5. BRIDGES:

5.1 Explain the working of Wheatstone Bridge(Measurement of Resistance)

Wheatstone Bridge

For measuring accurately any electrical resistance **Wheatstone bridge** is widely used. There are two known resistors, one variable resistor and one unknown resistor connected in bridge form as shown below. By adjusting the variable resistor the electric current through the Galvanometer is made zero. When the electric current through the galvanometer becomes zero, the ratio of two known resistors is exactly equal to the ratio of adjusted value of variable resistance and the value of unknown resistance. In this way the value of unknown electrical resistance can easily be measured by using a **Wheatstone Bridge**.

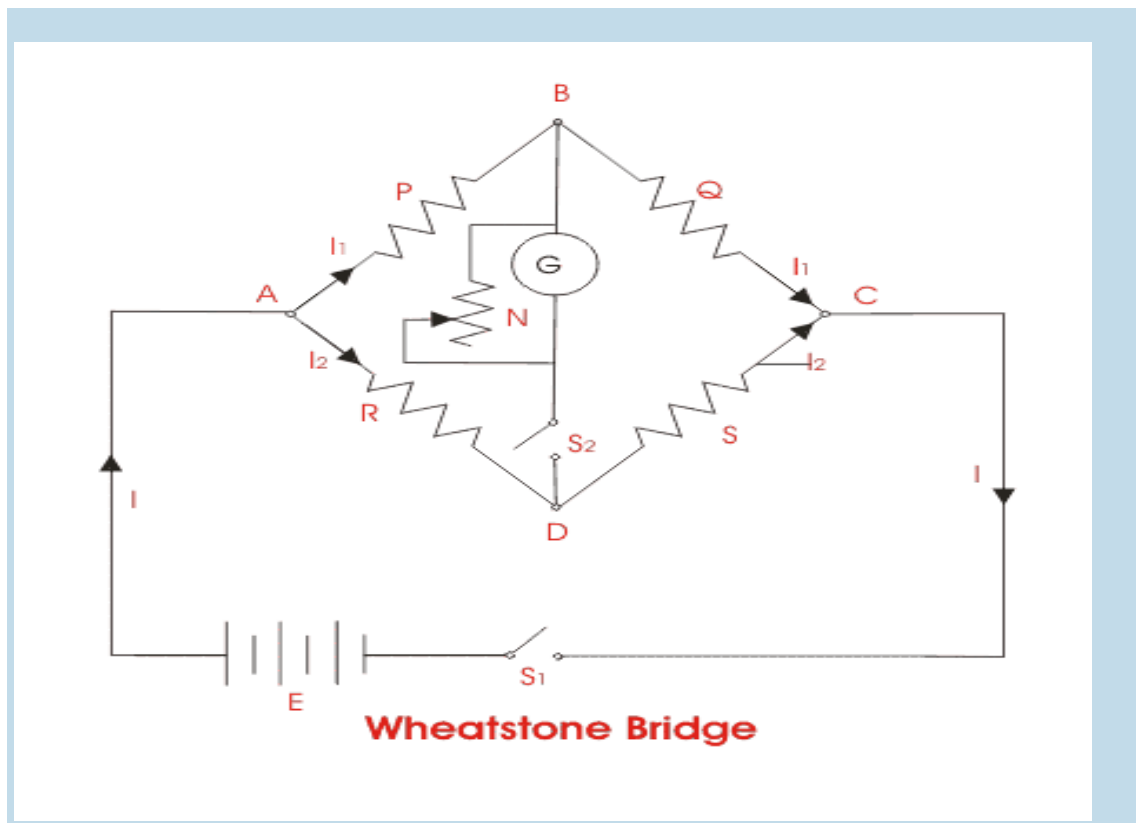

Wheatstone Bridge Theory

The general arrangement of **Wheatstone bridge circuit** is shown in the figure below. It is a four arms bridge circuit where arm AB, BC, CD and AD are consisting of electrical resistances P, Q, S and R respectively. Among these resistances P and Q are known fixed electrical resistances and these two arms are referred as ratio arms. An accurate and sensitive Galvanometer is connected between the terminals B and D through a switch S_2 . The voltage source of this Wheatstone

bridge is connected to the terminals A and C via a switch S_1 as shown. A variable resistor S is connected between point C and D. The potential at point D can be varied by adjusting the value of variable resistor. Suppose electric current I_1 and electric current I_2 are flowing through the paths ABC and ADC respectively. If we vary the electrical resistance value of arm CD the value of electric current I_2 will also be varied as the voltage across A and C is fixed. If we continue to adjust the variable resistance one situation may come when voltage drop across the resistor S that is $I_2 \cdot S$ becomes exactly equal to voltage drop across resistor Q that is $I_1 \cdot Q$. Thus the potential at point B becomes equal to the potential at point D hence potential difference between these two points is zero hence electric current through galvanometer is nil. Then the deflection in the galvanometer is nil when the switch S_2 is closed.

Now, from **Wheatstone bridge circuit**

$$\text{current } I_1 = \frac{V}{P + Q}$$

and

$$\text{current } I_2 = \frac{V}{R + S}$$

Now potential of point B in respect of point C is nothing but the voltage drop across the resistor Q and this is

$$I_1 \cdot Q = \frac{V \cdot Q}{P + Q} \text{-----(i)}$$

Again potential of point D in respect of point C is nothing but the voltage drop across the resistor S and this is

$$I_2 \cdot S = \frac{V \cdot S}{R + S} \text{-----(ii)}$$

Equating, equations (i) and (ii) we get,

$$\begin{aligned} \frac{V \cdot Q}{P + Q} &= \frac{V \cdot S}{R + S} \Rightarrow \frac{Q}{P + Q} = \frac{S}{R + S} \\ \Rightarrow \frac{P + Q}{Q} &= \frac{R + S}{S} \Rightarrow \frac{P}{Q} + 1 = \frac{R}{S} + 1 \Rightarrow \frac{P}{Q} = \frac{R}{S} \\ \Rightarrow R &= S \times \frac{P}{Q} \end{aligned}$$

Here in the above equation, the value of S and P/Q are known, so value of R can easily be determined.

The electrical resistances P and Q of the Wheatstone bridge are made of definite ratio such as 1:1; 10:1 or 100:1 known as ratio arms and S the rheostat arm is made continuously variable from 1 to 1,000 Ω or from 1 to 10,000 Ω

AC Bridges

AC Bridges consist of a source, balance detector and four arms. In AC bridges, all the four arms consists of impedance. The AC bridges are formed by replacing the DC battery with an AC source and galvanometer by detector of Wheatstone bridge. They are highly useful to find out inductance, capacitance, storage factor, dissipation factor etc.

Now let us derive general expression for an AC bridge balance

Figure given below shows AC bridge network:

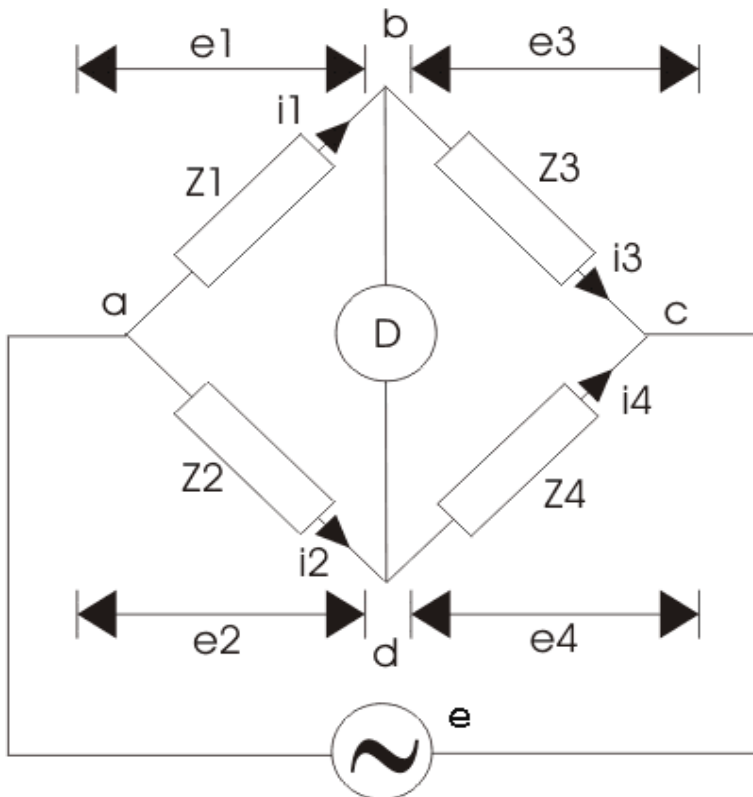

Here Z_1 , Z_2 , Z_3 and Z_4 are the arms of the bridge.

Now at the balance condition, the potential difference between b and d must be zero. From this, when the voltage drop from a to d equals to drop from a to b both in magnitude and phase.

Thus, we have from figure $e_1 = e_2$

$$i_1 \cdot Z_1 = i_2 \cdot Z_2 \dots\dots\dots(1)$$

$$i_1 = i_2 = \frac{e}{Z_1 + Z_3} \dots\dots\dots(2)$$

$$i_2 = i_4 = \frac{e}{Z_2 + Z_4} \dots\dots\dots(3)$$

$$i_2 = i_4 = \frac{e}{Z_2 + Z_4} \dots\dots\dots(3)$$

5.2 Explain the measurement of self inductance by Maxwells Bridge:

MAXWELLS BRIDGE:

This bridge is used to find out the self inductor and the quality factor of the circuit. As it is based on the bridge method (i.e. works on the principle of null deflection method), it gives very accurate results. **Maxwell bridge** is an AC bridge so before going in further detail let us know more about the ac bridge.

Let us now discuss **Maxwell's inductor bridge**. The figure shows the circuit diagram of Maxwell's inductor bridge.

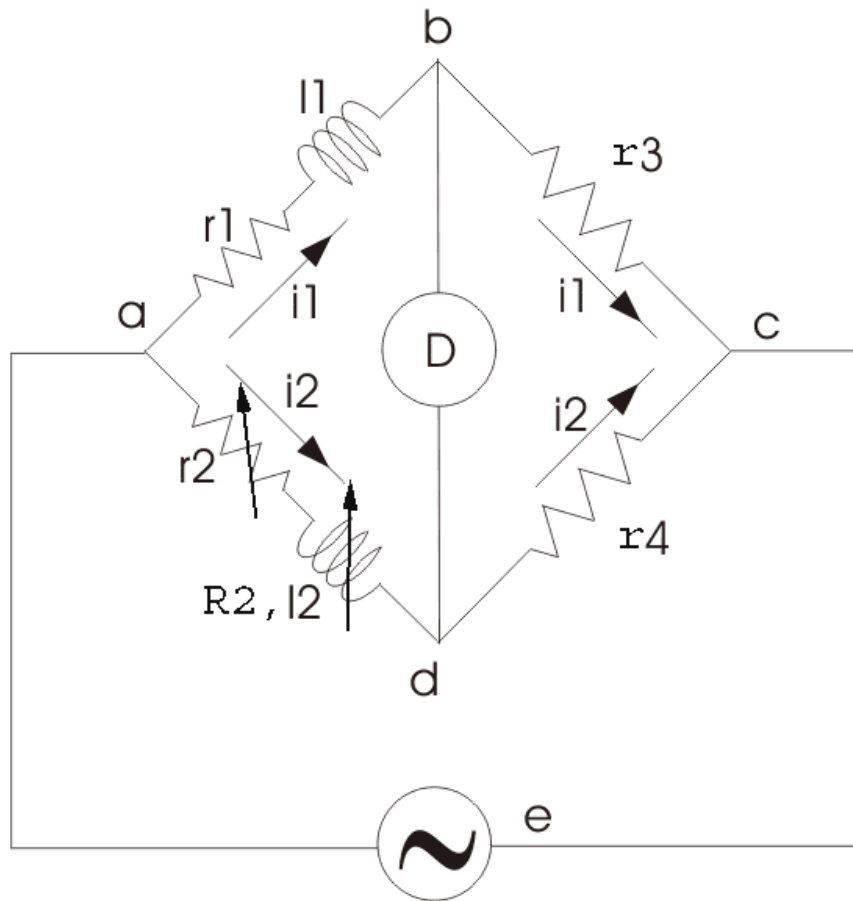

In this bridge the arms bc and cd are purely resistive while the phase balance depends on the arms ab and ad.

Here l_1 =Unknown inductor of r_1 .

l_2 =Variable inductor of resistance R_2 .

r_2 =variable electrical resistance.

As we have discussed in ac bridge according to balance condition, we have at balance point $l_1 = \frac{r_3}{r_4} \cdot l_2$ and $r_1 = \frac{r_3}{r_4}(r_2 + R_2)$

We can vary R_3 and R_4 from 10 ohms to 10,000 ohms with the help of resistance box.

Maxwell's Inductance Capacitance Bridge

In this **Maxwell Bridge**, the unknown inductor is measured by the standard variable capacitor.

Circuit of this bridge is given below,

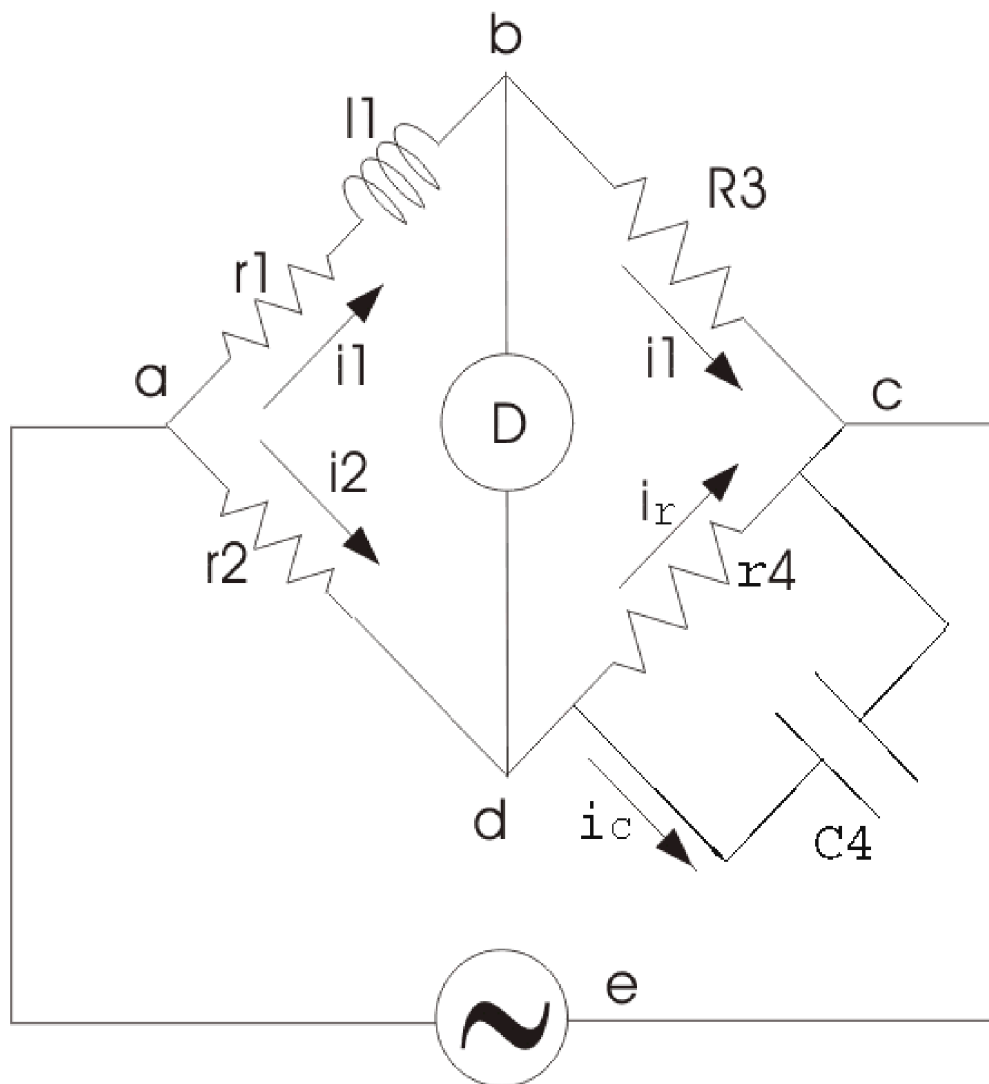

Maxwell's Inductance Capacitance Bridge

Here, l_1 is unknown inductance, C_4 is standard capacitor.

Now under balance conditions we have from ac bridge that $Z_1 Z_4 = Z_2 Z_3$

$$(r_1 + j\omega l_1) \frac{r_4}{1 + j\omega C_4 r_4} = r_2 \cdot r_3$$

$$r_1 \cdot r_4 + j\omega l_1 \cdot r_4 = r_2 \cdot r_3 + j\omega r_2 r_3 C_4 r_4$$

Let us separate the real and imaginary parts, then we have,

$$r_1 = r_2 \cdot \frac{r_3}{r_4} \text{ and } l_1 = r_2 \cdot r_3 \cdot C_4$$

Now the quality factor is given by,

$$Q = \frac{\omega l_1}{r_1} = \omega C_4 \cdot r_4$$

Advantages of Maxwell's Bridge

- (1) The frequency does not appear in the final expression of both equations, hence it is independent of frequency.
- (2) Maxwell's inductor capacitance bridge is very useful for the wide range of measurement of inductor at audio frequencies.

Disadvantages of Maxwell's Bridge

- (1) The variable standard capacitor is very expensive.
- (2) The bridge is limited to measurement of low quality coils ($1 < Q < 10$) and it is also unsuitable for low value of Q (i.e. $Q < 1$) from this we conclude that a Maxwell bridge is used suitable only for medium Q coils.

The above all limitations are overcome by the modified bridge which is known as Hay's bridge which does not use an electrical resistance in parallel with the capacitor.

5.3 Explain the measurement of self inductance by Hay's Bridge:

Hay's Bridge :

A **Hay's bridge** is modified Maxwell bridge, now question arises here in our mind that where we need to do modification. In order to understand this, let us consider the connection diagram given below:

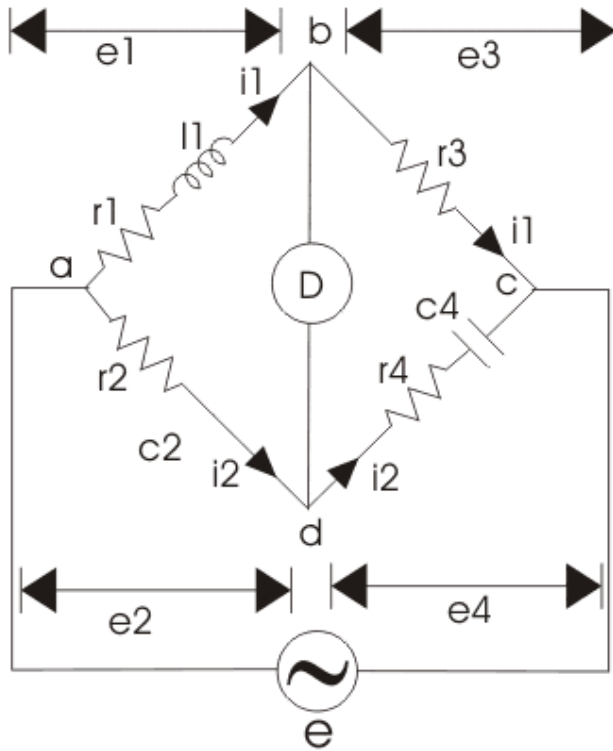

Hay's Bridge Circuit

In this bridge the electrical resistance is connected in series with the standard capacitor. Here l_1 is unknown inductor connected in series with resistance r_1 . c_4 is standard capacitor and r_2, r_3, r_4 are pure electrical resistance forming other arms of the bridge.

From the theory of ac bridge we can write at balance point,

$$z_1 \cdot z_4 = z_3 \cdot z_2 \dots \dots \dots (1)$$

Here, $z_1 = r_1 + j \cdot \omega l_1$

$$z_2 = r_2$$

$$z_3 = r_3$$

$$z_4 = r_4 - \frac{j}{\omega c_4}$$

Substituting the values of z_1, z_2, z_3 and z_4 in equation (1) we get,

$$(r_1 + j\omega l_1) \cdot (r_4 - \frac{j}{\omega c_4}) = r_2 \cdot r_3$$

$$\frac{r_1 \cdot r_4 + l_1}{c_4} = r_2 \cdot r_3 \dots \dots \dots (2)$$

$$\text{and } l_1 = \frac{r_1}{\omega^2 \cdot r_4 \cdot c_4} \dots \dots \dots (3)$$

On solving equation (2) and (3), we have,

$$l_1 = \frac{r_2 \cdot r_3 \cdot c_4}{1 + \omega^2 \cdot c_4^2 \cdot r_4^2} \dots \dots \dots (4)$$

$$r_1 = \frac{\omega^2 \cdot r_2 \cdot r_3 \cdot r_4 \cdot c_4^2}{1 + \omega^2 \cdot c_4^2 \cdot r_4^2} \dots \dots \dots (5)$$

Now, Q factor of a coil is given by

$$Q = \frac{\omega l_1}{r_1} = \frac{1}{\omega \cdot c_4 \cdot r_4}$$

The equations (4) and (5) are dependent on the source frequency hence, in order to find the accurate value of l_1 and r_1 we should know the correct value of source frequency.

Let us rewrite the expression for l_1 ,

$$l_1 = \frac{r_2 \cdot r_3 \cdot c_4}{1 + \omega^2 \cdot c_4^2 \cdot r_4^2} = \frac{r_2 \cdot r_3 \cdot c_4}{1 + \frac{1}{Q^2}}$$

Now if we substitute $Q > 10$ then $1/Q^2 = 1 / 100$ and hence we can neglect this value, thus neglecting $1/Q^2$ we get $r_2 r_3 c_4$ which is same as we have obtained in [Maxwell bridge](#) hence **Hay's bridge circuit** is most suitable for high [inductor](#) measurement.

Hay's Bridge Applications

Before we introduce **Hay's bridge** let us recall the limitations of [Maxwell bridge](#), in order to understand what is the necessity of **Hay's bridge applications**. [Maxwell bridge](#) is only suitable for measuring medium quality factor coils however it is not suitable for measuring high quality factor ($Q > 10$). In order to overcome from this limitation we need to do modification in [Maxwell bridge](#) so that it will become suitable for measuring Q factor over a wide range. This modified [Maxwell bridge](#) is known as **Hay's bridge**.

Advantages of Hay's Bridge

(1) The bridge gives very simple expression for the calculation of unknown [inductor](#) of high value. The Hay's bridge require low value of r_4 while [Maxwell bridge](#) requires high value of r_4 . Now let us analyse why should put low value of r_4 in this bridge:

Consider the expression of quality factor,

$$Q = \frac{1}{\omega C_4 r_4}$$

As r_4 presents in the denominator hence for high quality factor, r_4 must be small.

Disadvantages of Hay's Bridge

Hay's bridge is not suitable for measurement of quality factor ($Q < 10$) for $Q < 10$ we should use [Maxwell bridge](#).

5.4 Explain the measurement of self inductance by Schering Bridge:

Schering Bridge Theory

This bridge is used to measure to the [capacitance](#) of the capacitor, dissipation factor and measurement of relative permittivity. Let us consider the circuit of Schering bridge as shown below:

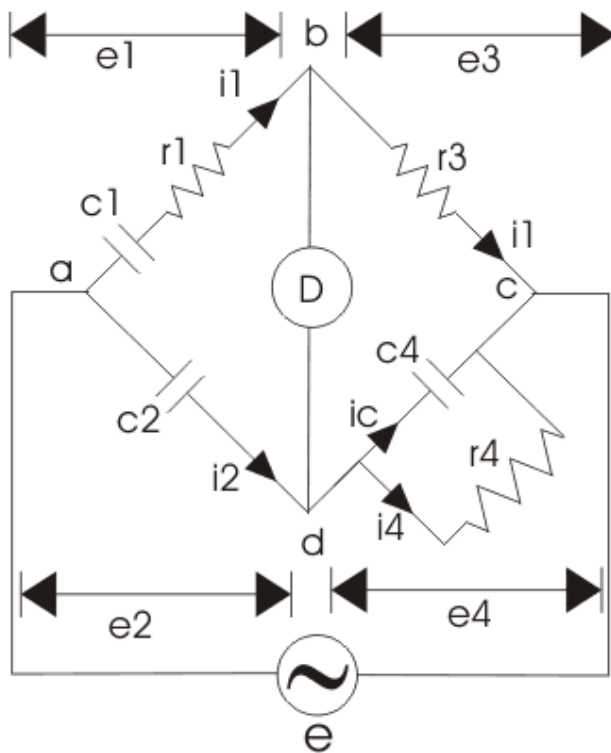

Here, c_1 is the unknown [capacitance](#) whose value is to be determined with series [electrical](#)

resistance r_1 .

c_2 is a standard capacitor.

c_4 is a variable capacitor.

r_3 is a pure resistor (i.e. non inductive in nature).

And r_4 is a variable non inductive resistor connected in parallel with variable capacitor c_4 .

Now the supply is given to the bridge between the points a and c. The detector is connected between b and d. From the theory of ac bridges we have at balance condition,

$$Z_1 Z_4 = Z_2 Z_3$$

Substituting the values of z_1, z_2, z_3 and z_4 in the above equation, we get

$$\left(r_1 + \frac{1}{j\omega c_1} \right) \left(\frac{r_4}{1 + j\omega c_4 r_4} \right) = \frac{r_3}{j\omega c_2}$$

$$\left(r_1 + \frac{1}{j\omega c_1} \right) r_4 = \frac{r_3}{j\omega c_2} (1 + j\omega c_4 r_4)$$

$$r_1 r_4 - \frac{j r_4}{\omega c_1} = - \frac{j r_3}{\omega c_2} + \frac{r_3 r_4 c_4}{c_2}$$

Equating the real and imaginary parts and the separating we get,

$$r_1 = \frac{r_3 c_4}{c_2}$$

$$c_1 = c_2 \frac{r_4}{r_3}$$

Application:

This bridge is used to measure to the capacitance of the capacitor, dissipation factor and measurement of relative permittivity.

5.5 Explain the measurement of Capacitance by Wein,sBridge:

Theory of Owen's Bridge

We have various bridges to measure inductor and thus quality factor, like Hay's bridge is highly suitable for the measurement of quality factor greater than 10, Maxwell's bridge is highly suitable for measuring medium quality factor ranging from 1 to 10 and Anderson bridge can be successfully used to measure inductor ranging from few micro Henry to several Henry. So what is the need of **Owen's bridge**?

The answer to this question is very easy. We need a bridge which can measure inductor over wide range. The bridge circuit which can do that, is known as Owen's bridge. It is ac bridge just like Hay's bridge and Maxwell bridge which use standard capacitor, inductor and variable resistors connected with ac source for excitation. Let us study **Owen's bridge circuit** in more detail.

An Owen's bridge circuit is given below.

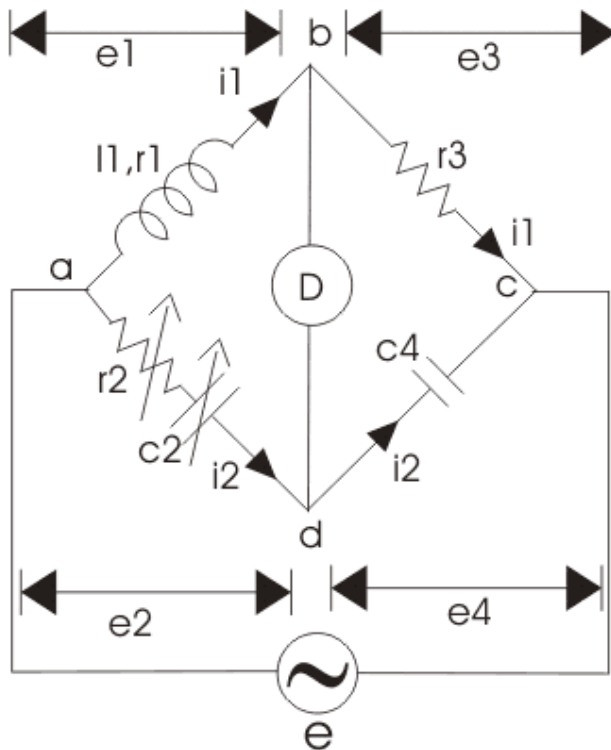

The ac supply is connected at a and c point. The arm ab is having inductor having some finite resistance let us mark them r_1 and l_1 . The arm bc consists of pure electrical resistance marked by r_3 as shown in the figure given below and carrying the electric current i_1 at balance point which is same as the electric current carried by arm ab. The arm cd consists of pure capacitor having no electrical resistance. The arm ad is having variable resistance as well as variable capacitor and the detector is connected between b and d. Now how this bridge works? this bridge measures the inductor in terms of capacitance. Let us derive an expression for inductor for this bridge.

Here l_1 is unknown inductance. And c_2 is variable standard capacitor.

Now at balance point we have the relation from ac bridge theory that must hold good i.e.

$$z_1 z_4 = z_2 z_3$$

Putting the value of z_1 , z_2 , z_3 and in above equation we get,

$$(r_1 + j\omega l_1) \cdot \frac{1}{j\omega c_4} = \left(r_2 + \frac{1}{j\omega c_2}\right) \cdot r_3$$

Equating and then separating the real and the imaginary parts we get the expression for l_1 and r_1 as written below:

$$l_1 = r_2 r_3 c_4 \text{ and } r_1 = \frac{r_3 c_4}{c_2}$$

Advantages of Owen's Bridge

- (1) The for [inductor](#) l_1 that we have derived above is quite simple and is independent of frequency component.
- (2) This bridge is useful for the measurement of [inductor](#) over wide range.

Disadvantages of Owen's Bridge

- (1) In this bridge we have used variable standard [capacitor](#) which is quite expensive item and also the accuracy of this is about only one percent.
- (2) As the measuring quality factor increases the value of standard [capacitor](#) required increases thus expenditure in making this bridge increases.

5.6 Discuss the working principle of Q Meter.

Q METER:

A **Q meter** is a piece of equipment used in the testing of [radio frequency](#) circuits. It has been largely replaced in professional laboratories by other types of [impedance](#) measuring device, though it is still in use among radio amateurs. It was developed at [Boonton Radio Corporation](#) in [Boonton, New Jersey](#) in 1934 by [William D. Loughlin](#).^[1]

A Q meter measures Q, the [quality factor](#) of a circuit, which expresses how much energy is dissipated per cycle in a non-ideal reactive circuit:

$$Q = 2\pi \times \frac{\text{Peak Energy Stored}}{\text{Energy dissipated per cycle}}$$

This expression applies to an [RF and microwave filter](#), bandpass [LC filter](#), or any resonator. It also can be applied to an inductor or capacitor at a chosen frequency. For inductors

$$Q = \frac{X_L}{R} = \frac{\omega L}{R}$$

Where X_L is the reactance of the inductor, L is the inductance, ω is the angular frequency and R is the resistance of the inductor. The resistance R represents the loss in the inductor, mainly due to the resistance of the wire. Q meter works on the principle of series resonance.

For LC band pass circuits and filters:

$$Q = \frac{F}{BW}$$

Where F is the resonant frequency (center frequency) and BW is the filter bandwidth. In a band pass filter using an [LC resonant circuit](#), when the loss (resistance) of the inductor increases, its Q is reduced, and so the bandwidth of the filter is increased. In a coaxial cavity filter, there are no inductors and capacitors, but the cavity has an equivalent LC model with losses (resistance) and the Q factor can be applied as well.

Internally a minimal Q meter consists of a tuneable RF generator, with a very low impedance output, and a detector with a very high impedance input. Additionally there is usually provision to add calibrated amounts of high Q capacitance across the component under test to allow inductors to be measured in isolation. The generator is effectively placed in series with the tuned circuit formed by the components under test, and having negligible output resistance, does not materially affect the Q factor, while the detector measures the voltage developed across one element (usually the capacitor) and being high impedance in shunt does not affect the Q factor significantly either. The ratio of the developed RF voltage to the applied RF current, coupled with knowledge of the

reactive impedance from the resonant frequency, and the source impedance, allows the Q factor to be directly read by scaling the detected voltage.

Q-Meter

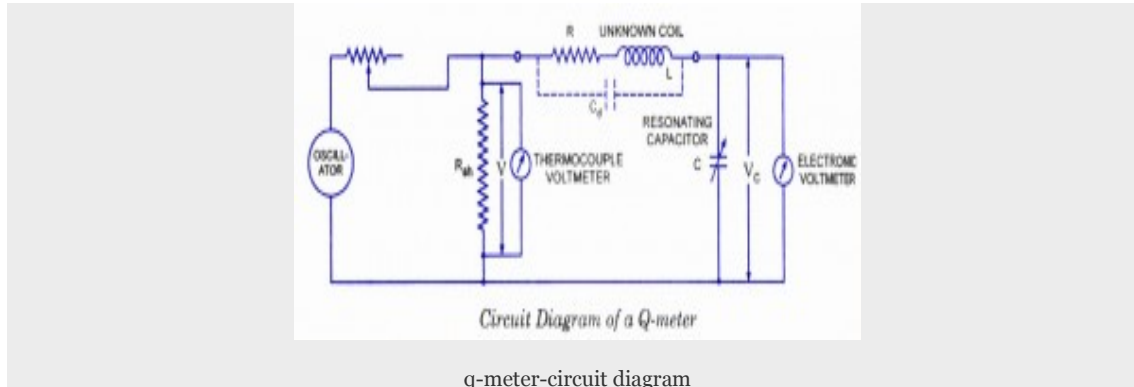

We know that every inductor coil has a certain amount of resistance and the coil should have lowest possible resistance. The ratio of the inductive reactance to the effective resistance of the coil is called the quality factor or Q-factor of the coil.

$$\text{So } Q = X_L / R = \omega L / R$$

A high value of Q is always desirable as it means high inductive reactance and low resistance. A low value of Q indicates that the resistance component is relatively high and so there is a comparatively large loss of power.

The effective resistance of the coil differs from its dc resistance because of eddy current and skin effects and varies in a highly complex manner with the frequency. For this reason Q is rarely computed by determination of R and L.

One possible way for determination of Q is by using the inductance bridge but such bridge circuits are rarely capable of giving accurate measurements, when Q is high. So special meters are used for determination of Q accurately.

The Q-meter is an instrument designed for the measurement of Q-factor of the coil as well as for the measurement of electrical properties of coils and capacitors. -This instrument operates on the principle of series resonance i.e. at resonate condition of an ac series circuit voltage across the capacitor is equal to the applied voltage times of Q of the circuit. If the voltage applied across the circuit is kept-constant then voltmeter connected across the capacitor can be calibrated to indicate Q directly.

Circuit diagram of a Q-meter is shown is figure. A wide-range oscillator with frequency range from 50 kHz to 50 MHz is used as a power supply to the circuit. The output of the oscillator is shorted by a low-value resistance, R_{sh} usually of the order of 0.02 ohm. So it introduces almost no resistance into the oscillatory circuit and represents a voltage source with a very small or of almost negligible internal resistance. The voltage across

the low-value shunt resistance R_{sh} , V is measured by a thermo-couple meter and the voltage across the capacitor, V_c is measured by an electronic voltmeter.

For carrying out the measurement, the unknown coil is connected to the test terminals of the instrument, and the circuit is tuned to resonance either by varying the frequency of the oscillator or by varying the resonating capacitor C . Readings of voltages across capacitor C and shunt resistance R_{sh} are obtained and Q-factor of the coil is determined as follows :

By definition Q-factor of the coil,

$$Q = X_L / R$$

And when the circuit is under resonance condition

$$X_L = X_C$$

$$\text{Or } IX_L = IX_C = V_C$$

And the voltage applied to the circuit.

$$V = IR$$

$$\text{So, } Q = X_L / R = IX_L / R = V_C / V$$

This Q-factor is called the circuit Q because this measurement includes the losses of the resonating capacitor, voltmeter and the shunt resistor R_{sh} . So, the actual Q-factor of the coil will be somewhat greater than the calculated Q-factor. This difference is usually very small and maybe neglected., except when the resistance of the coil under test is relatively small in comparison to the shunt resistance R_{sh} .

The inductance of the coil can also be computed from the known values of frequency f and resonating capacitor C as follows.

At resonance, $X_L = X_C$ or $2\pi fL = 1/2\pi fC$ or $L = 1 / (2\pi f)^2$ Henry.

5.8 Discuss the working principle of LCR Bridge:

LCR METER:

An **LCR meter** is a piece of electronic test equipment used to measure the inductance (L), capacitance (C), and resistance (R) of a component. In the simpler versions of this instrument the true values of these quantities are not measured; rather the impedance is measured internally and converted for display to the corresponding capacitance or inductance value. Readings will be reasonably accurate if the capacitor or inductor device under test does not have a significant resistive component of impedance. More advanced designs measure true inductance or capacitance, and also the equivalent series resistance of capacitors and the Q factor of inductive components.



Usually the [device under test](#) (DUT) is subjected to an [AC voltage source](#). The meter measures the [voltage](#) across and the [current](#) through the DUT. From the ratio of these the meter can determine the magnitude of the impedance. The [phase angle](#) between the voltage and current is also measured in more advanced instruments; in combination with the impedance, the equivalent capacitance or inductance, and resistance, of the DUT can be calculated and displayed. The meter must assume either a parallel or a series model for these two elements. The most useful assumption, and the one usually adopted, is that LR measurements have the elements in series (as would be encountered in an inductor coil) and that CR measurements have the elements in parallel (as would be encountered in measuring a capacitor with a leaky dielectric). An LCR meter can also be used to judge the inductance variation with respect to the rotor position in permanent magnet machines (however care must be taken as some LCR meters can be damaged by the generated EMF produced by turning the rotor of a permanent-magnet motor).

Hand held LCR meters typically have selectable test frequencies of 100 Hz, 120 Hz, 1 kHz, 10 kHz, and 100 kHz for top end meters. The display resolution and measurement range capability will typically change with test frequency.

Benchtop LCR meters typically have selectable test frequencies of more than 100 kHz. They often include possibilities to superimpose a DC voltage or current on the AC measuring

signal. Lower end meters offer the possibility to externally supply these DC voltages or currents while higher end devices can supply them internally. In addition benchtop meters allow the usage of special fixtures to measure SMD components, air-core coils or transformers.

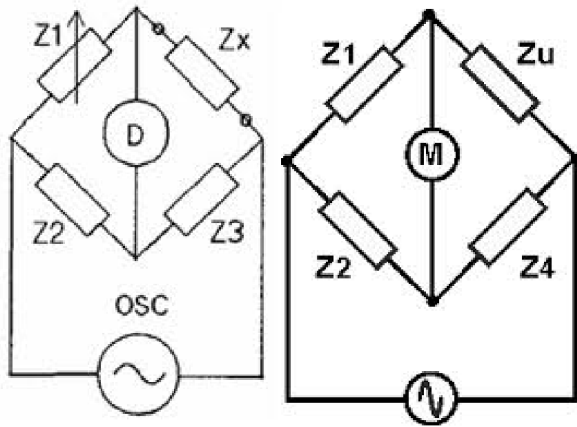

In order to understand the concept of **errors in measurement**, we should know the two terms that define the error and these two terms are written below:

True Value

It is not possible to determine the true value of a quantity by experimental means. True value may be defined as the average value of an infinite number of measured values when average deviation due to various contributing factors will approach to zero.

Measured Value

It may be defined as the approximated value of true value. It can be found out by taking means of several measured readings during an experiment, by applying suitable approximations on physical conditions.

Now we are in a position to define static error. Static error is defined as the difference of the measured value and the true value of the quantity. Mathematically we can write an expression of error as, $dA = A_m - A_t$ where dA is the static error A_m is measured value and A_t is true value.

It may be noted that the absolute value of error cannot be determined as due to the fact that the true value of quantity cannot be determined accurately.

Let us consider few terms related to errors.

Limiting Errors or Guarantee Errors

The concept of guarantee errors can better clear if we study this kind of error by considering one example. Suppose there is a manufacturer who manufacture an ammeter, now he should promises that the error in the ammeter he is selling not greater the limit he sets. This limit of error is known as limiting errors or guarantee error.

Relative Error or Fractional Error

It is defined as the ratio of the error and the specified magnitude of the quantity. Mathematically we write as,

$$\text{Relative Error} = \frac{dA}{A}$$

Where dA is the error and A is the magnitude.

Now here we are interested in computing resultant limiting error under the following cases:

(a) By taking the sum of two quantities: Let us consider two measured quantities a_1 and a_2 . The sum of these two quantities can be represented by A . Thus we can write $A = a_1 + a_2$. Now the relative incremental value of this function can be calculated as

$$\frac{dA}{A} = \frac{d(a_1 + a_2)}{A}$$

Separating the each term as shown below and by multiplying and dividing a_1 with the first term and a_2 with the second term we have

$$\frac{dA}{A} = \frac{a_1 \cdot da_1}{A \cdot a_1} + \frac{a_2 \cdot da_2}{A \cdot a_2}$$

From the above equation we can see that the resultant limiting error is equal to the sum of products formed by multiplying the individual relative limiting errors by the ratio of each term to the function. Same procedure can be applied to calculate the resultant limiting error due to summation of more than two quantities. In order to calculate the resultant limiting error due to difference of the two quantities just change the addition sign with subtraction and rest procedure is same.

(b) By taking the product of two quantities: Let us consider two quantities a_1 and a_2 . In this case the product of the two quantities are expressed as $A = a_1 \cdot a_2$. Now taking log both sides and differentiating with respect to A we have resultant limiting errors as

$$\frac{dA}{A} = \frac{da_1}{a_1} + \frac{da_2}{a_2}$$

From this equation we can see that the resultant error is summation of relative **errors in measurement** of terms. Similarly we can calculate the resultant limiting error for power of factor. Hence the relative error would be n times in this case.

Types of Errors

Basically there are three **types of errors** on the basis; they may arise from the source.

Gross Errors

This category of errors includes all the human mistakes while reading, recording and the readings. Mistakes in calculating the errors also come under this category. For example while taking the reading from the meter of the instrument he may read 21 as 31. All these types of error are come under this category. Gross errors can be avoided by using two suitable measures and they are written below:

- (i) A proper care should be taken in reading, recording the data. Also calculation of error should be done accurately.
- (ii) By increasing the number of experimenters we can reduce the gross errors. If each experimenter takes different reading at different points, then by taking average of more readings we can reduce the gross errors.

Systematic Errors

In order to understand these kinds of errors, let us categorize the systematic errors as

(i) Instrumental Errors

These errors may be due to wrong construction, calibration of the measuring instruments. These types of error may be arises due to friction or may be due to hysteresis. These types of errors also include the loading effect and misuse of the instruments. Misuse of the instruments results in the failure to the adjust the zero of instruments. In order to minimize the gross errors in measurement various correction factors must be applied and in extreme condition instrument must be re-calibrated carefully.

(ii) Environmental Errors

This type of error arises due to conditions external to instrument. External condition includes temperature, pressure, humidity or it may include external magnetic field. Following are the steps that one must follow in order to minimize the environmental errors:

(A)Try to maintain the temperature and humidity of the laboratory constant by making some arrangements.

(B)Ensure that there should not be any external magnetic or electrostatic field around the instrument.

Observational Errors

As the name suggests these **types of errors** are due wrong observations. The wrong observations may be due to PARALLAX. In order to minimize the PARALLAX error highly accurate meters are required, provided with mirrored scales.

Random Errors

After calculating all systematic errors, it is found that there are still some errors in measurement are left. These errors are known as random errors. Some of the reasons of the appearance of these errors are known but still some reasons are unknown. Hence we cannot fully eliminate these kinds of error.

ermanent Magnet Moving Coil Instrument

The **permanent magnet moving coil instrument** or **PMMC type instrument** uses two permanent magnets in order to create stationary magnetic field. These types of instruments are only used for measuring the dc quantities as if we apply ac electric current to these type of

instruments the direction of [electric current](#) will be reversed during negative half cycle and hence the direction of torque will also be reversed which gives average value of torque zero. The pointer will not deflect due to high frequency from its mean position showing zero reading. However it can measure the direct [electric current](#) very accurately.

Let us move towards the constructions of **permanent magnet moving coil instruments**. We will see the construction of these types of instruments in five parts and they are described below:



(a) **Stationary part or magnet system:** In the present time we use magnets of high field intensities, high coercive force instead of using U shaped permanent magnet having soft iron pole pieces. The magnets which we are using nowadays are made up of materials like alcomax and alnico which provide high field strength.

(b) **Moving coil:** The moving coil can freely moves between the two permanent magnets as shown in the figure given below. The coil is wound with many turns of copper wire and is placed on rectangular aluminium which is pivoted on jeweled bearings.

(c) **Control system:** The spring generally acts as control system for PMMC instruments. The spring also serves another important function by providing the path to lead [electric current](#) in and out of the coil.

(d) **Damping system:** The damping force hence torque is provided by movement of aluminium former in the magnetic field created by the permanent magnets.

(e) **Meter:** Meter of these instruments consists of light weight pointer to have free movement and scale which is linear or uniform and varies with angle.

Let us derive a general expression for torque in permanent magnet moving coil instruments or **PMMC instruments**. We know that in moving coil instruments the deflecting torque is given by the expression:

$T_d = NBIdI$ where N is number of turns,

B is magnetic flux density in air gap,

I is the length of moving coil,

d is the width of the moving coil,

And I is the electric current.

Now for a moving coil instruments deflecting torque should be proportional to current, mathematically we can write $T_d = GI$. Thus on comparing we say $G = NBId$. At steady state we have both the controlling and deflecting torques are equal. T_c is controlling torque, on equating controlling torque with deflection torque we have $GI = K.x$ where x is deflection thus electric current is given by $I = \frac{K}{G}x$

Since the deflection is directly proportional to the electric current therefore we need a uniform scale on the meter for measurement of current.

Now we are going to discuss about the basic circuit diagram of the ammeter. Let us consider a circuit as shown below:

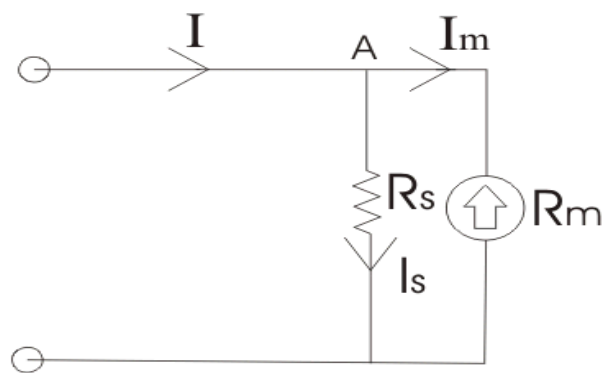

Basic Ammeter Circuit

The electric current I is shown which breaks into two components at the point A. The two components are I_s and I_m . Before I comment on the magnitude values of these currents, let us know more about the construction of shunt resistance. The basic properties of shunt resistance are written below,

The electrical resistance of these shunts should not differ at higher temperature, if they should possess very low value of temperature coefficient. Also the resistance should be time independent. Last and the most important property they should possess is that they should be able to carry high value of electric current without much rise in temperature. Usually manganin is used for making dc resistance. Thus we can say that the value of I_s is much greater than the value of I_m as resistance of shunt is low. From the we have,

$$I_s \cdot R_s = I_m \cdot R_m$$

Where R_s is resistance of shunt and R_m is the electrical resistance of the coil.

$$\text{Also } I_s = I - I_m$$

From the above two equations we can write,

$$m = \frac{I}{I_m} = 1 + \frac{R_m}{R_s}$$

Where m is the magnifying power of the shunt.

Errors in Permanent Magnet Moving Coil Instruments

There are three main types of errors:

(a) Errors due to permanent magnets: Due to temperature effects and aging of the magnets the magnet may lose their magnetism to some extent. The magnets are generally aged by the heat and vibration treatment.

(b) Error may appear in PMMC Instrument due to the aging of the spring. However the error caused by the aging of the spring and the errors caused due to permanent magnet are opposite to each other, hence both the errors are compensated with each other.

(c) Change in the resistance of the moving coil with the temperature: Generally the temperature coefficients of the value of coefficient of copper wire in moving coil is 0.04 per degree celsius rise in temperature. Due to lower value of temperature coefficient the temperature rises at faster rate and hence the resistance increases. Due to this significant amount of error is caused.

Advantages of Permanent Magnet Moving Coil Instruments

(1) The scale is uniformly divided as the electric current is directly proportional to deflection of the pointer. Hence it is very easy to measure quantities from these instruments.

(2) Power consumption is also very low in these types of instruments.

(3) Higher value of torque is to weight ratio.

(4) These are having multiple advantages, a single instrument can be used for measuring various quantities by using different values of shunts and multipliers.

Instead of various advantages the permanent magnet moving coil instruments or PMMC Instrument possess few disadvantages.

Disadvantages of Permanent Magnet Moving Coil Instruments

(1) These instruments cannot measure ac quantities.

(2) Cost of these instruments is high as compared to moving iron instruments.

Moving Iron Instrument:

This instrument is one of the most primitive forms of measuring and relay instrument. Moving iron type instruments are of mainly two types. Attraction type and repulsion type instrument.

Whenever a piece of iron is placed nearer to a magnet it would be attracted by the magnet. The force of this attraction depends upon the strength said magnetic field. If the magnet is electromagnet then the magnetic field strength can easily be increased or decreased by increasing or decreasing electric current through its coil. Accordingly the attraction force acting on the piece of iron would also be increased and decreased. Depending upon this simple phenomenon attraction type **moving iron instrument** was developed.

Whenever two pieces of iron are kept side by side and a magnet is brought nearer to them the iron pieces will repulse each other. This repulsion force is due to same magnetic poles induced in same sides the iron pieces due external magnetic field. This repulsion force increases if field strength of the magnet is increased. Like case if the magnet is electromagnet, then magnetic field strength can easily be controlled by controlling input electric current to the magnet. Hence if the electric current increases the repulsion force between the pieces of iron is increased and it

the electric current decreases the repulsion force between them is decreased. Depending upon this phenomenon repulsion type **moving iron instrument** was constructed.

Construction of Moving Iron Instrument

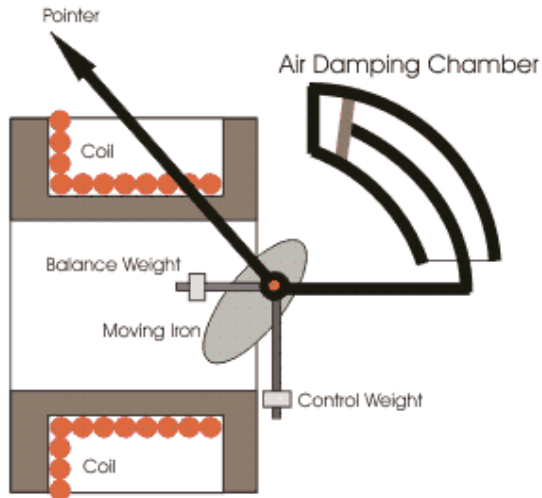

Attraction type moving iron instrument

The basic construction of attraction type moving iron instrument is illustrated below. A thin disc of soft iron is eccentrically pivoted in front of a coil. This iron tends to move inward that is from weaker magnetic field to stronger magnetic field when electric current flowing through the coil. In attraction moving instrument gravity control was used previously but now gravity control method is replaced by spring control in relatively modern instrument. By adjusting balance weight null deflection of the pointer is achieved. The required damping force is provided in this instrument by air friction. The figure shows a typical type of damping system provided in the instrument, where damping is achieved by a moving piston in an air syringe.

Theory of Attraction Type Moving Iron Instrument

Suppose when there is no electric current through the coil, the pointer is at zero, the angle made by the axis of the iron disc with the line perpendicular to the field is ϕ . Now due electric current I and corresponding magnetic field strength, the iron piece is deflected to an angle θ . Now component of H in the direction of deflected iron disc axis is $H\cos(90 - (\theta + \phi))$ or $H\sin(\theta + \phi)$. Now force F acting on the disc inward to the coil is thus proportional to $H^2\sin(\theta + \phi)$ hence the force is also proportional to $I^2\sin(\theta + \phi)$ for constant permeability. If this force is acting on the disc at a distance l from the pivot, then deflection torque,

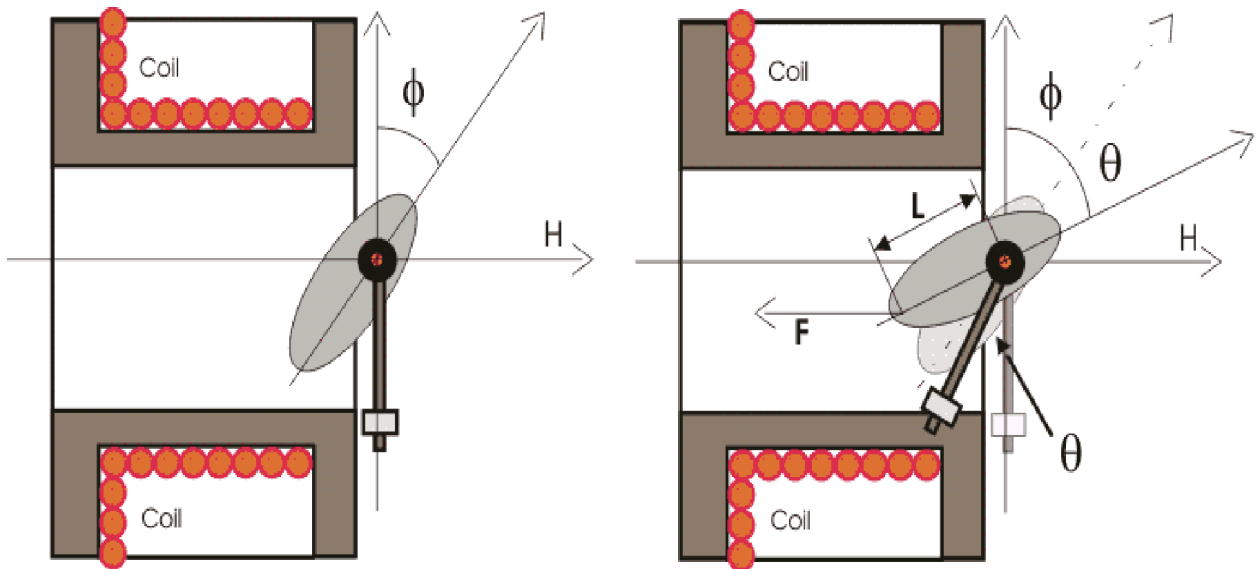

Working of Moving Iron Instrument

$$T_d = Fl \cos(\theta + \phi)$$

$$\text{Thus } T_d \propto I^2 \sin(\theta + \phi) \cos(\theta + \phi) \propto I^2 \sin 2(\theta + \phi)$$

Since l is constant.

$$T_d = kI^2 \sin 2(\theta + \phi)$$

Where k is constant.

Now, as the instrument is gravity controlled, controlling torque will be

$$T_c = k' \sin \theta$$

Where k' is constant.

At steady state condition,

CHAPTER 6

TRANSDUCERS AND SENSORS

METHOD OF SELECTING TRANSDUCERS

While selecting the proper transducer for any applications, or ordering the transducers the following specifications should be thoroughly considered.

- 1) Ranges available
- 2) Squaring System
- 3) Sensitivity
- 4) Maximum working temperature
- 5) Method of cooling employed
- 6) Mounting details
- 7) Maximum depth
- 8) Linearity and hysteresis
- 9) Output for zero input
- 10) Temperature co-efficient of zero drift
- 11) Natural Frequency.

ADVANTAGES OF ELECTRICAL TRANSDUCERS

1. Very small power is required for controlling the electrical or electronic system
2. The electrical output can be amplified to any desired level
3. Mass inertia effects are reduced to minimum possible.
4. The size and shape of the transducers can be suitably designed to achieve the optimum weight and volume
5. The output can be indicated and recorded remotely at a distance from the sensing medium .
6. The outputs can be modified to meet the requirements of the indicating or controlling equipment.

RESISITIVE TRANSDUCERS

The resistance of a conductor is expressed by a simple equation that involves a few physical quantities . The relationship is given by

$$R = \rho L / A$$

Where , R= resistance, Ω

ρ = Resistivity of conductor materials, $\Omega\text{-m}$

L= Length of conductor, m

A = Cross sectional area of the conductor, m^2

Any method of varying one of the quantities involved in the above relationship can be the designed basis of an electrical resistance transducer. There are a number of ways in which resistance can be changed by a physical phenomenon.

The translational and rotational potentiometer which work on the basis of change in the value of resistance with change in length of the conductor can be used for measurement of translational or rotary displacements

The resistivity of materials changes with the change of temperature thus causing a change of resistance. This property may be used for measurement of temperature.

In a resistance transducer an indication of measured physical quantity is given by a change in the resistance. It may be classified as follows

1. Mechanically varied resistance - POTENTIOMETER
2. Thermal resistance change – RESISTANCE THERMOMETER
3. Resistivity change - RESISTANCE STRAIN GAUGE

STRAIN GAUGE

INTRODUCTION

When a metal conductor is stretched or compressed , its resistance changes on account of the fact that both length and diameter of conductor change . The value of resistivity of conductor also changes. When it is strained it's property is called **piezo-resistance** . Therefore , resistance strain gauges are also known as **piezo- resistive gauges** .

The strain gauge is a measurement transducer for measuring strain and associated stress in experimental stress analysis.

TYPES

Four types of Strain gauges are :

1. Wire –wound strain gauge
2. Foil-type strain gauge
3. Semiconductor strain gauge
4. Capacitive strain gauge.

DIAGRAM WIRE-WOUND STRAIN GAUGE

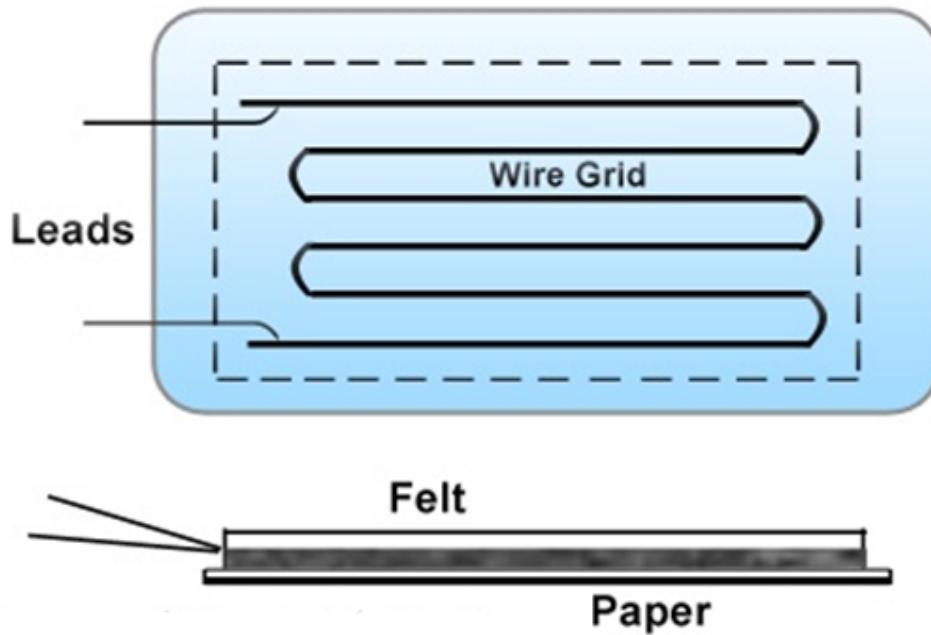

WORKING PRINCIPLE

Strain gauges work on the principle that the resistance of a conductor or a semiconductor changes when strained. This property can be used for measurement of displacement, force and pressure.

When a strain gauge is subjected to tension (positive strain) its length increases while its cross sectional area decreases. Since the resistance of a conductor is proportional to its length and inversely proportional to its area of cross section, The resistance of the gauge increases with positive strain.

Strain gauges are most commonly used in **wheat-stone bridge** circuits to measure the change of resistance of grid of wire for calibration purposes; the '**GAUGE FACTOR**' is defined as the ratio of per unit change in resistance to per unit change in length.

i.e , Gauge factor (Gf) = $\Delta R/R \div \Delta L/L$

Where, ΔR = corresponding change in resistance, R

ΔL = Change in length per unit length, L

$$R = \rho L/A$$

Where, R= resistance, Ω

ρ = Resistivity of conductor materials, $\Omega\text{-m}$

L= Length of conductor, m

A = Cross sectional area of the conductor, m^2

L.V.D.T

LVDT is a passive inductive transducer and is commonly employed to measure force (or weight, pressure and acceleration etc. Which depend on force) in terms of the amount and direction of displacement of an object.

WORKING PRINCIPLE

When the core is in the centre (called reference position) the induced voltages E_1 and E_2 are equal and opposite. Hence they cancel out and the output voltages V_o is zero.

When the external applied force moves the core towards the coil S_2 , E_2 is increased but E_1 is decreased in magnitude though they are still antiphase with each other. The net voltage available is $(E_2 - E_1)$ and is in phase with E_2 .

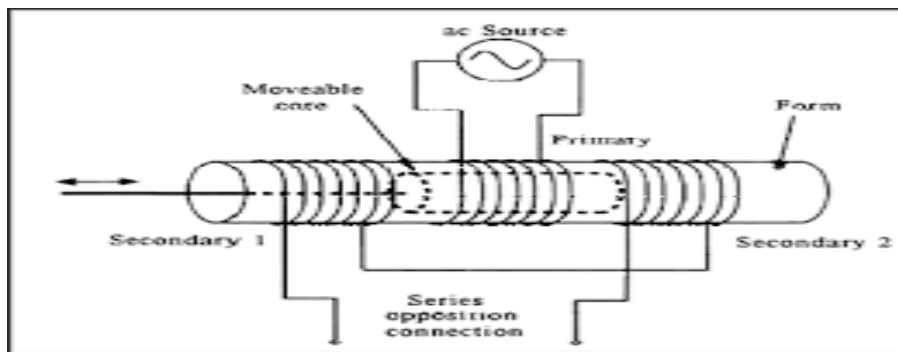

Similarly, When movable core moves towards coil S_1 , $E_1 > E_2$ and $V_o = E_1 - E_2$ and is in phase with E_1 .

ADVANTAGES

1. It gives a high output and therefore many a times there is no need for intermediate amplification devices.
2. The transducer possess a high sensitivity as high as 40V/mm
3. It shows a low hysteresis and hence repeatability is excellent under all conditions.
4. Most of the LVDTs consume a power of less than 1W.
5. Less friction and less noise .

DISADVANTAGES

1. These transducers are sensitive to stray magnetic fields but shielding is possible .This is done by providing magnetic shields with longitudinal slots.
2. Relatively large displacements are required for appreciable differential output.
3. Several times, the transducer performance is affected by vibrations.

APPLICATIONS

1. Measurement of material thickness in hot strip or slab steel mills
2. In accelerometers.
3. Jet engine controls in close proximity to exhaust gases.

CAPACITIVE TRANSDUCER (PRESSURE)

A linear change in capacitance with changes in the physical position of the moving element may be used to provide an electrical indication of the element's position.

The capacitance is given by $C = KA/d$

where K = the dielectric constant
 A = the total area of the capacitor surfaces
 d = distance between two capacitive surfaces
 C = the resultant capacitance.

From this equation, it is seen that capacitance increases (i) if the effective area of the plate is increased, and (ii) if the material has a high dielectric constant.

The capacitance is reduced if the spacing between the plates is increased.

Transducers which make use of these three methods of varying capacitance have been developed.

With proper calibration, each type yields a high degree of accuracy. Stray magnetic and capacitive effects may cause errors in the measurement produced, which can be avoided by proper shielding. Some capacitive dielectrics are temperature sensitive, so temperature variations should be minimised for accurate measurements.

A variable plate area transducer is made up of a fixed plate called Stator and a movable plate called the Rotor.

The rotor is mechanically coupled to the member under test. As the member moves, the rotor changes its position relative to the stator, thereby changing the effective area between the plates. A transducer of this type is shown in Fig. 13.28.

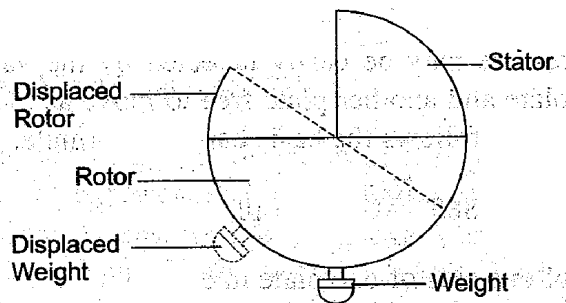

Fig. 13.28 Capacitive Transducer

Such a device is used to detect the amount of roll in an aircraft. As the aircraft rolls to the left, the plates moves to the relative position shown by dashed lines in Fig. 13.28 and the capacitance decreases by an amount proportional to the degree of roll. Similarly to the right. In this case the stator, securely attached to the aircraft, is the moving element. The weight on the rotor keeps its position fixed with reference to the surface of the earth, but the relative position of the plates changes and this is the factor that determines the capacitance of the unit.

Figure 13.29 shows a transducer that makes use of the variation in capacitance resulting from a change in spacing between the plates. This particular transducer is designed to measure pressure (in vacuum).

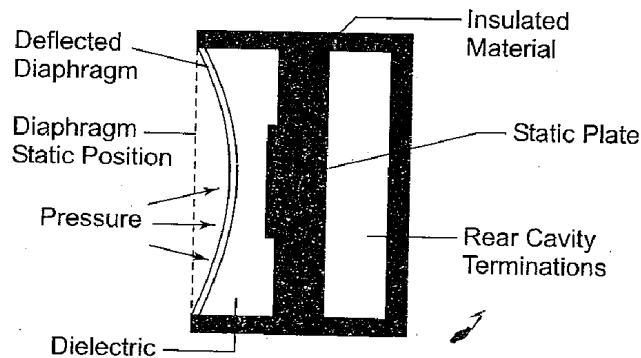

Fig. 13.29 Capacitive Pressure Transducer

Enclosed in an airtight container is a metallic diaphragm which moves to the left when pressure is applied to the chamber and to the right when vacuum is applied. This diaphragm is used as one plate of a variable capacitor. Its distance from the stationary plate to its left, as determined by the pressure applied to the unit, determines the capacitance between the two plates. The monitor indicates the pressure equivalent of the unit's capacitance by measuring the capacitor's reactance to the ac source voltage.

(The portion of the chamber to the left of the moving plate is isolated from the side into which the pressurised gas or vapour is introduced. Hence, the dielectric constant of the unit does not change for different types of pressurised gas or vapour. The capacity is purely a function of the diaphragm position.) This device is not linear.

Changes in pressure may be easily detected by the variation of capacity between a fixed plate and another plate free to move as the pressure changes. The resulting variation follows the basic capacity formula.

$$C = 0.885 \frac{K(n-1)A}{t} \text{ pf} \quad (13.15)$$

where A = area of one side of one plate in cm^2

n = number of plates

t = thickness of dielectric in cm

LOAD CELLS

Load cells are sensors which are used to measure the level or pressure by converting the force (torque or mass) into electrical signals and then these signals are displayed by the display unit to show the level or pressure. Load cells are also known as load transducers. In dictionary, a load cell is known as “weight measuring device necessary for electronic signal that displays weight in the form of digits.”

Load cells can be classified according to their operations:

- Load cells that utilize liquid pressure or air pressure.
- Load cells that utilize elasticity.
- Load cells that utilize a magnetostriction or piezoelectric effect.

The strain gauge load cell is the mostly used among the all kinds of load cells. Therefore, when we say “load cell,” we are mostly referring to strain gauge load cells. Although there are many other measurement devices, such as piezoelectric sensors, Magnetostrictive sensors, capacitance sensor and other sensors.

1.2-Types of Load cells

- Strain gauge load cells
- Tension load cells
- Pneumatic load cells
- Hydraulic load cells

Strain Gauge Load Cells

This is a type of load cell which is use to measure the level of any storage vessel. When pressure is applied on a conductor its length changes due to which resistance of the conductor changes and relative to the change in resistance display unit displays the change in level.

A strain gauge is consists of a long length conductor which is arranged in zigzag way on the flexible membrane which is exposed to the applied pressure area. This conductor is connected in a wheat stone bridge as a resistor and when pressure or weight is applied on the membrane which is connected to the conductor it gets stretched and due to stretching the length of the conductor changes and due to change in length the resistance of the conductor increases.

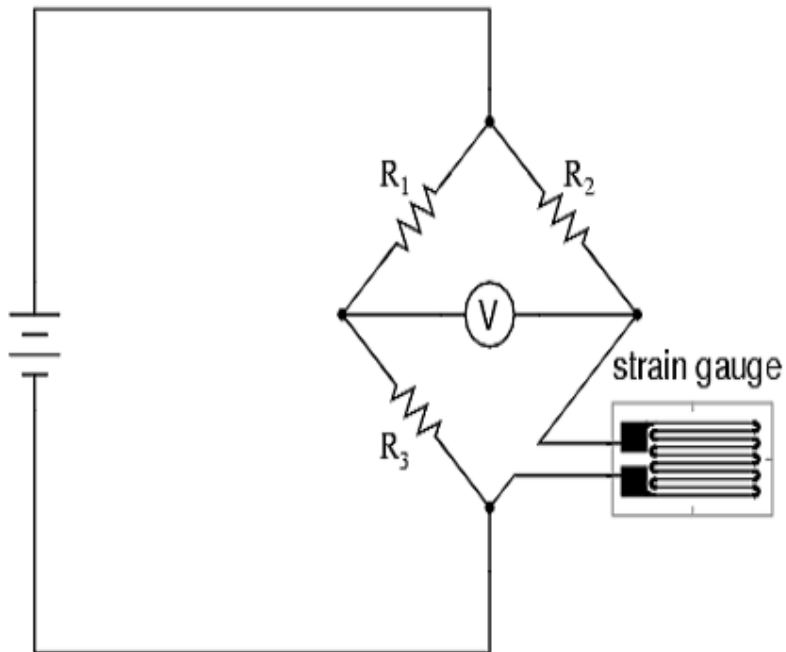
Quarter-bridge strain gauge circuit

Pneumatic Load Cells

This is another type of load cells which are used to measure the weight in the industry and these are used for low capacity. This type of load cells works on “the force-balance principle.” Which means

The inertial force produced by a seismic ground motion shifts the mass from its original equilibrium position, and the change in position or velocity of the mass is then interpreted into an electric signal. This principle is for low range load cells. For long range load cells the inertial force is balanced with an electrically generated force so that the mass moves as low as possible.

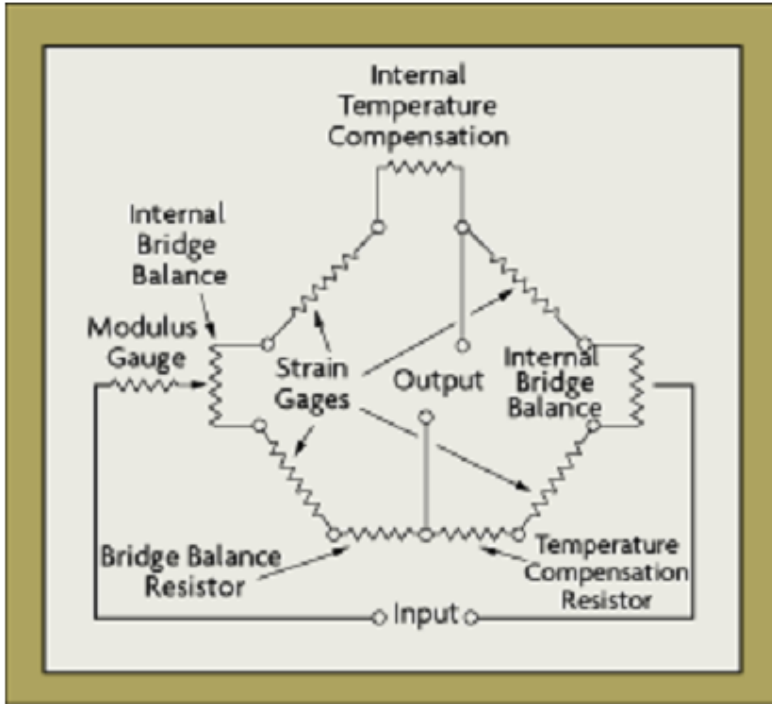

This kind of load cells consist of a sensing element which is exposed to the site or the vessel of which pressure or lying fluid weight is to be measured. And in this kind of load cell the force transferring medium is air as compare to the any other fluid in case of hydraulic load cell. When force is applied by the lying fluid on the sensing part of the load cell it transfers this force to the inside air and then this force is applied on the potentiometer which is placed in the wheat stone bridge. As the force is applied on the sensing part of the load cell the resistance of the variable resistance potentiometer changes due to this force and thus the potential equilibrium between the resistances is disturbed and this shows the magnitude of the applied force on the sensing element by displaying it on the display unit.

Hydraulic Load Cells

This is another type of load cells which are used to measure the magnitude of the applied force and their conversion to the electric signals and its digital display. This type of load cells also work on “the force-balance principle.”The difference between the pneumatic load cell and hydraulic load cell is only the transferring medium. In case of pneumatic load cell the force transferring medium is air while in hydraulic load cells the force transferring medium is mostly liquid or incompressible oil which is also known as break oil.

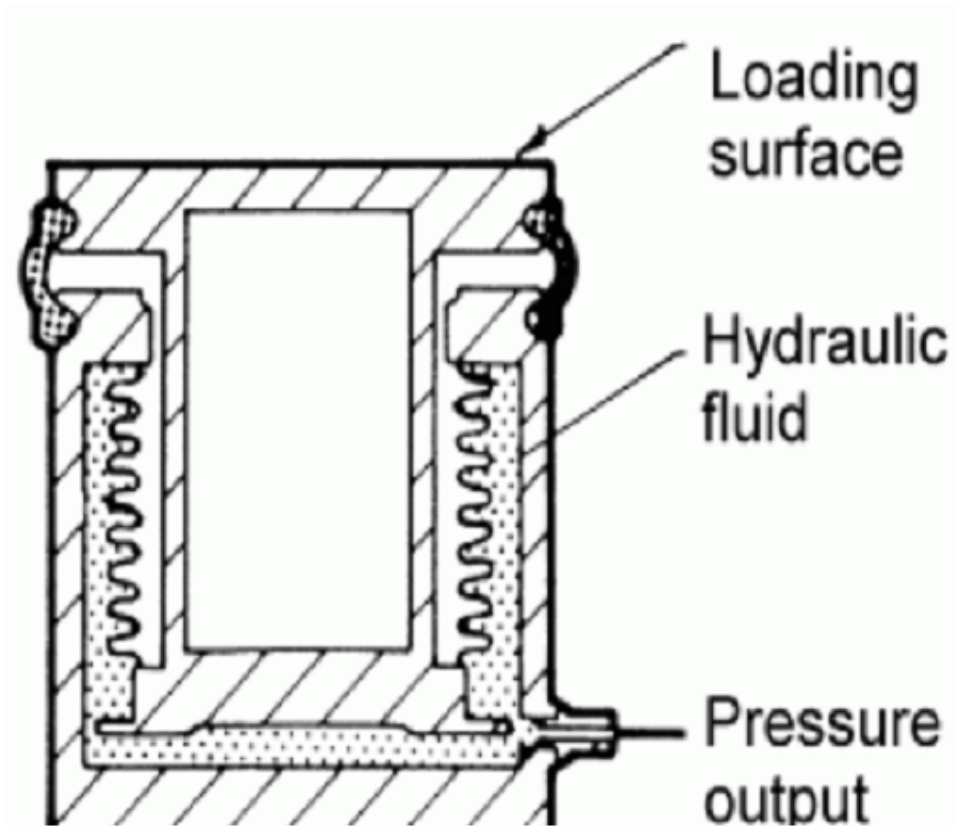

Hydraulic load cell consists of a fluid which act as a force transferring medium and a piezoelectric crystal which is use to convert this applied force into potential difference and then there is an arrangement for the conversion of this potential difference in terms of weight or pressure. There is a diaphragm which is use to sense the force exerted from the external side and the whole casing in which this complete cell is enclosed. When the pressure or weight by the vessel or column is applied on the diaphragm of the load cell it sense that force and then transfers this force to the fluid which is filled in the casing of this load cell.

TEMPERATURE TRANSDUCERS

TEMPERATURE TRANSDUCERS

13.20.1 Introduction to Temperature Transducers

Temperature is one of the most widely measured and controlled variable in industry, as a lot of products during manufacturing requires controlled temperature at various stages of processing.

A wide variety of temperature transducers and temperature measurement systems have been developed for different applications requirements.

Most of the temperature transducers are of Resistance Temperature Detectors (RTD), Thermistors and Thermocouples. Of these RTD's and Thermistor are passive devices whose resistance changes with temperature hence need an electrical supply to give a voltage output. On the other hand thermocouples are active transducers and are based on the principle of generation of thermoelectricity, when two dissimilar metals are connected together to form a junction called the *sensing junction*, an emf is generated proportional to the temperature of the junction. Thermocouple operate on the principle of *seeback effect*. Thermocouple introduces errors and can be overcome by using a reference junction compensation called as a *cold junction compensation*.

13.20.2 Resistance Temperature Detector (RTD)

Resistance temperature detector* commonly use platinum, nickel or any resistance wire whose resistance varies with temperature and which has a high intrinsic accuracy. They are available in many configuration and sizes; as shielded or open units for both immersion and surface applications.

The relationship between temperature and resistance of conductors in the temperature range near 0°C can be calculated using the equation

$$R_t = R_{\text{ref}} (1 + \alpha \Delta t)$$

where R_t = resistance of conductor at temperature $t^\circ\text{C}$

R_{ref} = resistance of the reference temperature, usually 0°C

α = temperature coefficient of resistance

Δt = difference between operating and reference temperature

Thermocouple

One of the most commonly used methods of measurement of moderately high temperature is the thermocouple effect. When a pair of wires made up of different metals is joined together at one end, a temperature difference between the two ends of the wire produces a voltage between the two wires as illustrated in Fig.13.41

Temperature measurement with Thermocouple is based on the Seebeck effect. A current will circulate around a loop made up of two dissimilar metal when the two junctions are at different temperatures as shown in Fig.13.42.

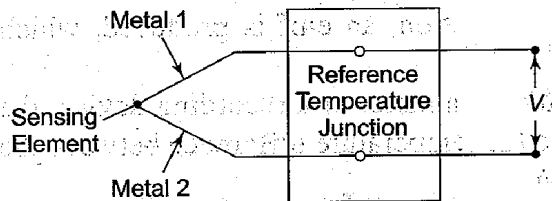

Fig. 13.41 Basic Thermocouple Connection

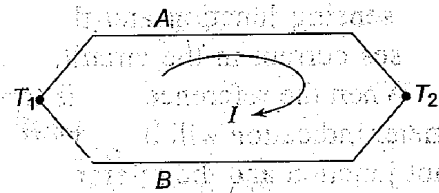

Fig. 13.42 Current through Two dissimilar Metals

When this circuit is opened, a voltage appears that is proportional to the observed seebeck current.

There are four voltage sources, their sum is the observed seebeck voltage. Each junction is a voltage source, known as *Peltier emf*. Furthermore, each homogenous conductor has a self induced voltage or Thomson emf.

The Thomson and Peltier emfs originate from the fact that, within conductors, the density of free charge carriers (electrons and holes) increases with temperature.

(If the temperature of one end of a conductor is raised above that of the other end, excess electrons from the hot end will diffuse to the cold end. This results in an induced voltage, the *Thomson effect*, that makes the hot end positive with respect to the cold end.

Conductors made up of different materials have different free-carriers densities even when at the same temperature. When two dissimilar conductors are joined, electrons will diffuse across the junction from the conductor with higher electron density. When this happens the conductor losing electrons acquire a positive voltage with respect to the other conductor. This voltage is called the *Peltier emf*.)

reference temperature, or in the case of very low cost equipment at room temperature. In the latter case, the room temperature is monitored and thermocouple output voltage readings are corrected for any changes in it.

Because the temperature at this end of the thermocouple wire is a reference temperature, this function is known as the reference, also called as the *cold junction*.

A thermocouple, therefore consists of a pair of dissimilar metal wires joined together at one end (sensing or hot junction) and terminated at the other end (reference or cold junction), which is maintained at a known constant temperature (reference temperature). When a temperature difference exists between the sensing junction and the reference junction, an emf is produced, which causes current in the circuit.

When the reference end is terminated by a meter or a recording device, the meter indication will be proportional to the temperature difference between the hot junction and the reference junction.

The magnitude of the thermal emf depends on the wire materials used and in the temperature difference between the junctions.

Figure 13.43 shows the thermal emfs for some common thermocouple materials. The values shown are based on a reference temperature of 32°F.

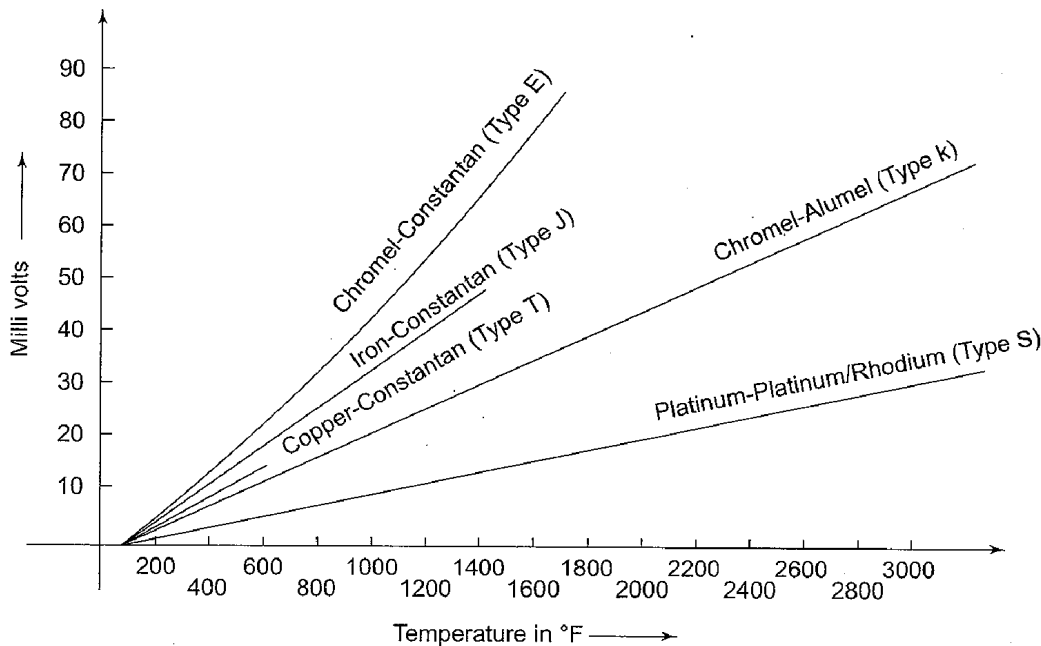

Fig. 13.43 Thermocouple Output Voltage as a Function of Temperature for Various Thermocouple materials

The thermocouple (TC) is a temperature transducer that develops an emf that is a function of the temperature difference between its hot and cold junctions.

A thermocouple may be regarded as a thermometer based on thermo-emf and works on the principle that the potential between two dissimilar metals or metal alloys is a function of temperature.

Optical Pyrometer

Any metallic surface when heated emits radiation of different wavelengths which are not visible at low temperature but at about 550 °C, radiations in shorter wavelength are visible to eye and from the colour approximate temperature is measured. The approximate values of temperature for colour (colour scale) is given in Table 13.4.

Table 13.4 Colour Scale

Dark Red	540°C
Medium Cherry Red	680°C
Orange	900°C
Yellow	1010°C
White	1205°C

The radiations from a heated body at high temperature fall within the visible region of the EM spectrum. For a given wavelength in the visible region the energy radiated is greater than at higher temperature.

Within a visible range, a given wavelength has a fixed colour and the energy of radiation is interpreted as Intensity or Brightness. Hence if we measure the brightness of the light of a given colour emitted by a hot source, we have an indication of temperature. This is the principle of optical pyrometer.

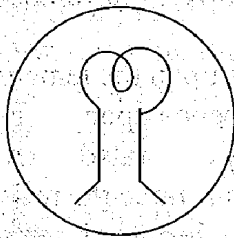

(a) Filament colder than background

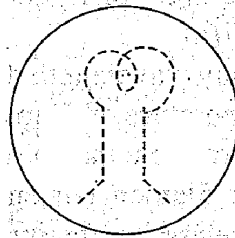

(b) Filament invisible against background

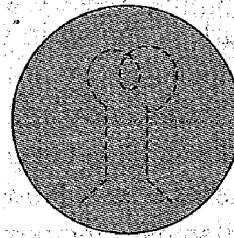

(c) Filament and background having equal brightness

In an optical pyrometer, the wavelength of radiation accepted is restricted by means of a colour filter and brightness is measured by comparison with a standard lamp.

The most common type of optical pyrometer used is the disappearing filament pyrometer. The schematic is shown in Fig.13.58.

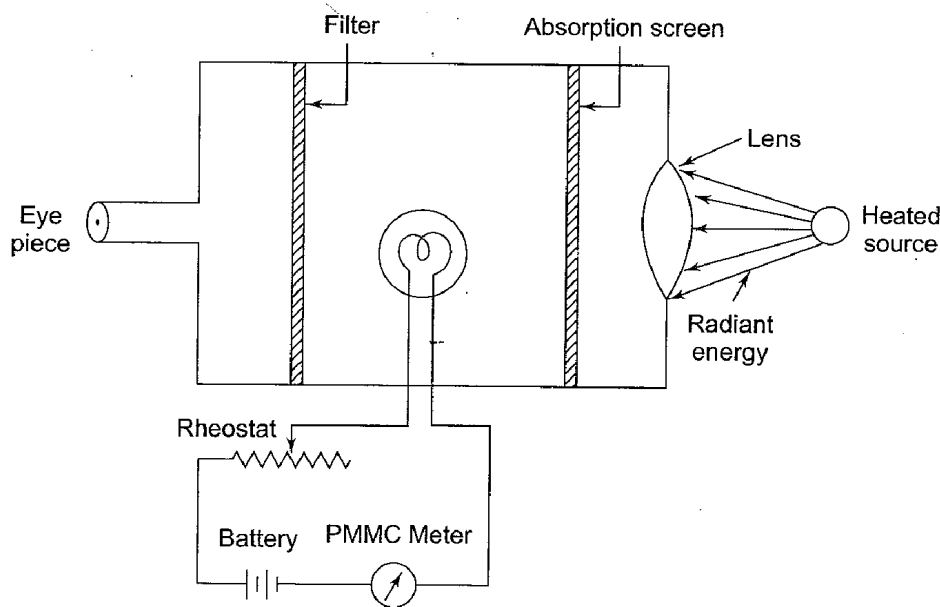

Fig.13.58

An image of the radiating source is produced by a lens and made to coincide with the filament of an electric lamp.

The current through the lamp filament is made variable so that the lamp intensity can be adjusted. The filament is viewed through an eye piece and filters. The current through the filament is adjusted until the filament and the images are of equal brightness.

When brightness of image produced by the source and brightness produced by the filament are equal, the outline of the filament disappears as shown in Fig.13.57(c).

However, if the temperature of the filament is higher than that required for equality of brightness, filament becomes too bright as shown in Fig.13.57(b).

On the other hand if the temperature of filament is lower, the filament becomes dark as shown in Fig.13.57(a).

Since the intensity of light of any wavelength depends upon the temperature of the radiating body and the temperature of filament depends upon the current flowing through the lamp. The instrument may be directly calibrated in terms of the filament current. However, the filament current depends upon the resistance of the filament, modern pyrometers are calibrated in terms of resistance directly.

The range of temperature, which can be measured by an instrument of this type depends on the maximum allowable temperature of the lamp which is around 1400 °C.

PROXIMITY SENSORS

A **proximity sensor** is a [sensor](#) able to detect the presence of nearby objects without any physical contact.

A proximity sensor often emits an [electromagnetic](#) field or a beam of [electromagnetic radiation](#) ([infrared](#), for instance), and looks for changes in the [field](#) or return signal. The object being sensed is often referred to as the proximity sensor's target. Different proximity sensor targets demand different sensors. For example, a [capacitive](#) or [photoelectric sensor](#) might be suitable for a plastic target; an [inductive](#) proximity sensor always requires a metal target.

The maximum distance that this sensor can detect is defined "nominal range". Some sensors have adjustments of the nominal range or means to report a graduated detection distance.

Proximity sensors can have a high reliability and long functional life because of the absence of mechanical parts and lack of physical contact between sensor and the sensed object.

Proximity sensors are commonly used on smart phones to detect (and skip) accidental touch screen taps when held to the ear during a call.^[1] They are also used in machine vibration monitoring to measure the variation in distance between a shaft and its support bearing. This is common in large steam [turbines](#), [compressors](#), and motors that use sleeve-type [bearings](#).

International Electro technical Commission (IEC) 60947-5-2 defines the technical details of proximity sensors.

A proximity sensor adjusted to a very short range is often used as a [touch switch](#).

This presence detector or proximity sensor circuit reacts in presence of any conductor object including humans. Sensitivity is adjustable with P1 which will be located at a great distance from the rest of the presence detector circuit. This circuit does not detect object movement but can act as an proximity sensor!

Presence, Proximity Sensor Circuit Schematic

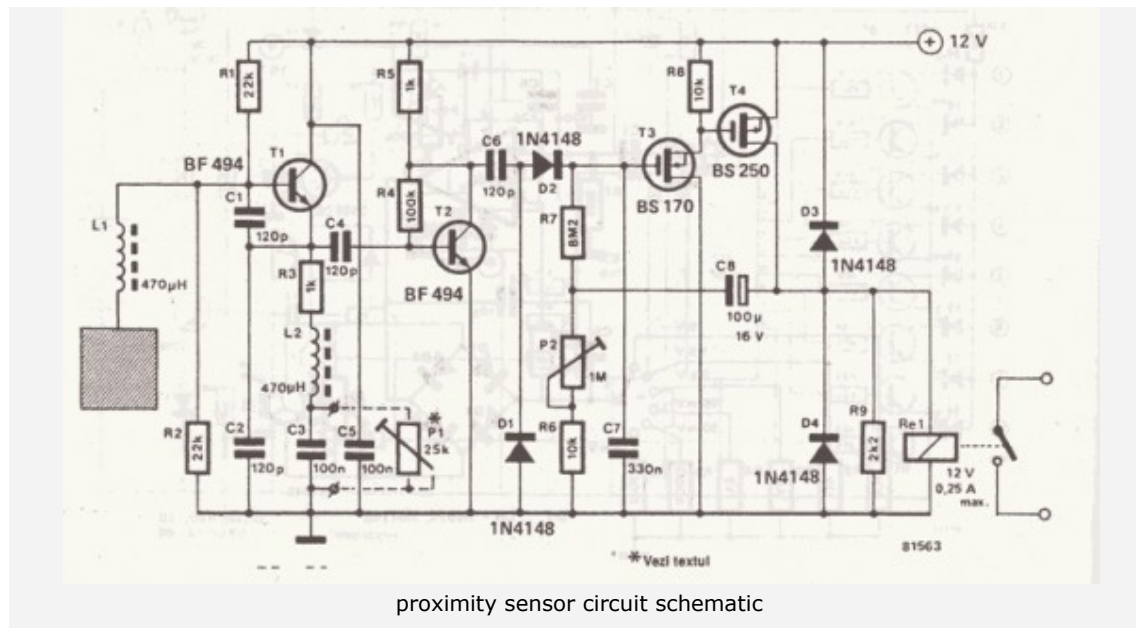

The sensitivity of the proximity sensor circuit can be adjusted with P1 for the desired “distance”. One of its obvious uses is to open a door automatically. For this the sensor must be placed on the front of the door.

The presence detector is made of one oscillator with T1 and a mono-stable. The oscillator is a Clapp one, well known for its frequency stability. The surface of the sensor acts as a capacitor for the oscillator circuit and in this configuration the frequency is around 1 MHz.

The switching time can be adjusted with P2. Do not bring metallic objects in the proximity of the circuit because if doing so the relay will stay closed! This circuit can be used as a detector of aggressive liquids, the advantage being that the surface of the sensor will not come in contact with the liquid.

Light Sensors

A Light Sensor generates an output signal indicating the intensity of light by measuring the radiant energy that exists in a very narrow range of frequencies basically called “light”, and which ranges in frequency from “Infra-red” to “Visible” up to “Ultraviolet” light spectrum.

The [Light Sensor](#) is a passive devices that convert this “light energy” whether visible or in the infra-red parts of the spectrum into an electrical signal output.

Light sensors are more commonly known as “Photoelectric Devices” or “Photo Sensors” because they convert light energy (photons) into electricity (electrons).

Photoelectric devices can be grouped into two main categories, those which generate electricity when illuminated, such as *Photo-voltaics* or *Photo-emissives* etc, and those which change their electrical properties in some way such as *Photo-resistors* or *Photo-conductors*. This leads to the following classification of devices.

- **Photo-emissive Cells** – These are photodevices which release free electrons from a light sensitive material such as caesium when struck by a photon of sufficient energy. The amount of energy the photons have depends on the frequency of the light and the higher the frequency, the more energy the photons have converting light energy into electrical energy.
- **Photo-conductive Cells** – These photodevices vary their electrical resistance when subjected to light. Photoconductivity results from light hitting a semiconductor material which controls the current flow through it. Thus, more light increases the current for a given applied voltage. The most common photoconductive material is Cadmium Sulphide used in LDR photocells.
- **Photo-voltaic Cells** – These photodevices generate an emf in proportion to the radiant light energy received and is similar in effect to photoconductivity. Light energy falls on to two semiconductor materials sandwiched together creating a voltage of approximately 0.5V. The most common photovoltaic material is Selenium used in solar cells.
- **Photo-junction Devices** – These photo devices are mainly true semiconductor devices such as the photodiode or phototransistor which use light to control the flow of electrons and holes across their PN-junction. Photo junction devices are specifically designed for detector application and light penetration with their spectral response tuned to the wavelength of incident light.

The Photoconductive Cell

A **Photoconductive** light sensor does not produce electricity but simply changes its physical properties when subjected to light energy. The most common type of photoconductive device is the *Photo resistor* which changes its electrical resistance in response to changes in the light intensity.

Photo resistors are **Semiconductor** devices that use light energy to control the flow of electrons, and hence the current flowing through them. The commonly used *Photoconductive Cell* is called the **Light Dependent Resistor** or **LDR**.

The Light Dependent Resistor



Typical LDR

As its name implies, the **Light Dependent Resistor** (LDR) is made from a piece of exposed semiconductor material such as cadmium sulphide that changes its electrical resistance from several thousand Ohms in the dark to only a few hundred Ohms when light falls upon it by creating hole-electron pairs in the material.

The net effect is an improvement in its conductivity with a decrease in resistance for an increase in illumination. Also, photo resistive cells have a long response time requiring many seconds to respond to a change in the light intensity.

Materials used as the semiconductor substrate include, lead sulphide (PbS), lead selenide (PbSe), indium antim-onide (InSb) which detect light in the infra-red range with the most commonly used of all photoresistive light sensors being **Cadmium Sulphide (Cds)**.

Cadmium sulphide is used in the manufacture of photoconductive cells because its spectral response curve closely matches that of the human eye and can even be controlled using a simple torch as a light source. Typically then, it has a peak sensitivity wavelength (λ_p) of about 560nm to 600nm in the visible spectral range.

The Light Dependent Resistor Cell

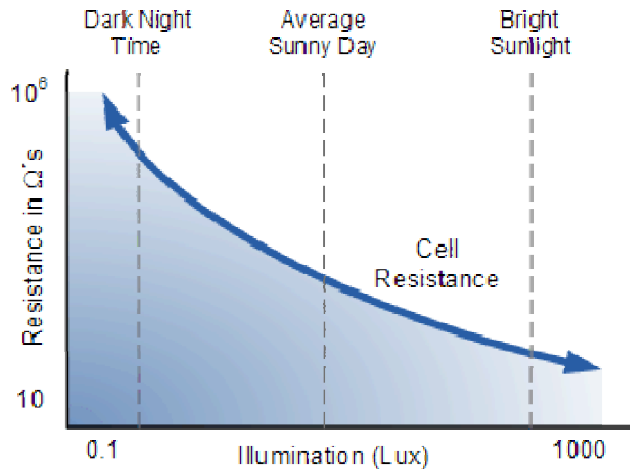
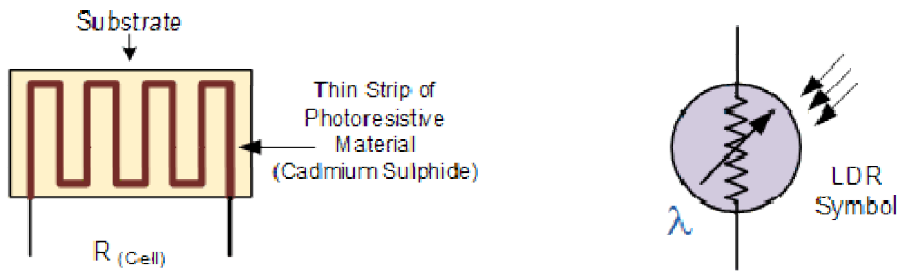

The most commonly used photoresistive light sensor is the **ORP12** Cadmium Sulphide photoconductive cell. This light dependent resistor has a spectral response of about 610nm in the yellow to orange region of light. The resistance of the cell when unilluminated (dark resistance) is very high at about 10MΩ's which falls to about 100Ω's when fully illuminated (lit resistance).

To increase the dark resistance and therefore reduce the dark current, the resistive path forms a zigzag pattern across the ceramic substrate. The CdS photocell is a very low cost device often used in auto dimming, darkness or twilight detection for turning the street lights “ON” and “OFF”, and for photographic exposure meter type applications.

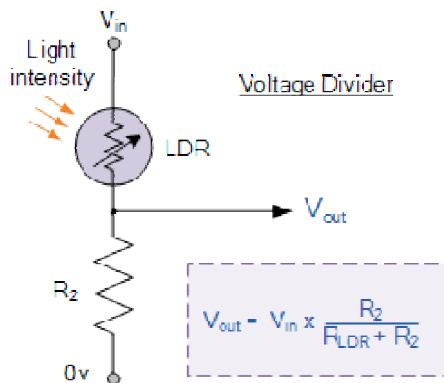

Connecting a light dependant resistor in series with a standard resistor like this across a single DC supply voltage has one major advantage, a different voltage will appear at their junction for different levels of light.

The amount of voltage drop across series resistor, R_2 is determined by the resistive value of the light dependant resistor, R_{LDR} . This ability to generate different voltages produces a very handy circuit called a “Potential Divider” or **Voltage Divider Network**.

As we know, the current through a series circuit is common and as the LDR changes its resistive value due to the light intensity, the voltage present at V_{OUT} will be determined by the voltage divider formula. An LDR's resistance, R_{LDR} can vary from about 100Ω 's in the sun light, to over $10M\Omega$'s in absolute darkness with this variation of resistance being converted into a voltage variation at V_{OUT} as shown.

One simple use of a *Light Dependent Resistor*, is as a light sensitive switch as shown below.

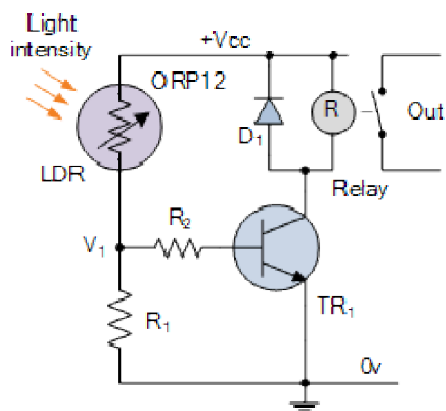

LDR Switch

This basic light sensor circuit is of a relay output light activated switch. A potential divider circuit is formed between the photoresistor, **LDR** and the resistor **R1**. When no light is present ie in darkness, the resistance of the **LDR** is very high in the Megaohms ($M\Omega$'s) range so zero base bias is applied to the transistor **TR1** and the relay is de-energised or “OFF”.

As the light level increases the resistance of the **LDR** starts to decrease causing the base bias voltage at **V1** to rise. At some point determined by the potential divider network formed with resistor **R1**, the base bias voltage is high enough to turn the transistor **TR1** “ON” and thus activate the relay which in turn is used to control some external circuitry. As the light level falls back to darkness again the resistance of the **LDR** increases causing the base voltage of the transistor to decrease, turning the transistor and relay “OFF” at a fixed light level determined again by the potential divider network.

By replacing the fixed resistor **R1** with a potentiometer **VR1**, the point at which the relay turns “ON” or “OFF” can be pre-set to a particular light level. This type of simple circuit shown above has a fairly low sensitivity and its switching point may not be consistent due to variations in either temperature or the supply voltage. A more sensitive precision light activated circuit can be easily made by incorporating the LDR into a “Wheatstone Bridge” arrangement and replacing the transistor with an **Operational Amplifier** as shown.

Light Level Sensing Circuit

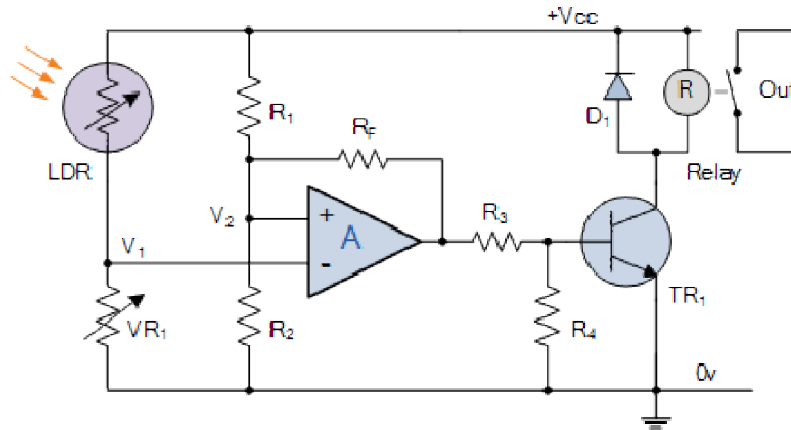

In this basic dark sensing circuit, the light dependent resistor **LDR1** and the potentiometer **VR1** form one adjustable arm of a simple resistance bridge network, also known commonly as a *Wheatstone bridge*, while the two fixed resistors **R1** and **R2** form the other arm. Both sides of the bridge form potential divider networks across the supply voltage whose outputs **V1** and **V2** are connected to the non-inverting and inverting voltage inputs respectively of the operational amplifier.

The operational amplifier is configured as a **Differential Amplifier** also known as a voltage comparator with feedback whose output voltage condition is determined by the difference between the two input signals or voltages, **V1** and **V2**. The resistor combination **R1** and **R2** form a fixed voltage reference at input **V2**, set by the ratio of the two resistors. The **LDR – VR1** combination provides a variable voltage input **V1** proportional to the light level being detected by the photoresistor.

As with the previous circuit the output from the operational amplifier is used to control a relay, which is protected by a free wheel diode, **D1**. When the light level sensed by the LDR and its output voltage falls below the reference voltage set at **V2** the output from the op-amp changes state activating the relay and switching the connected load.

Likewise as the light level increases the output will switch back turning “OFF” the relay. The hysteresis of the two switching points is set by the feedback resistor R_f can be chosen to give any suitable voltage gain of the amplifier.

The operation of this type of light sensor circuit can also be reversed to switch the relay “ON” when the light level exceeds the reference voltage level and vice versa by reversing the positions of the light sensor LDR and the potentiometer VR1. The potentiometer can be used to “pre-set” the switching point of the differential amplifier to any particular light level making it ideal as a simple light sensor project circuit.

Photojunction Devices

Photojunction Devices are basically **PN-Junction** light sensors or detectors made from silicon semiconductor PN-junctions which are sensitive to light and which can detect both visible light and infra-red light levels. Photo-junction devices are specifically made for sensing light and this class of photoelectric light sensors include the *Photodiode* and the *Phototransistor*.



The Photodiode.

The construction of the **Photodiode** light sensor is similar to that of a conventional PN-junction diode except that the diodes outer casing is either transparent or has a clear lens to focus the light onto the PN junction for increased sensitivity. The junction will respond to light particularly longer wavelengths such as red and infra-red rather than visible light.

This characteristic can be a problem for diodes with transparent or glass bead bodies such as the 1N4148 signal diode. **LED's** can also be used as photodiodes as they can both emit and detect light from their junction. All PN-junctions are light sensitive and can be used in a photo-conductive unbiased voltage mode with the PN-junction of the photodiode always “Reverse Biased” so that only the diodes leakage or dark current can flow.

The current-voltage characteristic (I/V Curves) of a photodiode with no light on its junction (dark mode) is very similar to a normal signal or rectifying diode. When the photodiode is forward biased, there is an exponential increase in the current, the same as for a normal diode. When a reverse bias is applied, a small reverse saturation current appears which causes an increase of the depletion region, which is the sensitive part of the junction. Photodiodes can also be connected in a current mode using a fixed bias voltage across the junction. The current mode is very linear over a wide range.

Photo-diode Construction and Characteristics

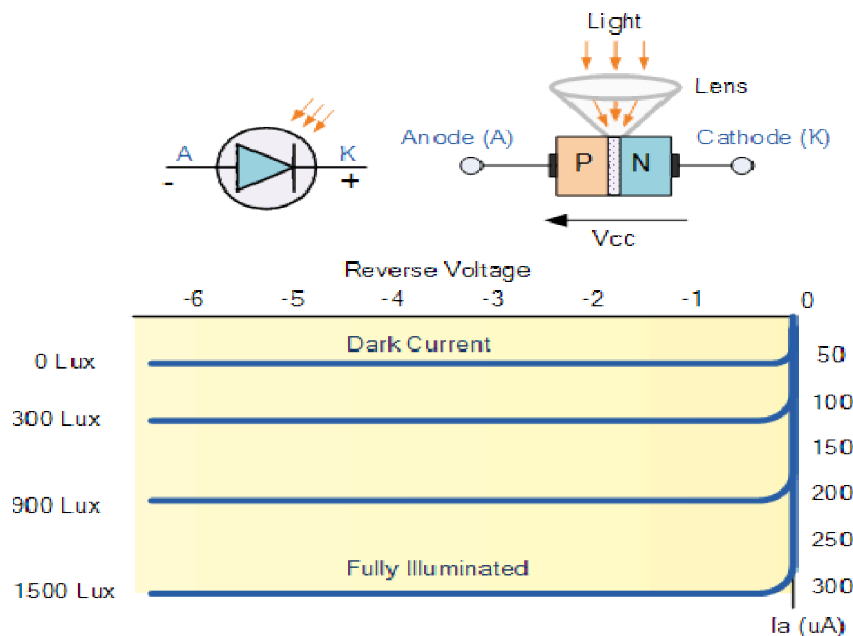

When used as a light sensor, a photodiodes dark current (0 lux) is about 10uA for geranium and 1uA for silicon type diodes. When light falls upon the junction more hole/electron pairs are formed and the leakage current increases. This leakage current increases as the illumination of the junction increases.

Thus, the photodiodes current is directly proportional to light intensity falling onto the PN-junction. One main advantage of photodiodes when used as light sensors is their fast response to changes in the light levels, but one disadvantage of this type of photodevice is the relatively small current flow even when fully lit.

The following circuit shows a photo-current-to-voltage convertor circuit using an operational amplifier as the amplifying device. The output voltage (V_{out}) is given as $V_{out} = I_p \times R_f$ and which is proportional to the light intensity characteristics of the photodiode.

This type of circuit also utilizes the characteristics of an operational amplifier with two input terminals at about zero voltage to operate the photodiode without bias. This zero-bias op-amp configuration gives a high impedance loading to the photodiode resulting in less influence by dark current and a wider linear range of the photocurrent relative to the radiant light intensity. Capacitor C_f is used to prevent oscillation or gain peaking and to set the output bandwidth ($1/2\pi RC$).

Photo-diode Amplifier Circuit

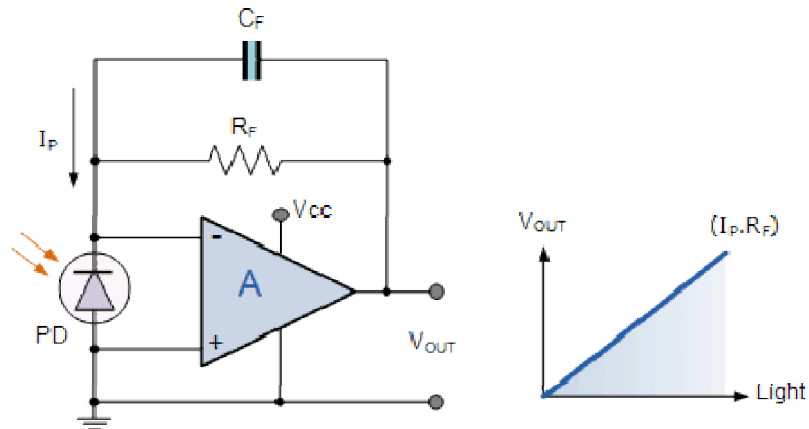

Photodiodes are very versatile light sensors that can turn its current flow both “ON” and “OFF” in nanoseconds and are commonly used in cameras, light meters, CD and DVD-ROM drives, TV remote controls, scanners, fax machines and copiers etc, and when integrated into operational amplifier circuits as infrared spectrum detectors for fibre optic communications, burglar alarm motion detection circuits and numerous imaging, laser scanning and positioning systems etc.

The Phototransistor

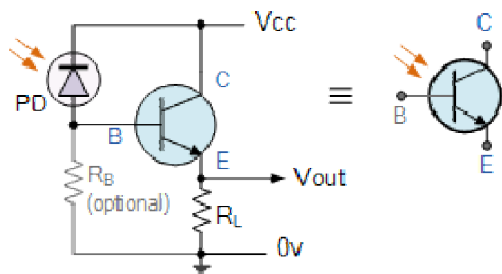

Photo-transistor

An alternative photo-junction device to the photodiode is the **Phototransistor** which is basically a photodiode with amplification. The Phototransistor light sensor has its collector-base PN-junction reverse biased exposing it to the radiant light source.

Phototransistors operate the same as the photodiode except that they can provide current gain and are much more sensitive than the photodiode with currents are 50 to 100 times greater than that of the standard photodiode and any normal transistor can be easily converted into a phototransistor light sensor by connecting a photodiode between the collector and base.

Phototransistors consist mainly of a bipolar [NPN Transistor](#) with its large base region electrically unconnected, although some phototransistors allow a base connection to control the sensitivity, and which uses photons of light to generate a base current which in turn causes a collector to emitter current to flow. Most phototransistors are NPN types whose outer casing is either transparent or has a clear lens to focus the light onto the base junction for increased sensitivity.

Photo-transistor Construction and Characteristics

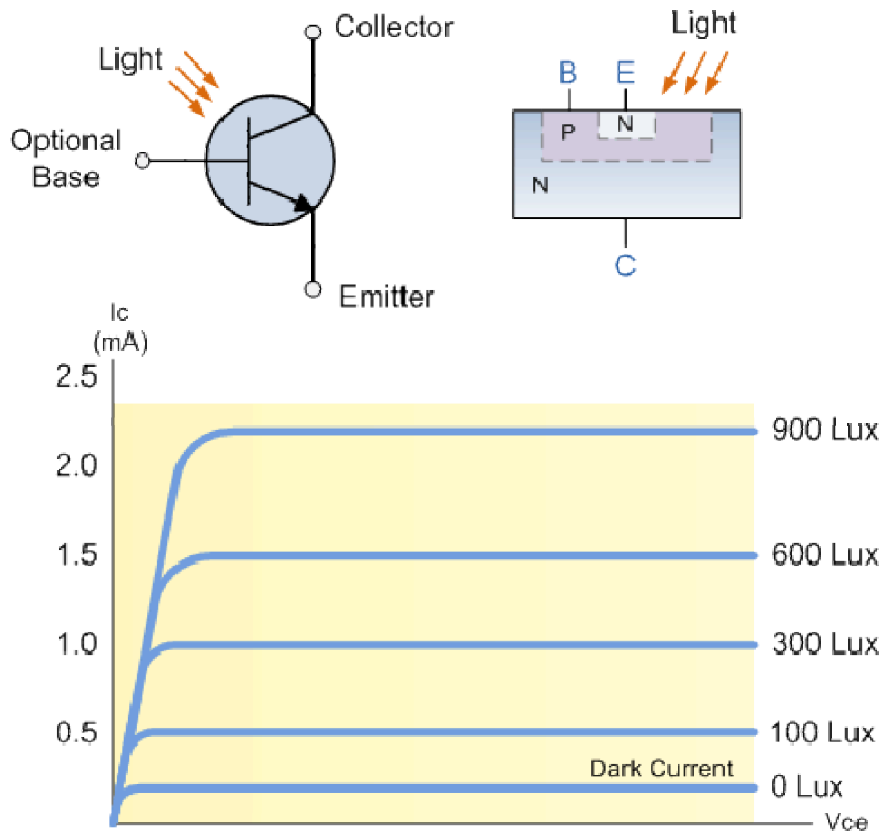

In the NPN transistor the collector is biased positively with respect to the emitter so that the base/collector junction is reverse biased. therefore, with no light on the junction normal leakage or dark current flows which is very small. When light falls on the base more electron/hole pairs are formed in this region and the current produced by this action is amplified by the transistor.

Usually the sensitivity of a phototransistor is a function of the DC current gain of the transistor. Therefore, the overall sensitivity is a function of collector current and can be controlled by connecting a resistance between the base and the emitter but for very high sensitivity optocoupler type applications, Darlington phototransistors are generally used.

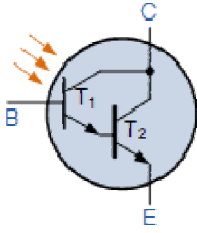

Photo-darlington

Photo darlington transistors use a second bipolar NPN transistor to provide additional amplification or when higher sensitivity of a photodetector is required due to low light levels or selective sensitivity, but its response is slower than that of an ordinary NPN phototransistor.

Photo darlington devices consist of a normal phototransistor whose emitter output is coupled to the base of a larger bipolar NPN transistor. Because a darlington transistor configuration gives a current gain equal to a product of the current gains of two individual transistors, a photo darlington device produces a very sensitive detector.

Typical applications of **Phototransistors** light sensors are in opto-isolators, slotted opto switches, light beam sensors, fibre optics and TV type remote controls, etc. Infrared filters are sometimes required when detecting visible light.

Another type of photo-junction semiconductor light sensor worth a mention is the **Photo-thyristor**. This is a light activated thyristor or **Silicon Controlled Rectifier, SCR** that can be used as a light activated switch in AC applications. However their sensitivity is usually very low compared to equivalent photodiodes or phototransistors.

To help increase their sensitivity to light, photo-thyristors are made thinner around the gate junction. The downside to this process is that it limits the amount of anode current that they can switch. Then for higher current AC applications they are used as pilot devices in opto-couplers to switch larger more conventional thyristors.

CURRENT TRANSDUCERS

A **current transducer** is a device that detects electrical current (AC or DC) in a wire, and generates a signal proportional to it. The generated signal could be analog voltage or current or even digital output. It can be then utilized to display the measured current in an ammeter or can be stored for further analysis in a data acquisition system or can be utilized for control purpose.

The sensed current and the output signal can be:

- AC current input,

- analog output, which duplicates the wave shape of the sensed current
- BIPOLAR output, which duplicates the wave shape of the sensed current
- unipolar output, which is proportional to the average or RMS value of the sensed current
- DC current input,
 - unipolar, with a unipolar output, which duplicates the wave shape of the sensed current
 - digital output, which switches when the sensed current exceeds a certain threshold

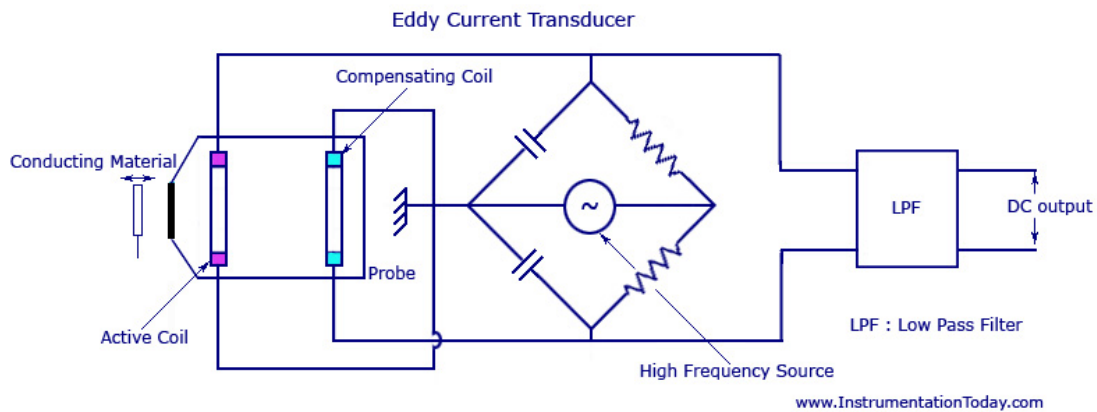

CHAPTER 7

AF SINE AND SQUARE WAVE GENERATOR

The signal generator will provide a variety of waveforms for testing electronic circuits, usually at low powers. The term oscillator will be used to describe an instrument that will only output a sine waveform. The term generator will be generalized into an instrument which is capable of providing other shapes of waveforms such as triangular and square waves.

There are various kinds of signal generators, however the operation of it is decided based on the following classes of information.

1. The frequency spectrum handled by the instrument should be known.
2. The region for which a stable frequency output can be provided should be known.
3. The output amplitude should be controllable with relatively low distortion.
4. The output signals should be distortion free at the matched impedance.

There are several categories of signal generators that span a wide frequency range. The two basic categories are the AF signal generators and the RF signal generators. The Table 1 provides continuous frequency ranges and the corresponding class of signal generators that cover it. Although various distinct categories of signal sources will be presented, many instruments have characteristics and ranges that transcend several categories.

BLOCK DIAGRAM OF AF SINE AND SQUARE WAVE GENERATOR

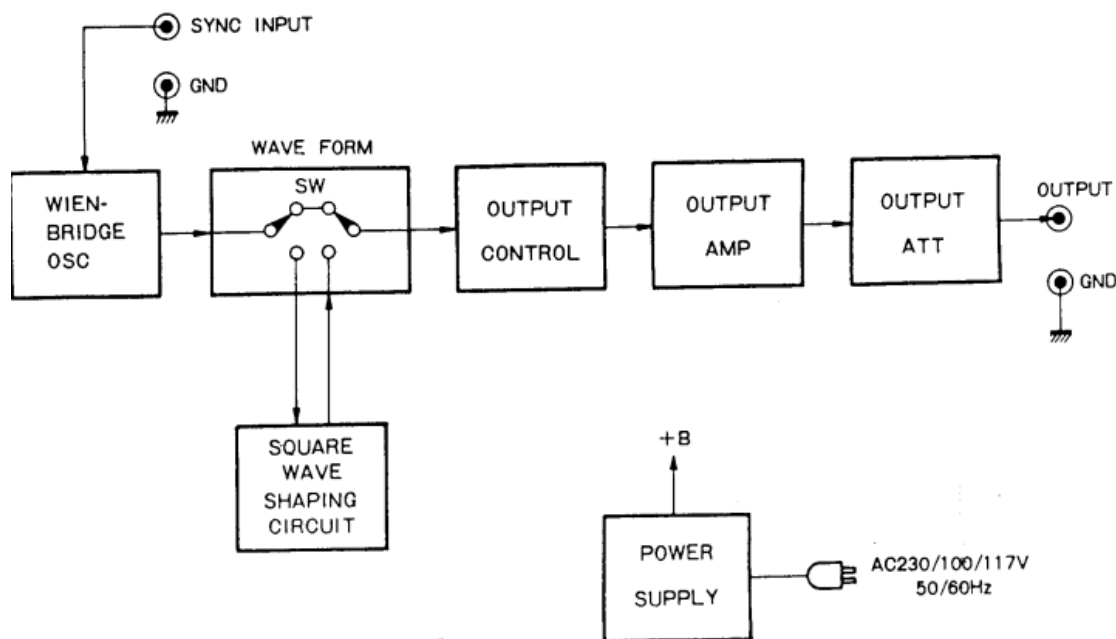

SUMMARY

When reading the following descriptions, please refer to the circuit diagram at end of this manual.

The sine wave signal generated by the Wien bridge oscillator circuit is fed through the WAVE FORM selector switch, set at the \sim position, to the OUTPUT control, by means of which it is adjusted to any desired voltage.

If the WAVE FORM selector switch is in the \square position, the sine wave signal output is fed from the switch to a square wave shaping circuit, where it is shaped into the square wave.

The square wave output signal from the square wave shaping circuit is then fed to the OUTPUT control, by means of which it is adjusted to any desired voltage in the same manner as for the sine wave signal.

The adjusted signal voltage is applied to the output circuit, where its impedance is appropriately converted, and then delivered through an output attenuator to the output terminal. This terminal provides an output impedance of approximately, 600 ohms, while the attenuator provides attenuation steps of 0dB, 20dB and 40dB.

WIEN BRIDGE OSCILLATOR CIRCUIT

The Wien bridge oscillator circuit elements consist of the resistance elements (FREQ RANGE), which may be switched over 4 ranges, and a variable capacitor (FREQUENCY dial). Each of the 4 selected ranges has a 10 to 1 adjustable frequency range to provide continuous overlapping coverage of the entire frequency range from 20Hz to 200kHz.

The amplifier circuit for the oscillator circuit is a high input impedance circuit employing an FET (Q1). Transistors Q2 and Q3 serve as the 2nd and 3rd amplifiers, while transistors Q4 and Q5 form a complementary output circuit.

Part of the output voltage is fed back with positive polarity through variable resistor VR1 to the oscillator elements of the Wien bridge to sustain the oscillation.

Another part of the output voltage is fed back with negative polarity through resistor R6 to the emitter of transistor Q2 to minimize waveform distortion.

The lamp inserted in the above-mentioned negative feedback loop stabilizes the amplitude of feedback voltage with its non-linear characteristic.

SQUARE WAVE SHAPING CIRCUIT

The square wave shaping circuit is essentially a Schmitt circuit consisting of transistors Q6 and Q7, which shapes the sine wave signal from the oscillator circuit into the proper square wave.

When there is no signal input, transistors Q6 and Q7 remain OFF and ON respectively in the Schmitt circuit. If a signal is applied to the input of this circuit, transistors Q6 and Q7 invert their operating conditions at the input signal rate, and generate a square wave at the output of the shaping circuit.

The symmetry of this circuit is factory adjusted to the proper value by means of variable resistor VR2.

OUTPUT CIRCUIT

The output circuit is essentially an impedance converter formed into a complementary output circuit comprised of transistors Q8 and Q9 with low output impedance. Operating with resistor R33 inserted in series, it provides 600 ohms output.

OUTPUT ATTENUATOR

When placed in the 0dB position, the OUTPUT ATTENUATOR allows the output signal to pass directly to the OUTPUT terminal. The OUTPUT LEVEL control can be used to vary the output from zero to maximum (10V RMS for sine wave output, or 10V p-p for square wave output).

In the 20dB position, it allows the signal to pass through an inverted L-attenuator with an attenuation of 20dB (1/10); the maximum output available using the OUTPUT LEVEL control is reduced to one-tenth.

In the 40dB position, it allows the signal to pass through an inverted L-attenuator with an attenuation of 40dB (1/100); the maximum output available using the OUTPUT LEVEL control is reduced to one-hundredth.

POWER SUPPLY

The secondary voltage of Transformer T1 is rectified by voltage doubler silicon rectifier D1 and D2 and capacitors C19 and C20 into a DC voltage. This DC voltage is supplied through the smoothing circuit to all of the circuits as +B supply (48V).

FUNCTION GENERATOR

A decent function generator is one of the most important pieces of equipment any electronics tinkerer can have on his workbench. A function generator produces different wave forms of adjustable frequency. The common output wave forms are the sine, square, triangular and saw tooth waves. The frequency may be adjusted, from a fraction of a Hertz to a several 1KHz.

The various outputs of the generators can be made available at the same time. For example the generator can provide a square wave to test the linearity of an amplifier and simultaneously provide a saw-tooth to drive the horizontal deflection of the CRO to provide a visual display.

Capability of phase lock :

The function generator can be phase locked to an external source . One function generator can be used to phase lock a second function generator and two output signal can be displaced in phase by adjustable amount .In addition , the fundamental frequency of one generator can be phase locked to the harmonic of another generator, by adjusting the phase

and amplitude of the harmonic , almost any wave form can be generated by addition.

The function generator can also be phase locked to a frequency standard and all it's output wave forms will then have the same accuracy and stability as the standard source.

BLOCK DIAGRAM OF FUNCTION GENERATOR

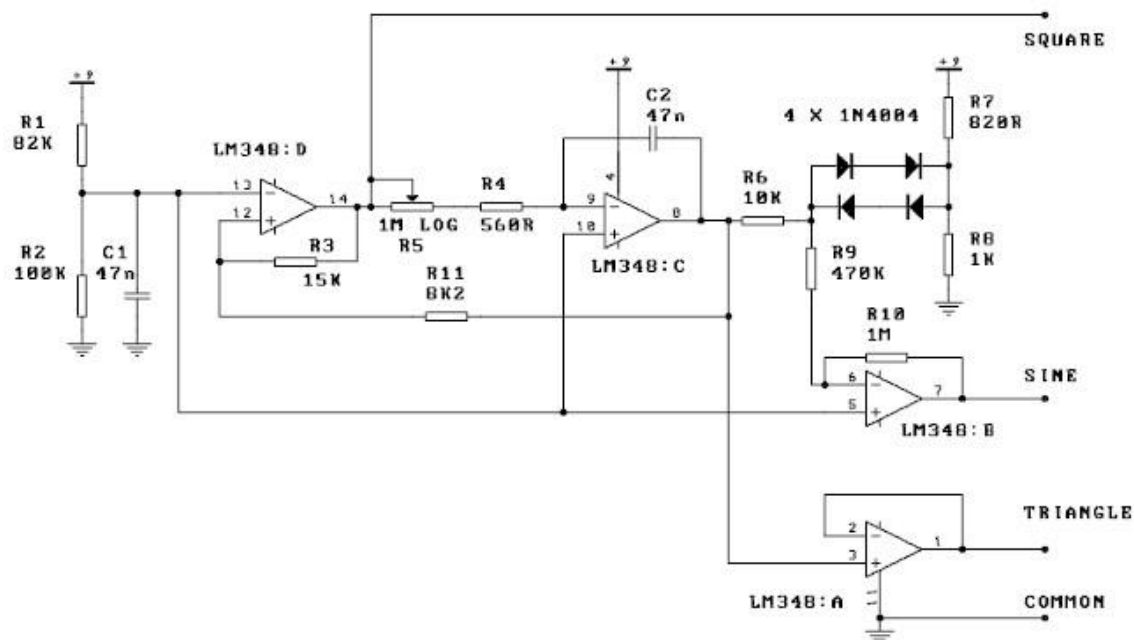

The frequency controlled voltage regulates two current sources . The upper current source supplies constant current to the integrator whose output voltage is increases linearly with time, according to the equation of output signal voltage . An increase or decrease in current increases or decreases the slope of the output voltage and hence controls the frequency .

The voltage comparator multi-vibrator changes states at a pre-determined maximum level of the integrator output voltage . This change cuts off the upper current supply and switches on the lower current supply.

WAVE ANALYZER

Introduction:

The analysis of electrical signals is used in many applications. The different instruments which are used for signal analysis are [wave analyzers](#), distortion analyzers, spectrum analyzers, audio analyzers and modulation analyzers.

All signal analysis instruments measure the basic frequency properties of a signal, but they use different techniques to do so. A spectrum analyzer sweeps the signal frequency band and displays a plot of amplitude versus frequency. It has an operating range of about 0.02 Hz-250 GHz. A wave analyzer is a [voltmeter](#) which can be accurately tuned to measure the amplitude of a single frequency, within a band of about 10 Hz – 40 MHz.

Distortion analyzers operate over a range of 5 Hz – 1 MHz and give a measure of the energy present in a signal outside a specified frequency band. They therefore tune out the fundamental signal and give an indication of the harmonics. An audio analyser is similar to a distortion analyser but can measure additional functions, such as noise. Modulation analysers tune to the required signal and recover the whole amplitude modulated (a.m.), frequency modulated (f.m.) or phase modulation (p.m.) envelope for display or analysis.

Wave Analyzers:

It is well known that any periodic waveform can be represented as the sum of a d.c. component and a series of sinusoidal harmonics. Analysis of a waveform consists of determination of the values of amplitude, frequency, and sometime phase angle of the harmonic components. Graphical and mathematical methods may be used for the purpose but these methods are quite laborious. The analysis of a complex waveform can be done by electrical means using a band pass filter network to single out the various harmonic components. Networks of these types pass a narrow band of frequency and provide a high degree of attenuation to all other frequencies.

A wave analyzer, in fact, is an instrument designed to measure relative amplitudes of single frequency Components in a complex waveform. Basically, the instrument acts as a frequency selective voltmeter which is tuned to the frequency of one signal while rejecting all other signal components. The desired frequency is selected by a frequency calibrated dial to the point of maximum amplitude. The amplitude is indicated either by a suitable voltmeter or a CRO.

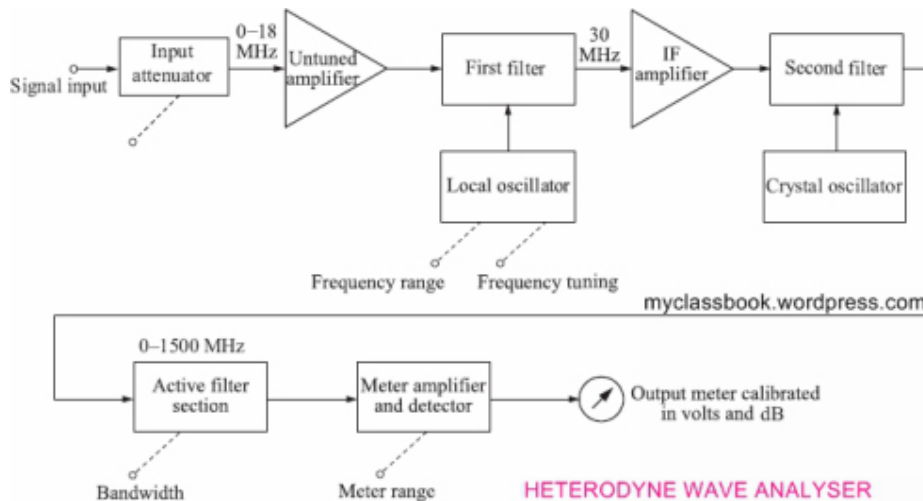

Heterodyne Wave Analyzer:

Introduction:

Analysis of the waveform means determination of the values of amplitude, frequency and sometime phase angle of the harmonic components.

A wave analyzer is an instrument designed to measure relative amplitude of signal frequency components in a complex waveform. basically a wave instruments acts as a frequency selective voltmeter which is tuned to the frequency of one signal while rejecting all other signal components.

It is well known that any periodic waveform can be represented as the sum of a d.c. component and a series of sinusoidal harmonics. Analysis of a waveform consists of determination of the values of amplitude, frequency, and sometime phase angle of the harmonic components. Graphical and mathematical methods may be used for the purpose but these methods are quite laborious. The analysis of a complex waveform can be done by electrical means using a band pass filter network to single out the various harmonic components. Networks of these types pass a narrow band of frequency and provide a high degree of attenuation to all other frequencies.

A wave analyzer, in fact, is an instrument designed to measure relative amplitudes of single frequency components in a complex waveform. Basically, the instrument acts as a frequency selective voltmeter which is used to the frequency of one signal while rejecting all other signal components. The desired frequency is selected by a frequency calibrated dial to the point of maximum amplitude. The amplitude is indicated either by a suitable voltmeter or CRO. This instrument is used in the MHz range. The input signal to be analyzed is heterodyned to a higher IF by an internal local oscillator. Tuning the local oscillator shifts various signal frequency components into the pass band of the IF amplifier. The output of the IF amplifier is rectified and is applied to the metering circuit. The instrument using the heterodyning principle is called *aheterodyning tuned voltmeter*.

The block schematic of the wave analyzer using the heterodyning principle is shown in fig. above.