

# **C.V. RAMAN POLYTECHNIC**

## **BHUBANESWAR**



### **LAB MANUAL**

**Year & Semester: 2<sup>ND</sup> Year, III Semester**

**Subject Code: PR-2**

**Subject Name: Circuit And Simulation Lab**

**DEPARTMENT  
OF  
ELECTRICAL ENGINEERING**

## **VISION OF DEPARTMENT**

To develop technically skilled Electrical Engineers contributing to sustainable development and technological advancement.

## **MISSION OF DEPARTMENT**

- To implement an effective teaching-learning process to develop skilled electrical engineers
- To provide technical and entrepreneurial skills to students and make them ready to be Placed in industry.
- Encouraging the students to pursue higher education and career-oriented courses.
- Developing ethics in students as well as responsibility towards the environment and The society

## **PROGRAM OUTCOMES (PO)**

<b>PO1</b>	Basic and discipline-specific knowledge
<b>PO2</b>	Problem analysis
<b>PO3</b>	Design/development of solutions
<b>PO4</b>	Engineering tools, experimentation, and testing
<b>PO5</b>	Engineering Practices for society, sustainability, and environment
<b>PO6</b>	Project Management
<b>PO7</b>	Lifelong Learning

## COURSE OBJECTIVE AND COURSE OUTCOMES

### PRACTICAL COURSE OBJECTIVE

- Verify the theorems using different components.
- Know the various types of filters.
- Simulate different circuits using P-Spice/MATLAB software.

### PRACTICAL COURSE OUTCOMES (CO)

Course Name	Statements
CO1	Understand and apply fundamental electrical circuit laws and theorems
CO2	Analyze and measure the behavior of series and parallel circuits
CO3	Evaluate power and power factor in electrical circuits
CO4	Design and analyze active filters
CO5	Interpret simulation results and compare them with theoretical predictions to validate circuit behavior.

## MAPPING OF LABORATORY EXPERIMENTS OF CIRCUIT AND SIMULATION LAB TO DEFINED CO

SL NO	EXPERIMENT NO	COURSE OUTCOME
1	4,5,6,7	C01
2	1,3	C02
3	2,8	C03
4	9,10	C04
5	3,4,5,6	C05

## MATRIX OF COs AND POs

Course Outcomes	Expected Mapping of COs with Programme Outcomes (POs) (1- Weak Correlation; 2- Medium correlation; 3- Strong Correlation)							Average CO
	PO1	PO2	PO3	PO4	PO5	PO6	PO7	
C01	3.0	2.0	1.0	2.0	-	-	2.0	2.0
C02	3.0	3.0	2.0	2.0	-	-	2.0	2.4
C03	3.0	3.0	2.0	3.0	1.0	-	2.0	2.3
C04	3.0	3.0	3.0	3.0	-	-	2.0	2.8
C05	3.0	3.0	2.0	3.0	1.0	1.0	2.0	2.1
Average PO	3.0	2.8	2.0	2.6	1.0	1.0	2.0	2.3 2.1

### **Program Specific Outcomes (PSOs):**

**PSO1:** Ability to apply electrical engineering knowledge, skills for testing, control & maintenance of electrical systems such as Machines, Power Systems, Drives & Automation.

**PSO2:** Ability to identify problems in the diversified areas of Electrical Engineering and determine the hardware or software solutions to support the Societal, Environmental & Industrial needs.

### **MATRIX OF COs AND PSOs**

<b>CO/PSO</b>	<b>PSO1</b>	<b>PSO2</b>	<b>Average CO</b>
<b>CO1</b>	<b>3.0</b>	<b>2.0</b>	<b>2.5</b>
<b>CO2</b>	<b>3.0</b>	<b>3.0</b>	<b>3</b>
<b>CO3</b>	<b>3.0</b>	<b>3.0</b>	<b>3</b>
<b>CO4</b>	<b>3.0</b>	<b>2.0</b>	<b>2.5</b>
<b>CO5</b>	<b>3.0</b>	<b>3.0</b>	<b>3</b>
<b>Average PSO</b>	<b>3.0</b>	<b>2.6</b>	

## LIST OF EXPERIMENTS

SL. NO.	NAME OF THE EXPERIMENT	PAGE NO.
1	To measurement of equivalent resistance of series and parallel circuit.	1 – 2
2	Measurement of power and power factor using series RLC load	3 – 4
3	To verify the KCL & KVL	5 – 7
4	Study and verification of the Superposition Theorem.	8 – 10
5	To study and verification of Thevenin 's theorem.	11 – 12
6	To study and verification of the Norton's theorem	13 – 15
7	Study and verification of the maximum power transfer theorem.	16 – 18
8	To study of Resonance in series RLC circuit and to find its resonance frequency.	19 – 20
9	Study of Active Low Pass Filter and to Evaluate cut off frequency, pass band gain	21 – 25
10	Study of Active High Pass Filter and to Evaluate cut off frequency, pass band gain	26 – 32

## EXPERIMENT NO :1

### AIM OF THE EXPERIMENT:

To measurement of equivalent resistance of series and parallel circuit.

### EQUIPMENT REQUIRED:

SL .NO	NAME OF THE EQUIPMENT	SPACIFICATION	QUANTITY
1	Resistors	100 ohm, 220 ohm, 100ohm, 320ohm, 220ohm, 200ohm,	7
2	Multi meter	Digital	1
3	Power supply	5v	1

### THEORY: -

#### FOR SERIES CIRCUIT: -

In electrical circuit is in series connected the current flowing through the conductor is constant but voltage is not constant and the resistance can be calculated by.

$$R_{eq} = R_1 + R_2 + R_3 + \dots + R_n$$

#### FOR PARALLEL CIRCUIT: -

In electrical series is in parallel connected the current flowing through the conductor is not constant but voltage is remain constant and the resistance can be calculated by.

$$1/R_{eq} = 1/R_1 + 1/R_2 + 1/R_3 + 1/R_4 + \dots + 1/R_n$$

### CIRCUIT DIAGRAM:

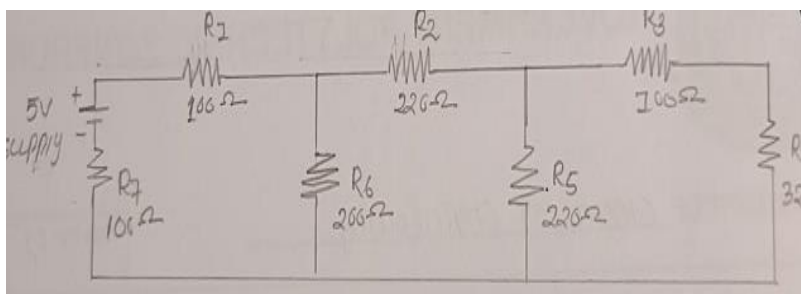

**PROCEDURE:**

- Make the connections according to the circuit diagram without switch on the supply switch.
- Connect ammeter in series and voltmeter in parallel with the circuit to take the supply voltage reading and the total current draw from the supply.
- Carefully check the (+ve) and (-ve) terminals of battery voltmeter, ammeter and connection as per the circuit diagram.
- Record the ammeter and voltmeter reading by switches the power supply of the kit and calculate the Reg of the circuit by using formula  $R_{eq} = V_s/I$ .
- Also we can measure the Req. by using multi meter.

**CALCULATION:**

$R_3$  &  $R_4$  both are series connection

$$R_x = R_3 + R_4 = 100 + 320 = 420 \text{ ohm}$$

$R_5$  &  $R_x$  are in parallel connection

$$R_4 = 1/R_5 + 1/R_x = R_5 R_x / R_5 + R_x = 220 \times 420 / 220 + 420 = 144.37 \text{ ohm}$$

$R_2$  &  $R_4$  are series connection

$$R_2 = R_2 + R_y = 220 + 114.37 = 364.37 \text{ ohm}$$

$R_6$  &  $R_2$  are parallel connection

$$200 \times 364 / 200 + 364.37 = 129.12 \text{ ohm}$$

$$R_{eq} = 100 + 100 + 129.12 = 329.12 \text{ ohm}$$

**TABULATION:**

SL .NO	V(v)	$R_{eq}$ (ohm)	I(Amp)
1	5	329	0.015

**CONCLUSION:**

From the above experiment we have strolled & verified that the practical value is approximately same to the theoretical value in both series in both series and parallel circuit.



## EXPERIMENT NO:2

### AIM OF THE EXPERIMENT:

Measurement of power and power factor using series RLC load

### APPARATUS REQUIRED:

Sl. No.	NAME OF EQUIPMENT	SPECIFICATION	QUANTITY
01	Variable resistor	0 – 100 ohm	1
02	Inductor	40w, 250v	1
03	Capacitor	2.5 micro fared	1
04	Voltmeter	0 -300V	1
05	Ammeter	0-5A	1
06	Single phase wattmeter	250v ,1KW	1
07	Connecting wire	2mm	As per required

### THEORY:

A series RLC circuit is one resistor, inductor and capacitor are connected in series across a voltage supply. The resulting circuit is called series RLC circuit.

### CIRCUIT DIAGRAM:

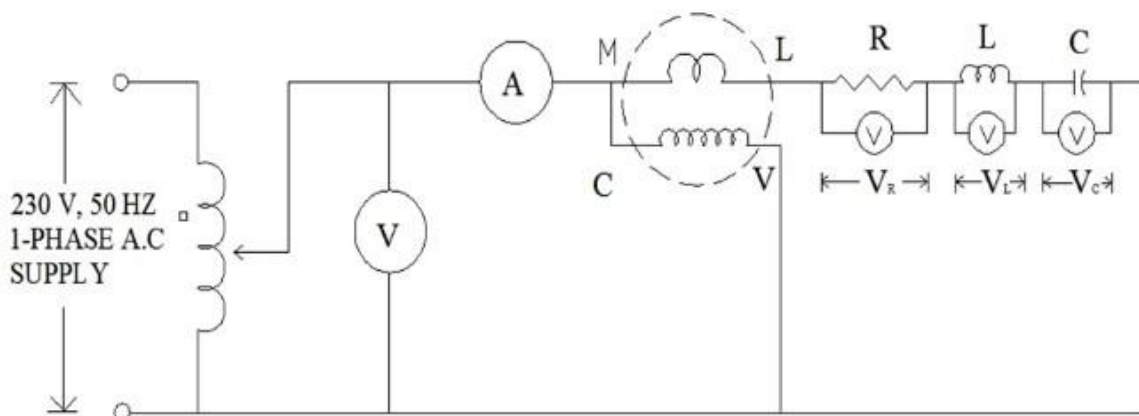

### **PROCEDURE:**

- We should take all the tools and instrument for this experiment.
- Connect the circuit as per the circuit diagram.
- Then switch on the supply.
- Take reading of wattmeter ,voltage and ammeter.

### **CALCULATION :**

$$\text{COS} = P/VI$$

#### **CASE 1-**

$$V= 160V, I= 0.30AMP, P = 17WATT$$

$$\text{COS} = 17/160*0.30 = 0.35$$

#### **CASE 2-**

$$\text{COS} = 19/180*0.35 =0.30$$

#### **CASE 3-**

$$\text{COS} = 25/200*0.38 =0.32$$

#### **CASE 4-**

$$\text{COS} = 30/220*0.4 =0.34$$

### **CONCLUSION**

From the above experiment we learnt about the measurement of power and power factor using series RLC load.

### EXPERIMENT NO:03

**AIM OF THE EXPERIMENT:** To verify the KCL & KVL

**EQUIPMENT REQUIRED:**

Sl. No.	Name of the equipment	Specification	Quantity
1	KCL and KVL Trainer kit	-	1
2	Patch cord	2mm patch cord	As per required
3	Power supply	12 DC Supply	1
4	Multi meter	Digital type	1

**THEORY:**

- KCL states that the algebraic sum of all the current meeting at a point or a junction is equal to zero.
- It can be stated that incoming current at a point will be equal to the total outgoing current.
- KVL states the algebraic sum of emf or product of current and resistance in a closed loop is equal to zero.

**CIRCUIT DIAGRAM:**

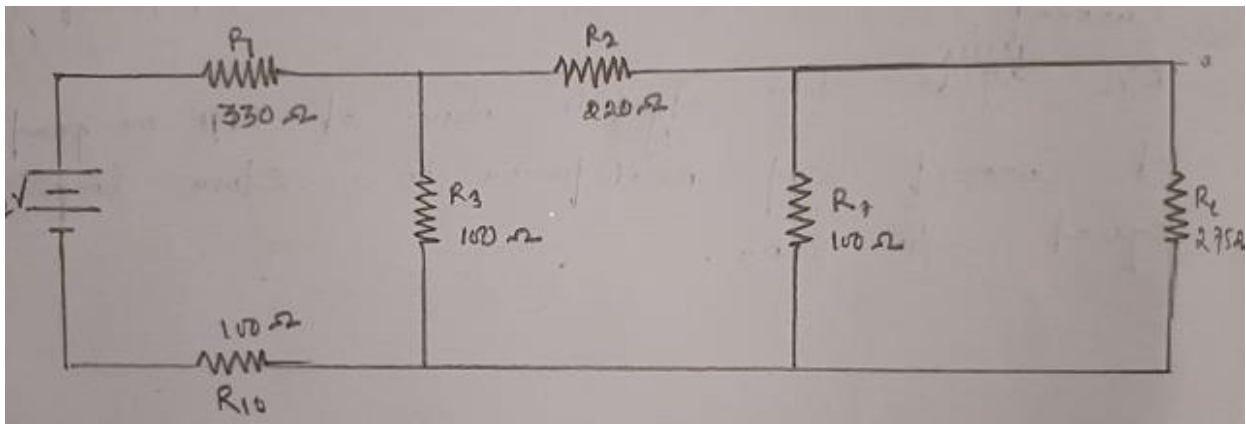

## PROCEDURE:

- Connect inbuilt +DC power supply 12V to the indicated position on train circuit.
- Connect 2mm patch cord between test point 1 & 2, 3 &4, 5&6, 7 &8 , 9 &10 ,11 &12, 13 &14, 15 &16.
- Switch on the power supply.
- To test KVL in loop ABCD.
- Measure current in flowing through resistor of 330 ohm with the help of inbuilt ammeter by replacing 2mm patch card between test point 1 &2 with ammeter.
- Reconnect patch cord between test point 1&2 .
- Measure I1 flowing through resistor 100 ohm with the help of inbuilt ammeter by replacing 2mm patch cord between test point 7 & 8 with ammeter .
- Reconnect patch cord between test point 7 &8.
- Measure current flowing through resistor of 100 ohm with the help of inbuilt ammeter by replacing 2mm patch cord between test point 15 & 16 with ammeter.
- Reconnect patch cord between test input 15 &16.
- Calculate different IR drop in the selected loop (check that the high of IR drop should be given offer considering direction on current ).
- Measure the sum of IR drop with their sign.
- Equal the sum of all IR drop with their sign and sum of the source voltage of that particular loop.
- In case of no voltage source in loop take the sum of all voltage sources equal to zero.
- Repeat above procedure for loop BCHJ , CDGH and DEFG.

## CALCULATION

Step-1(consider +5v)

$$R_{eq} = [ \{ \{ (R_4 + R_2) \} \parallel R_6 \} + R_2 ] \parallel R_6 \parallel R_1 + R_7$$

We know that ,  $V = IR$

$$\text{Therefore, } I = \frac{V}{R} = \frac{5}{R_{eq}}$$

Step-2(consider +12v)

$$R_{eq} = [ \{ \{ (R_7 + R_1) \} \parallel R_6 \} + R_2 ] \parallel R_5 \parallel R_4 + R_3$$

$$\text{Therefore, } I = \frac{V}{R} = \frac{12}{R_{eq}}$$

$$I = I_1 + I_2 + I_3 + I_4$$

$$V = I_1 R_1 + I_2 R_2 + I_3 R_3 + I_4 R_4$$

**OBSERVATION TABLE: For KCL**

SL.NO	RESISTOR(ohm)	CURRENT (Amp)
1	R1	I1
2	R2	I2
3	R3	I3
4	R4	I4
5	R5	I5
6	R6	I6
7	R7	I7
8	R8	I8
9	R9	I9
10	R10	I10

**OBSERVATION TABLE: For KVL**

SL. NO.	RESISTER(ohm)	VOLTAGE DROP(IR)(volt)
1	R1	V1
2	R2	V2
3	R3	V3
4	R4	V4
5	R5	V5
6	R6	V6
7	R7	V7
8	R8	V8
9	R9	V9
10	R10	V10

**CONCLUSION:**

From the above experiment we observed that the sum current at a node is equal to zero and the sum emf and voltage drop in a close loop is equal to zero.

## EXPERIMENT NO:04

**AIM OF THE EXPERIMENT:** Study and verification of the Superposition Theorem.

**EQUIPMENT REQUIRED:**

SL NO.	Name of the equipments	Specification	Quantity
01	Digital multimeter	-	As per Required
02	2mm patch cords	-	As per Required
03	Power supply	12v,15v,500ma	As per Required
04	Patch cord	-	As per Required

**THEORY:**

- The total current in any part of a linear circuit equals the algebraic sum of the currents produced by each source separately.
- The superposition theorem is an important concept in circuit analysis. It allows you to determine a voltage across a component or a branch current by calculating the effect of each source individually, and then algebraically adding each contribution.
- Superposition may be considered for circuit analysis when there are two or more energy source. The sources are either voltage or current sources.

The circuit is not too complex.
- There are seven steps used in applying the superposition theorem to a circuit.
  1. Select one energy source.
  2. Remove all other sources by
    - Replacing voltage source with a short while retaining any internal source resistance.
    - Replacing current source with an open while retaining any internal resistance.
  3. Calculate the desired voltage drops or branch currents paying attention to the voltage polarities and current directions.
- 4. Repeat steps 1 through 3 for each other source individually.
- 5. Algebraically add the contributions of each voltage or current.

### CIRCUIT DIAGRAM:

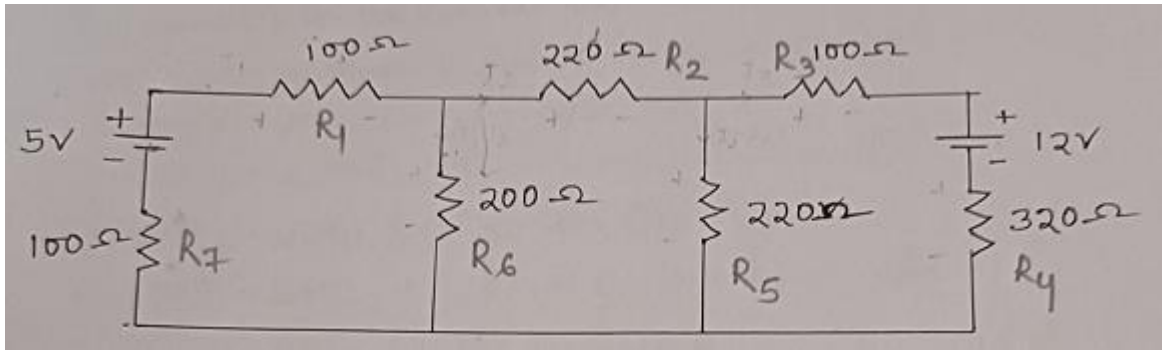

### PROCEDURE:

- Connect 5v dc power supply and ground using patch cords to their indicated positions of superposition circuit as shown in circuit diagram.
- Similarly connect 12v dc supply and ground to their indicated positions of superposition circuit.
- Connect 2mm patch cord to connect R5.
- Connect on board ammeter series with R6 to measure current through it.
- Now remove one of the supply 5v from the circuit.
- Connect a 2mm patch cord between terminal 5v and ground.
- Measure the value of current flowing through resistance 200ohm in presence of single voltage of 12v.
- Now remove other supply 12v from the circuit and connect the other 5v dc supply their indicated position.
- Connect a 2mm patch card between terminals 12v and ground.
- Measure the value of current flowing through resistance 200ohm in presence of single voltage source of 5v.
- Compare the amount of current flowing through in presence of both of the source with the sum of current flowing in case of individual source. These currents must follow the relation.  $I=I'+I''$
- Repeat above procedure for other branches of circuit.

**CALCULATION:**

in the circuit we calculate the 'I' [ $I' = I_1 - I_2$ ]

We want to know  $I_1$  and  $I_2$  there are in equation

$$5 - 100I_1 - 200(I_1 - I_2) - 100I_1 = 0$$

$$400I_1 - 200I_2 = 5 \dots\dots\dots (1)$$

$$-200I_2 - 220(I_2 - I_3) - 200(I_2 - I_1) = 0$$

$$200I_1 - 640I_2 + 220I_3 = 0 \dots\dots\dots (2)$$

$$-100I_3 - 320I_3 - 220(I_3 - I_2) = 0$$

$$220I_2 - 640I_3 = 0 \dots\dots\dots (3)$$

Solve the 3 equation

$$I_1 = 0.01519179004 = 15.19179004 * 10^{-3}$$

**CONCLUSION:**

From there above experiment we study and absurd that different branch current of using super position theorem



## EXPERIMENT NO:05

**AIM OF THE EXPERIMEN:** To study and verification of Thevenin 's theorem.

**EQUIPMENTS REQUIRED:**

SL No.	Name of the Equipment	Specification	Quantity
01	Thevenin's theorem kit	-	1
02	2mm Patch cords	2mm	As per required
03	Digital multimeter	-	1
04	Power supply	+12v,+15v, DC	-

**THEORY:**

This theorem possibly the most extensively used network theorem. It is used when it is desired to determine the current through or voltage across any one element in a network without going through the rigorous method of solving a set of network equation.

Any two terminal bilateral linear DC circuit can be replaced by an equivalent circuit consisting of a voltage source and a series resistor.

**CIRCUIT DIAGRAM:**

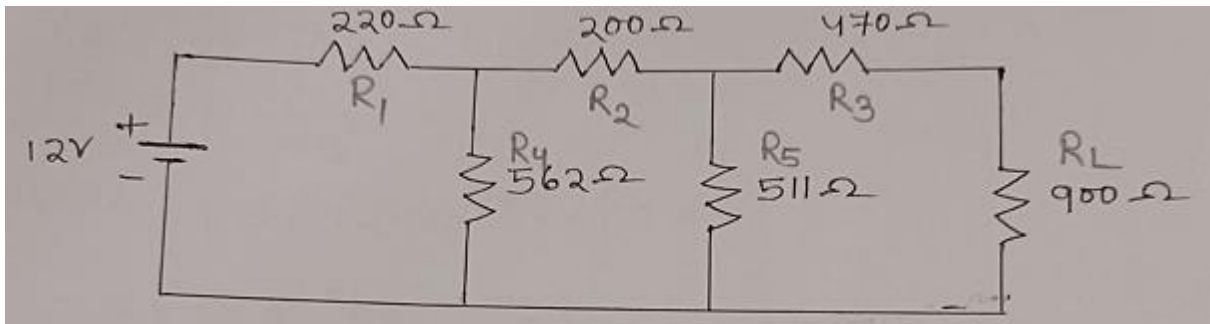

**PROCEDURE:**

- Connect +12v DC power supply and ground using patch cords to terminal +vcc and GND as shown in the circuit diagram on thevenin's theorem kit .
- Measure voltage between terminals 1 and 3 or across load resistor 900ohm. For this connect terminal 1 to the terminal of DC voltmeter and 3 to negative terminal. It is the required value of Thevenin's equivalent voltage  $V_{th}$  .
- Disconnect the patch cord between terminal +Vcc to +12 and Ground.
- Short circuit all the voltage source used in the circuit .
- Measure Thevenin's equivalent resistance between terminal 1 and 3 using multimeter.
- Compare theoretical and practical value of thevenin's equivalent resistance and Thevenin's equivalent resistance and Thevenin's voltage .
- Set the value of load resistance of given circuit connect +12v DC to the thevenin's equivalent circuit and observe the value of load current  $I_l$  by using on board Ammeter.

Result:

Theoretical value of Thevenin's equivalent voltage = \_\_\_\_\_ v

Practical value of Thevenin's equivalent voltage = \_\_\_\_\_ v

Theoretical value of Thevenin's equivalent Resistance = \_\_\_\_\_  $\Omega$

Practical value of Thevenin's equivalent Resistance = \_\_\_\_\_  $\Omega$

Theoretical value of current flowing through load = \_\_\_\_\_ amp

Practical value of current flowing through = \_\_\_\_\_ amp

**CONCLUSION:**

From the above experiment we know that how to verify Thevenin's theorem.

## EXPERIMENT:06

**AIM OF THE EXPERIMENT:** To study and verification of the Norton's theorem

**EQUIPMENT REQUIRED:**

Si no.	Name of the equipment	Specification	Quantity
1	Digital multi meter	-	-
2	2 mm patch cord	-	As per required
3	Power supply	-	As per required
4	Mains cord	-	-

**THEORY:**

Norton's theorem is converse of thevenin's theorem it consists of equivalent current source instead of equivalent voltage source as we do in thevenin's theorem .however in final stage, i.e , in the Norton's equivalent circuit, the current generator is placed in parallel to the internal resistance unlike to that in thevenin's theorem where equivalent voltage source was placed in series with internal resistance

**STATEMENT OF NORTON'S THEOREM:**

A linear active network consist of independent and dependent voltage and current source and linear bilateral network element can be replaced by an equivalent circuit. consisting of current source in parallel with a resistance , the current source being the short circuited current across the load terminal and the resistance being the internal resistance of the source network looking through open circuited load terminals .

**CIRCUIT DIAGRAM:**

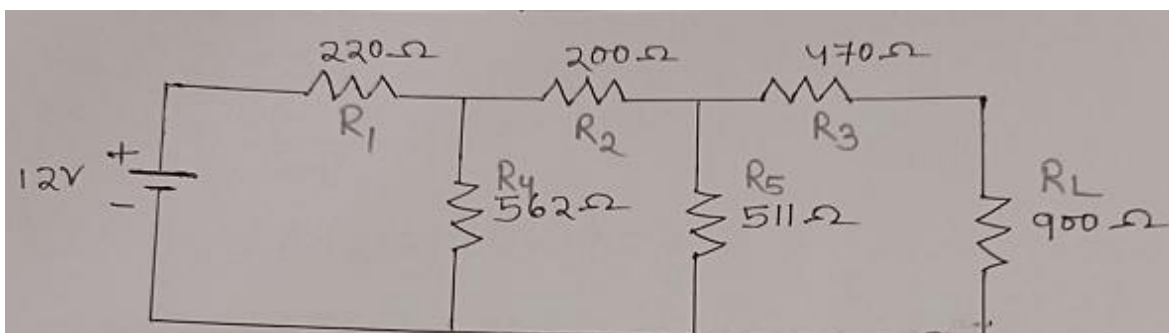

**PROCEDURE:**

- Connect 5 volt dc power supply and ground using patch cords to terminals +Vcc and GND as shown in Norton's theorem kit .
- Measure current between terminals 1 & 3, for this connect terminal 1 & 3 to +Ve terminals of the ammeter respectively. It the required value of Norton current  $I_N$ .
- Measure theoretical value of Norton's current  $I_N$  and Norton's equivalent resistance  $R_N$ .
- Connect terminals +Vcc and GND so as to replace source by its internal resistance.
- Measure resistance between terminal 1&3 using multi meter.
- It is the required value of Norton's equivalent resistance  $R_N$ .
- Connect a 2mm patch cord between terminals +Vcc and +5v and GND1 to GND terminal.
- Connect an ammeter terminal between 1 and 2 to measure load current  $I_L$ , following through load resistance.
- Set the value of load resistance of given circuit and load of equivalent circuit same & equal.
- To compare the given circuit with its Norton's equivalent circuit.
- Connect an ammeter between terminal 4&5 and examination the value. This current is same as  $I_N$  of Norton's equivalent circuit.

**CALCULATION:**

$$5 - 220I_1 - 562(I_1 - I_2) = 0$$

$$\Rightarrow -220I_1 - 562I_2 + 562I_2 = -5$$

$$\Rightarrow 782I_1 - 562I_2 = 5 \text{ _____ (1)}$$

$$-200I_2 - 511(I_2 - I_3) - 562(I_2 - I_1) = 0$$

$$\Rightarrow 562I_1 - 1273I_2 + 511I_3 = 0 \text{ _____ (2)}$$

$$-470I_3 - 511(I_3 - I_2) = 0$$

$$\Rightarrow 511I_2 - 981I_3 = 0 \text{ _____ (3)}$$

There Are 3 Equation

solve :-

$$I_1 = 0.010677 \text{ Amp}$$

$$I_2 = 5.959823 \text{ mAmp}$$

$$I_3 = 3.104454 \text{ mAmp} \quad [I_3 = I_{sc}]$$

**CONCLUSION:**

From the above experiment we verify that and observed the Thevenin's theorem.

## EXPERIMENT NO:7

**AIM OF THE EXPERIMENT:** Study and verification of the maximum power transfer theorem.

### EQUIPMENT REQUIRED:

Sl. No	Name of the equipment	specification	Quantity
1	Digital multi meter	-	-
2	2mm patch cord	-	As per required
3	Power Supply	+12V,+5V,500 MA	As per required
4	Mains Cord	-	-

### THEORY:

The maximum power transfer theorem states that when the load resistance is equal to the Source's internal resistance. Maximum power will be developed in the load. Since most of the load voltage dc power supplies have a very low internal resistance (10 ohm or less), great difficulty would result in trying to affect this conditions under actual laboratory experiments.

### CIRCUIT DIAGRAM:

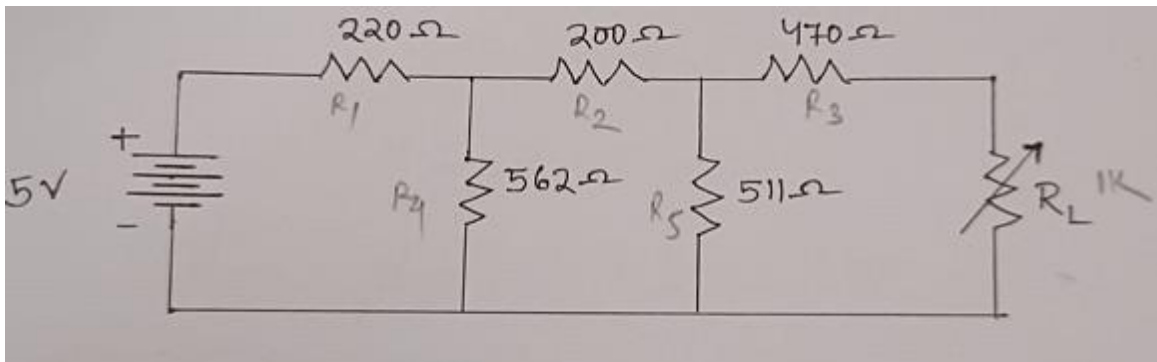

### PROCEDURE:

- To perform the maximum power transfer theorem states that when the load resistance is equal to the sources equivalent circuit with +5V ( Vcc ) dc supply as shown in figure.
- Now set the value of load resistance  $R_L$  of Thevenin's equivalent circuit at some lower value 400ohm. For this connect multi meter between terminals 12 and 13 and set the resistance.

- Now remove multi meter and connect +5V supply to terminal +5V and ground to ground as shown on figure.
- Connect the on board DC ammeter between terminals 11 and 12 for this connect terminal 11 to +ve terminal of ammeter and 12 to its –ve terminal.
- Observe the reading of Dc ammeter, this will give the load current  $I_L$ .
- Determine the value of  $I_L^2 * R_L$ , the power dissipated for  $R_L$  value of load resistance.
- Record the value of load current  $I_L$  with respect to load resistor  $R_L$ , in power dissipated  $P_L$  in an observation table.
- Now repeat same steps for different value or resistance like 500ohm,600ohm, 800ohm.

NOTE :- Set the value of  $R_L$  very precisely using provided potentiometer for getting accurate results.

SL. NO.	Load Resistance $R_L$	Load Current $I_L$	Power Dissipated $P_L$
01	400ohm		
02	500ohm		
03	600ohm		
04	680ohm		
05	750ohm		
06	800ohm		

Observe for what value of resistance the maximum power is transferred. This resistance must be equal to the Thevenin resistance or internal resistance of the circuit.

**CALCULATION:**

$$\begin{aligned}
 V_{TH} &=> R_{EQ}V = \left[ \frac{(200+511)}{562} \right] + 220 \\
 &= (711//562) + 220 \\
 &= 533.89 \Omega
 \end{aligned}$$

$$I = V / R_{EQ} V = 12/533.89 = 0.0224 \text{ Amp.}$$

$$I_1 = 0.0224 * 562 / 200 + 511 + 562 = 9.9198 * 10^{-3}$$

$$\text{So, } V_{TH} = 9.9198 * 10^{-3} * 511 = 5.06 \text{ V}$$

$$R_{TH} &=> \left[ \frac{(220//562) + 200}{511} \right] + 470$$

$$=> (358.1074169//511) + 470$$

$$=> 680.5526733 \Omega$$

$$P_L \text{ Max} = V_{TH}^2/4R_{TH} = (5.06)^2/4*680.5526733 = 9.40544 \text{ mA Wt.}$$

**RESULT:**

The sum of current flowing through branches in case of individual source is nearly equal to amount of current flowing through the same branch in case of both of the sources.

**CONCLUSION:**

From the above experiment we conclude that for  $R_L = R_{TH}$  ,We get the maximum power transferred to the load end.



## EXPERIMENT NO:08

**AIM OF THE EXPERIMENT:** To study of Resonance in series RLC circuit and to find its resonance frequency.

### **EQUIPMENT REQUIRED:**

SL.NO.	Name of the equipment	Quantity
1	RLC resonance trainer kit	1
2	Oscilloscope	1

### **THEORY:**

We know that Resistor (R), Inductor (L), and Capacitor (C) are the passive elements. We can connect these passive elements in several ways. For the time being, let us consider the basic connections. These are series connections and parallel connections.

If we connect an AC source with variable frequency to the RLC network/ circuit combination, then at one frequency, the energy stored in both inductor and capacitor will be equal, or the net energy stored in the circuit will be zero. This frequency is known as resonant frequency, and we can say that the circuit is at resonance. In the RLC circuit the current at resonance is  $I = VR$ .

### **CIRCUIT DIAGRAM:**

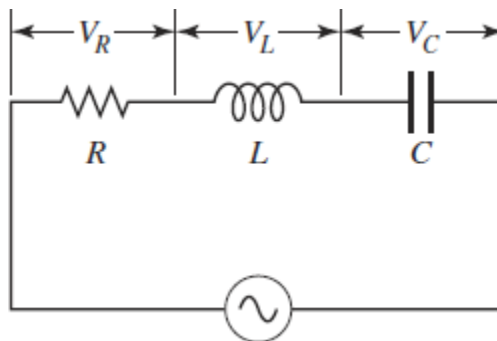

### **PROCEDURE:**

- Connect terminal A and B so that inductor  $L_1$  and capacitor  $C_1$  will be in series.
- Now connect generator output to this series combination, for this connect TP9 and TP10 to  $V_{in}$  and TP4 (Ground) respectively.
- To observe the output of the circuit, connect TP1 and TP4 to +ve and -ve terminal of display.
- Switch on the power supply.

- Select 1KHz range from frequency range selector.
- Vary the frequency by variable frequency by variable frequency knob and observe the change in output voltage on display.
- Apply same process for other two frequency ranges and note the minimum voltage.
- Now connect the CRO across TP9 and TP10 and find the frequency for which the output voltage is minimum among these three ranges. This frequency will be the resonance frequency of this RLC circuit.
- Similarly select other combinations like L<sub>1</sub>-C<sub>2</sub>, L<sub>2</sub>-C<sub>1</sub>, L<sub>2</sub>-C<sub>2</sub> by connecting terminals A-D, C-B and C-D respectively one by one and apply same procedure to find the resonance frequency.
- Record your observations in the observation table.

**OBSERVATION TABLE :**

S. No.	Combination	Minimum output Voltage	Resonance Frequency
1	L1-C1		
2	L1-C2		
3	L2-C1		
4	L2-C2		

**RESULT :**

Theoretical value of resonant frequency  $f_r = \underline{\hspace{2cm}}$  Hz

**CONCLUSION:**

From the above experiment we observed the resonance condition in series RLC circu

## EXPERIMENT NO:09

**AIM OF THE EXPIMENT:** Study of Active Low Pass Filter and to Evaluate:

1. High cutoff frequency of Low Pass Filter
2. Pass band gain of Low Pass Filter
3. Plot the frequency response of Low Pass

**EQUIPMENT REQUIRED:**

SL.NO.	Name of the equipment	Quantity
1	Active filter trainer kit	1
2	Oscilloscope	1
3	Digital Multi meter	2

**THEORY:**

Active filters such as an active low pass filter, are filter circuits that use an operational amplifier (op-amp) as the their main amplifying device along with some resistors and capacitors to provide a filter like performance at low frequencies.

Basic first-order passive filter circuits, such as a low pass or a high pass filter can be constructed using just a single resistor in series with a non-polarized capacitor connected across a sinusoidal input signal. The main disadvantage of passive filters is that the amplitude of the output signal is less than that of the input signal, ie, the gain is never greater than unity and that the load impedance affects the filters characteristics.

With passive filter circuits containing multiple stages, this loss in signal amplitude called "Attenuation" can become quiet severe. One way of restoring or controlling this loss of signal is by using amplification through the use of **Active Filters**.

**CIRCUIT DIAGRAM :**

Circuit used to study Active Low Pass Filter shown

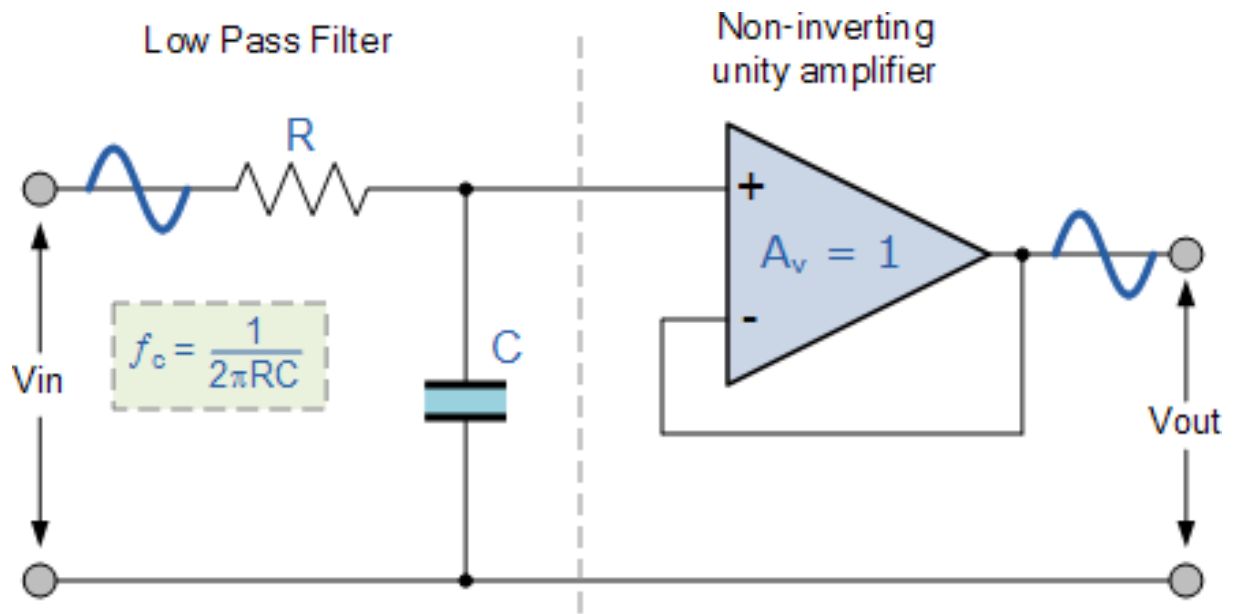

## **PROCEDURE :**

- Initially rotate potentiometers R1 and Rf in fully clockwise direction in order to make R1 = Rf = 10K, so that according to the formula given below

$$V_o = (1+R_f/R_1) V_{in}$$

The gain of the output will be twice of the input.

- The high cutoff frequency is given by the formula:

$$f_h = \frac{1}{2\pi RC}$$

- Connect an Ohmmeter between Vin of Low Pass Filter and TP6. Adjust resistance value at 1.59K by varying the potentiometer of 22K to set the high cutoff frequency (fh) at 10K.
- Connect +12V and –12V DC power supplies at their indicated position from Power Supply section.
- Connect all the ground test points using patch chords.
- Switch 'On' the Power Supply.
- Set the output of function generator at 2 volt, 500 Hz using Oscilloscope with sinusoidal waveform.
- Connect TP1 with Vin of Low Pass Filter to give a sinusoidal signal of amplitude 2Vpp of frequency 500Hz to Low Pass Filter.
- Observe output on Oscilloscope.
- Similarly you can give the triangular and square wave instead of sinusoidal wave, from the function generator section.
- As we know according to the formula, Output gain is directly proportional to the Rf and inversely proportional to the R1. So, we can adjust the gain of the output by increasing the value of Rf as well as by decreasing the value of R1.
- So, change the values of R1 and Rf and observe the change in output.
- Increase the frequency of input signal step by step and observe the effect on output Vout on Oscilloscope.
- Tabulate the values of Vout, gain, gain (db) at different values of input frequency shown in Observation Table.

**OBSERVATION TABLE:**

S. No.	Input frequency (Hz)	Vout	$ V_{out}/V_{in}  = \text{gain}$	Gain(db) = $20 \text{ Log }  V_{out}/V_{in} $
1	500			
2	1 K			
3	5 K			
4	10 K ( $f_H$ )			
5	15 K			
6	20 K			
7	30 K			

- Plot the frequency response of Low Pass Filter using the data obtained at different input frequencies.

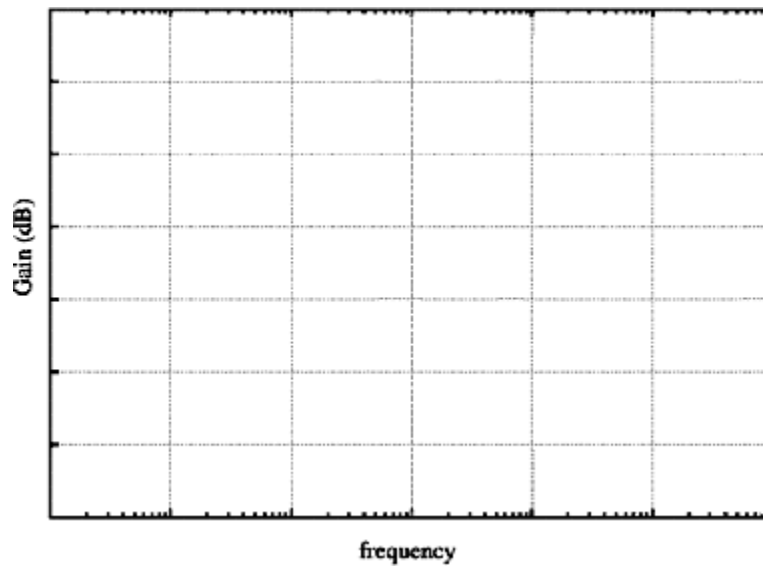

- As we know, according to the formula

$$V_{out} = (1 + R_f/R_1) V_{in}$$

where

Rf is directly proportional to the Vout

And R1 is inversely proportional to Vout

So by varying the pots Rf & R1 we can adjust the gain of the output.

- Perform the same procedure at different Cutoff frequencies as shown below

Resistance ( $\Omega$ )	Capacitance ( $\mu\text{F}$ )	fh-high cutoff frequency (Hz)
800	0.01	20K
1.59 K	0.01	10K
15.9 K	0.01	1K

### Theoretical Calculations:

Calculate all the following values

1. Pass band gain of Low Pass Filter  $A_F = 1 + R_F / R_1$

=.....

2. Pass band gain (db) =  $20 \log |V_{out}/V_{in}|$

=.....

3. 3 db frequency  $f_H = 1/2\pi RC$

=.....

4. Gain at 3 db frequency  $f_H = 0.707 * A_F$

5. Gain (db) at 3 db frequency  $f_H = 20 \log |V_{out}/V_{in}|$

where  $V_{out} = (2)^{1/2} * V_{in}$

### CONCLUSION:

From the above experiment we studied the active low pass filter and observed its output response by help of CRO.

## EXPERIMENT NO: 10

**AIM OF THE EXPIMENT:** Study of Active High Pass filter and to Evaluate :

1. Low cutoff frequency of High Pass Filter
2. Pass band gain of High Pass Filter
3. Plot the frequency response

**EQUIPMENT REQUIRED:**

SL.NO.	Name of the equipment	Quantity
1	Active filter trainer kit	1
2	Oscilloscope	1
3	Digital Multi meter	2

**THEORY:**

### **High Pass Filter :**

A high-pass filter is a filter that passes high frequencies but attenuates (or reduces) frequencies lower than the cutoff frequency. The actual amount of attenuation for each frequency varies from filter to filter. It is sometimes called a low-cut filter; the terms rumble filter is also used in audio applications. A high-pass filter is the opposite of a low-pass filter.

It is useful as a filter to block any unwanted low frequency components of a complex signal while passing the higher frequencies. Ofcourse, the meanings of 'low' and 'high' frequencies are relative to the cutoff frequency chosen by the filter designer.



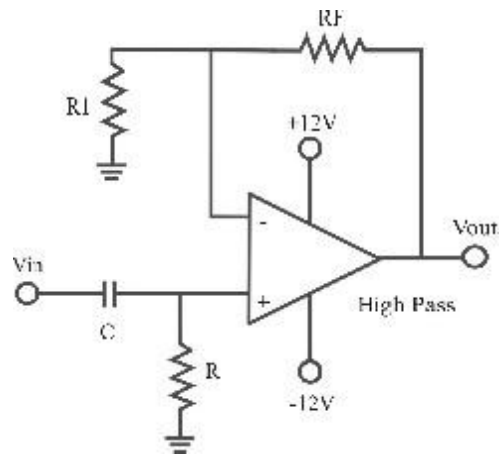

Here also the lower cutoff frequency is given by the same formula that is:

$$f_l = \frac{1}{2\pi RC}$$

$$\frac{1}{2\pi RC}$$

**Frequency Response Curve Of Low Pass Filter :**

**Ideal Frequency Response Curve :**

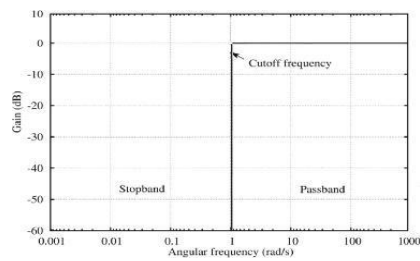

### Practical Frequency Response Curve :

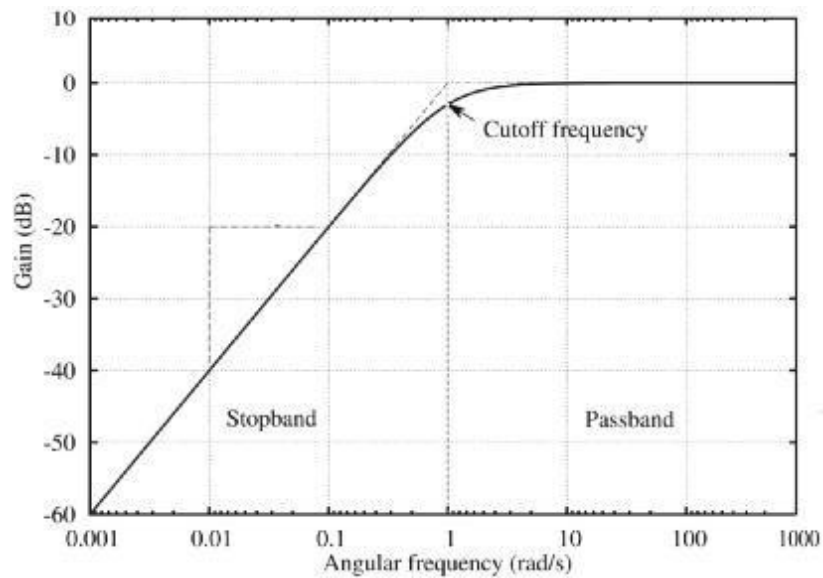

### Applications :

Such a filter could be used to direct high frequencies to a tweeter speaker while blocking bass signals which could interfere with or damage the speaker. A low-pass filter, using a coil instead of a capacitor, could simultaneously be used to direct low frequencies to the woofer.

High-pass and low-pass filters are also used in digital image processing to perform transformations in the spatial frequency domain.

Most high-pass filters have zero gain (-in dB) at DC. Such a high-pass filter with very low cutoff frequency can be used to block DC from a signal that is undesired in that signal (and pass nearly everything else). These are sometimes called DC blocking filters

### CIRCUIT DIAGRAM:

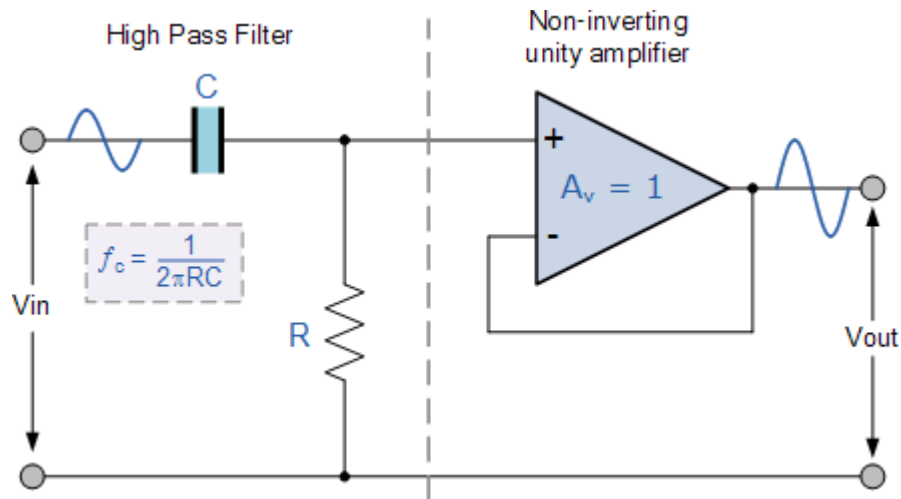

### PROCEDURE:

- Initially rotate potentiometers R1 and Rf in fully clockwise direction in order to make  $R1 = Rf = 10K$ , so that according to the formula given below

$$V_o = (1 + R_f/R_1)V_{in},$$

The gain of the output will be twice of the input.

- The Low cutoff frequency is given by the formula:

$$f_l = \frac{1}{2\pi RC}$$

- Connect an Ohmmeter between TP4 and TP7. Adjust resistance value at 15.9K by varying the potentiometer of 22K to set the Low cutoff frequency ( $f_l$ ) at 1K.
- Connect +12V and -12V DC power supplies at their indicated position from Power Supply section.
- Connect all the ground test points with each other using patch chords.
- Switch 'On' the Power Supply.

- Set the output of function generator at 2 volt, 100 Hz using Oscilloscope with sinusoidal waveform.
- Connect TP1 with  $V_{in}$  of High Pass Filter to give a sinusoidal signal of amplitude 2V (p-p) of frequency 100Hz.
- Observe output on Oscilloscope.
- Similarly you can give the triangular and square wave instead of sinusoidal wave, from the function generator section.
- As we know according to the formula, Output gain is directly proportional to the  $R_f$  and inversely proportional to the  $R_1$ . So, we can adjust the gain of the output by increasing the value of  $R_f$  as well as by decreasing the value of  $R_1$ .
- So, change the values of  $R_1$  and  $R_f$  and observe the change in output.
- Increase the frequency of input signal step by step and observe the effect on output  $V_{out}$  on Oscilloscope.
- Tabulate the values of  $V_{out}$ , gain, gain (db) at different values of input frequency shown in Observation Table.

**OBSERVATION TABLE :**

S. No.	Input frequency (Hz)	Vout	Vout/Vin  = gain	Gain(db) = 20 Log  Vout/Vin
1	100			
2	200			
3	500			
4	1K(fl)			
5	5 K			
6	10 K			
7	15 K			
8	20 K			

- Plot the frequency response of high pass filter using the data obtained at different input frequencies.

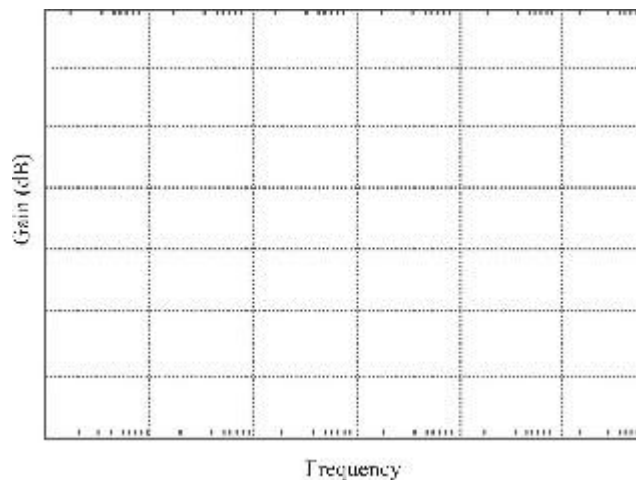

- As we know, according to the formula
 
$$V_{out} = (1+R_f/R_1)*V_{in}$$
 where  
 R<sub>f</sub> is directly proportional to the V<sub>out</sub>  
 And R<sub>1</sub> is inversely proportional to V<sub>out</sub>  
 So by varying the pots R<sub>f</sub> & R<sub>1</sub> we can adjust the gain of the output
- Perform the same procedure at different Cutoff frequencies as shown below:

Resistance ( $\Omega$ )	Capacitance ( $\mu\text{F}$ )	3 db frequency (Hz)
800	0.01	20K
1.59 K	0.01	10K
15.9 K	0.01	1K

**Theoretical Calculations:**

Calculate all the following values

1. Pass band gain of Low Pass Filter  $A_F = 1 + R_F / R_1$   
 =.....
2. Pass band gain (db) =  $20 \log |V_{out}/V_{in}|$   
 =.....
3. Low cutoff frequency  $f_L = 1/2\pi RC$   
 =.....
4. Gain at Low cutoff frequency  $f_L = 0.707 * A_F$
5. Gain (db) at Low cutoff frequency  $f_H = 20 \log |V_{out}/V_{in}|$  where  
 $V_{out} = (2)^{1/2} * V_{in}$

**CONCLUSION**

From the above experiment we studied active high pass filter and observed its output response by the help of CRO.