

C.V. RAMAN POLYTECHNIC, BHUBANESWAR



C.V.Raman Polytechnic

Quality Education for the New Millenium

DEPARTMENT OF CIVIL ENGINEERING

**LECTURE NOTE
ON**

**ESTIMATION & COST EVALUATION- I
(Th.4)**

SEM- 3RD

Prepared by

SUMITRA PARIDA

(Asst. Prof. in Civil Engineering)

INDEX

S.No.	Topic	Page No.
01.	Introduction to the subject	1 - 3
02.	Measurement of Materials & Works	4 - 12
03.	Types of Estimates	13 - 21
04.	Detail & Abstract Estimates of Buildings	22 - 55
05.	Analysis of Rates	56 - 73
06.	Estimation of Quantities of Steel & RCC Elements	74 - 80
07.	Earth Work Calculations	81 - 95
08.	Detailed Estimates	96 - 108
09.	Appendex	109 - 115



INTRODUCTION TO THE SUBJECT

1.1 DEFINITION OF ESTIMATING AND COSTING

Estimating is the technique of calculating or Computing the various quantities and the expected Expenditure to be incurred on a particular work or project.

In case the funds available are less than the estimated cost the work is done in part or by reducing it or specifications are altered, the following requirements are necessary for preparing an estimate.

- a) Drawings like plan, elevation and sections of important points.
- b) Detailed specifications about workmanship & properties of materials etc.
- c) Standard schedule of rates of the current year.

1.2 NEED FOR ESTIMATION AND COSTING

1. Estimate give an idea of the cost of the work and hence its feasibility can be determined i.e whether the project could be taken up with in the funds available or not.
2. Estimate gives an idea of time required for the completion of the work.
3. Estimate is required to invite the tenders and Quotations and to arrange contract.
4. Estimate is also required to control the expenditure during the execution of work.
5. Estimate decides whether the proposed plan matches the funds available or not.

1.3 PROCEDURE OF ESTIMATING OR METHOD OF ESTIMATING.

Estimating involves the following operations

1. Preparing detailed Estimate.
2. Calculating the rate of each unit of work
3. Preparing abstract of estimate

1.4 DATA REQUIRED TO PREPARE AN ESTIMATE

1. Drawings i.e.plans, elevations, sections etc.
2. Specifications.
3. Rates.

1.4.1 DRAWINGS

If the drawings are not clear and without complete dimensions the preparation of estimation become very difficult. So, It is very essential before preparing an estimate.

1.4.2. SPECIFICATIONS

- a) General Specifications: This gives the nature, quality, class and work and materials in general terms to be used in various parts of wok. It helps no form a general idea of building.
- b) Detailed Specifications: These gives the detailed description of the various items of work laying down the Quantities and qualities of materials, their proportions, the method of preparation workmanship and execution of work.

1.4.3. RATES:

For preparing the estimate the unit rates of each item of work are required.

- 1. For arriving at the unit rates of each item.
- 2. The rates of various materials to be used in the construction.
- 3. The cost of transport materials.
- 4. The wages of labour, skilled or unskilled of masons, carpenters, Mazdoor, etc.,

1.5 COMPLETE ESTIMATE:

Most of people think that the estimate of a structure includes cost of land, cost of materials and labour, But many other direct and indirect costs included and is shown below. The Complete Estimate

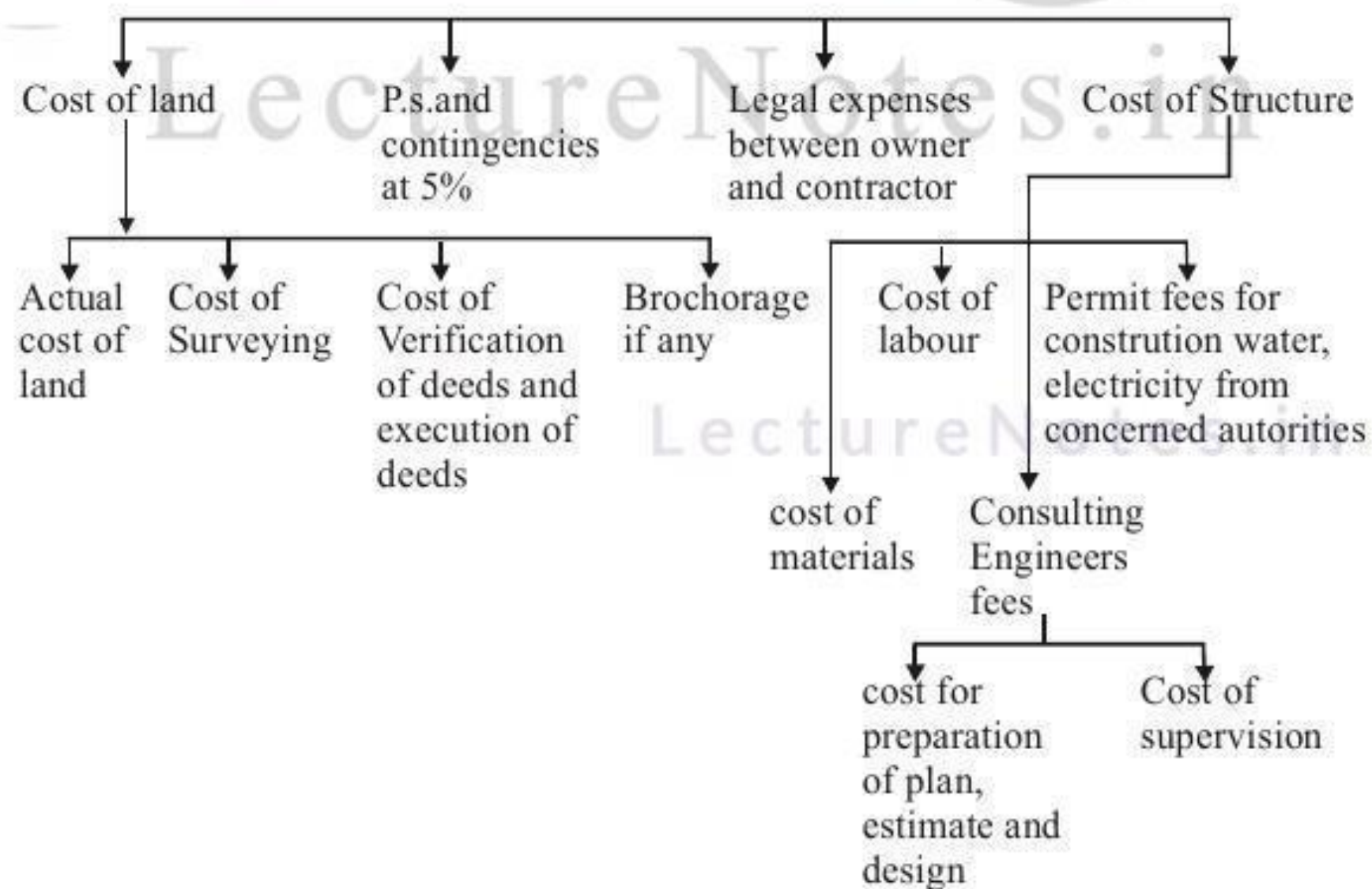

1.6 LUMPSUM:

While preparing an estimate, it is not possible to work out in detail in case of petty items. Items other than civil engineering such items are called lumpsum items or simply L.S. Items.

The following are some of L.S. Items in the estimate.

1. Water supply and sanitary arrangements.
2. Electrical installations like meter, motor, etc.,
3. Architectural features.
4. Contingencies and unforeseen items.

In general, certain percentage on the cost of estimation is allotted for the above L.S. Items

Even if subestimates prepared or at the end of execution of work, the actual cost should not exceed the L.S. amounts provided in the main estimate.

1.7 WORK CHARGED ESTABLISHMENT:

During the construction of a project considerable number of skilled supervisors, work assistance, watch men etc., are employed on temporary basis. The salaries of these persons are drawn from the L.S. amount allotted towards the work charged establishment. that is, establishment which is charged directly to work. an L.S. amount of 1½ to 2% of the estimated cost is provided towards the work charged establishment.

LectureNotes.in

EXERCISE**Short Answer Questions**

1. State the requirements of an estimate?
2. Briefly Explain need for estimation?
3. What is work charged establishment?

MEASUREMENT OF MATERIALS AND WORKS

2.1 UNITS OF MEASUREMENTS:

The units of measurements are mainly categorised for their nature, shape and size and for making payments to the contractor and also. The principle of units of measurements normally consists the following:

- a) Single units work like doors, windows, trusses etc., are expressed in numbers.
- b) Works consists linear measurements involve length like cornice, fencing, hand rail, bands of specified width etc., are expressed in running metres (RM)
- c) Works consists areal surface measurements involve area like plastering, white washing, partitions of specified thickness etc., are expressed in square meters (m²)
- d) Works consists cubical contents which involve volume like earth work, cement concrete, Masonry etc are expressed in Cubic metres.

[BASED ON IS 1200 REVISED]

Sl. No.	Particulas of item	Units of Measurement	Units of payment
I	Earth work:		
	1. Earth work in Excavation	cum	Per ^o %cum
	2. Earthwork in filling in foundation trenches	cum	Per ^o %cum
II	3. Earth work in filling in plinth	cum	Per ^o %cum
	Concrete:		
	1. Lime concrete in foundation	cum	percum
	2. Cement concrete in Lintels	cum	percum
	3. R.C.C.in slab	cum	percum
4. C.C. or R.C.C. Chujja, Sunshade	cum	percum	
5. L.C. in roof terracing (thickness specified)	sqm	persqm	

	6. Cement concrete bed	cum	per cum
	7. R.C. Sunshade (Specified Width & Hight)	cum	1m
III	Damp Proof Course (D.P.C) (Thickness should be mentioned)	sqm	persqm
IV	Brick work:		
	1. Brickwork in foundation	cum	percum
	2. Brick work in plinth	cum	percum
	3. Brick work in super structure	cum	percum
	4. Thin partition walls	sqm	percum
	5. Brick work in arches	cum	percum
	6. Reinforced brick work (R.B. Work)	cum	percum
V	Stone Work:		
	Stone masonry	cum	percum
VI	Wood work:		
	1. Door sand windows frames or chowkhats, rafters beams	cum	percum
	2. Shutters of doors and windows (thickness specified)	sqm	persqm
	3. Doors and windows fittings (like hinges, tower bolts, sliding bolts, handles)	Number	per number
VII	Steel work		
	1. Steel reinforcement bars etc in R.C.C. and R.B.work. quintal	Quintal	per quintal
	2. Bending, binding of steel Reinforcement	Quintal	per quintal
	3. Rivets, bolts, & nuts, Anchor bolts, Lewis bolts, Holding down bolts.	Quintal	per quintal
	4. Iron hold fasts	Quintal	per quintal
	5. Iron railing (height and types specified)	Quintal	per quintal
	6. Iron grills	sqm	per sqm

VIII	Roofing		
	1. R.C.C. and R.B.Slab roof (excluding steel)	cum	per cum
	2. L.C. roof over and inclusive of tiles or brick or stone slab etc (thickness specified)	sqm	per sqm
	3. Centering and shuttering form work	sqm	per sqm
	4. A.C.Sheet roofing	sqm	per sqm
IX	Plastering, points&finishing		
	1. Plastering-Cement or Lime Mortar (thickness and proportion specified)	sqm	per sqm
	2. Pointing	sqm	per sqm
	3. White washing, colour washing, cement wash (number of coats specified)	sqm	per sqm
	4. Distempering (number of coats specified)	sqm	per sqm
	5. Painting, varnishing (number of coats specified)	sqm	per sqm
X	Flooring		
	1. 25mm cement concrete over 75mm lime concrete floor (including L.C.)	sqm	per sqm
	2. 25mm or 40mm C.C. floor	sqm	per sqm
	3. Doors and window sills (C.C. or cement mortar plain)	sqm	per sqm
XI	Rain water pipe /Plain pipe	1RM	per RM
XII	Steel wooden trusses	1No	per 1No
XIII	Glass pannels(supply)	sqm	per sqm
XIV	Fixing of glass panels or cleaning	No	per no.

2.2 RULES FOR MEASUREMENT :

The rules for measurement of each item are invariably described in IS-1200. However some of the general rules are listed below.

1. Measurement shall be made for finished item of work and description of each item shall include materials, transport, labour, fabrication tools and plant and all types of overheads for finishing the work in required shape, size and specification.
2. In booking, the order shall be in sequence of length, breadth and height or thickness.
3. All works shall be measured subject to the following tolerances.
 - i) Linear measurement shall be measured to the nearest 0.01 m.
 - ii) Areas shall be measured to the nearest 0.01 sq.m
 - iii) Cubic contents shall be worked-out to the nearest 0.01 cum
4. Same type of work under different conditions and nature shall be measured separately under separate items.
5. The bill of quantities shall fully describe the materials, proportions, workmanships and accurately represent the work to be executed.
6. In case of masonry (stone or brick) or structural concrete, the categories shall be measured separately and the heights shall be described:
 - a) from foundation to plinth level
 - b) from plinth level to First floor level
 - c) from First floor to Second floor level and so on.

2.3 METHODS OF TAKING OUT QUANTITIES:

The quantities like earth work, foundation concrete, brickwork in plinth and super structure etc., can be worked out by any of following two methods:

- a) Long wall - short wall method
- b) Centre line method.
- c) Partly centre line and short wall method.

a) Long wall-short wall method:

In this method, the wall along the length of room is considered to be long wall while the wall perpendicular to long wall is said to be short wall. To get the

length of long wall or short wall, calculate first the centre line lengths of individual walls. Then the length of long wall, (out to out) may be calculated after adding half breadth at each end to its centre line length. Thus the length of short wall measured into in and may be found by deducting half breadth from its centre line length at each end. The length of long wall usually decreases from earth work to brick work in super structure while the short wall increases. These lengths are multiplied by breadth and depth to get quantities.

b) Centre line method:

This method is suitable for walls of similar cross sections. Here the total centre line length is multiplied by breadth and depth of respective item to get the total quantity at a time. When cross walls or partitions or verandah walls join with main wall, the centre line length gets reduced by half of breadth for each junction. Such junction or joints are studied carefully while calculating total centre line length. The estimates prepared by this method are most accurate and quick.

c) Partly centre line and partly cross wall method:

This method is adopted when external (i.e., around the building) wall is of one thickness and the internal walls having different thicknesses. In such cases, centre line method is applied to external walls and long wall-short wall method is used to internal walls. This method suits for different thicknesses walls and different level of foundations. Because of this reason, all Engineering departments are practicing this method.

P.B.-1: From the Drawing given below determine (a) Earth work excavation (b) CC (1:5:10) Bed (c) R.R.Masonry in C.M. (1:6) (d) Brick Work in C.M.(1:6).

Single Roomed Building (Load Bearing type structure)

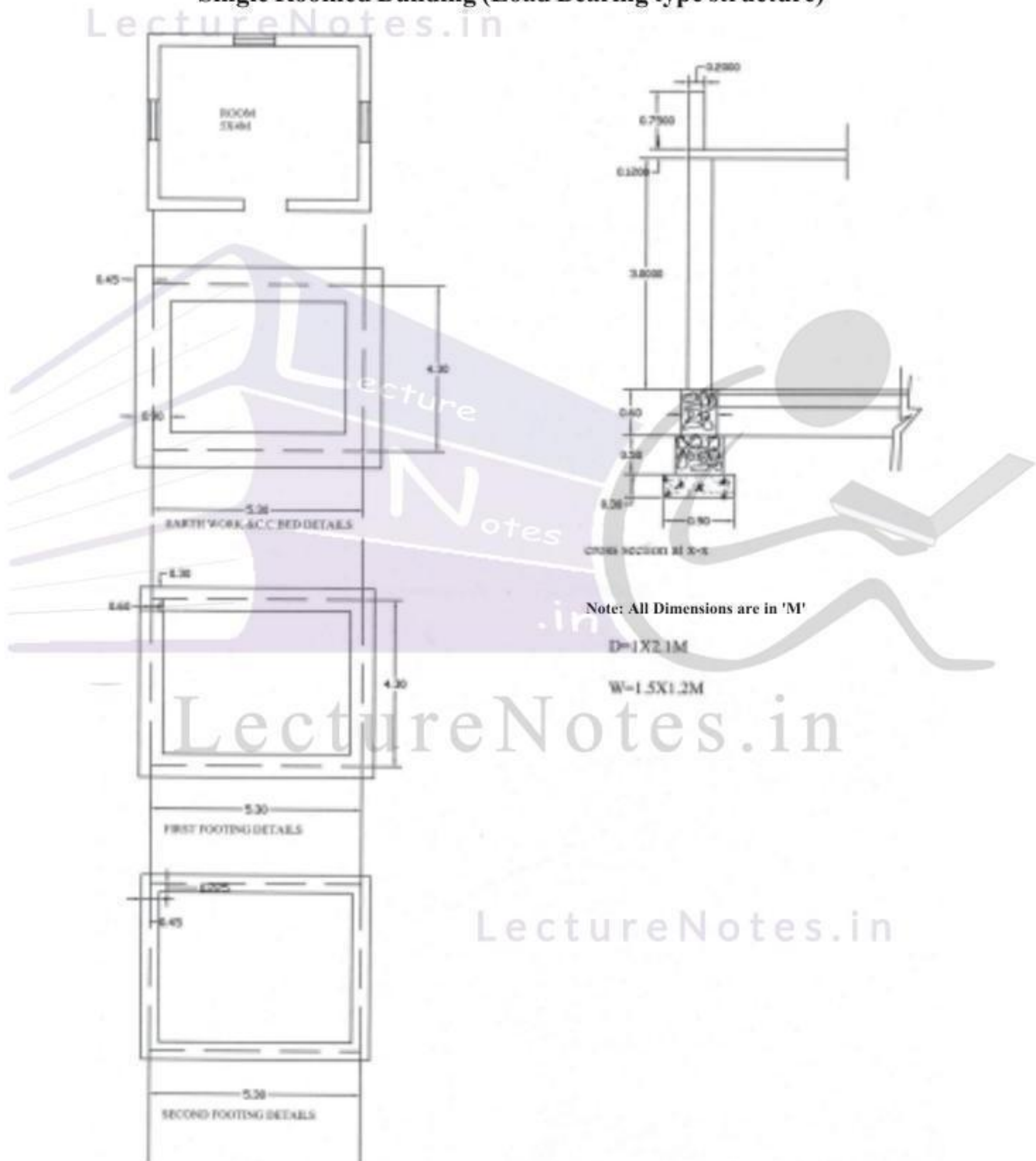

Long wall - Short wall Method

S.No.	Particulars of Items	No.	L	B	H	Q	Explanation
1.	Earth Work excavation for foundation						
	a) Long walls	2	6.2	0.9	1.4	15.264	$L=5.3+0.45+0.45=6.2$ $D=0.3+0.5+0.6=1.4$
	b) Short walls	2	3.4	0.9	1.4	8.568	$L=4.3-0.45-0.45=3.4$
					Total	24.192	m³
2.	C.C.(1:4:8) bed for foundation						
	a) Long walls	2	6.2	0.9	0.3	3.348	
	b) Short walls	2	3.4	0.9	0.3	1.836	
					Total	5.184	m³
3.	R.R.Masonry in CM (1:6) for						
	a) Footings						
	i) Long walls	2	5.9	0.6	0.5	3.54	$L=5.3+0.3+0.3=5.9$
	ii) Short walls	2	3.7	0.6	0.5	2.22	$L=4.3-0.3-0.3=3.7$
					Total	5.76	m³
	b) Basement						
	i) Long walls	2	5.75	0.45	0.6	3.105	$L=5.3+0.225+0.225=5.75$
	ii) Short walls	2	3.85	0.45	0.6	2.079	$L=4.3-0.225-0.225=3.85$
					Total	5.184	m³
	Total R.R. Masonry for footings and Basement						= 5.76+5.184 = 10.94 m³
4.	Brick masonry with CM (1:6) for super structure						
	a) Long Wall	2	5.6	0.30	3.00	10.08	$L=5.3+0.15+0.15=5.6$
	b) Short walls	2	4.0	0.30	3.00	7.20	$L=4.3-0.15-0.15=4.0$
					Total	17.28	m³

Centre Line Method

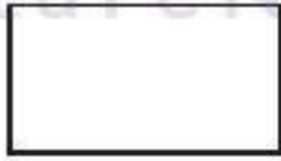
S.No.	Particulars of Items	No.	L	B	H	Q	Explanation
1.	Earth Work excavation for foundation 5.3  4.3	1	19.2	0.9	1.4	24.192	m^3 $L=2(5.3+4.3)=19.2$
2.	C.C.(1:4:8) bed for foundation	1	19.2	0.9	0.3	5.184	m^3
3.	R.R.Masonry in CM (1:6) for a) Footings b) Basement	1 1	19.2 19.2	0.6 0.45	0.5 0.6	5.76 5.184	
					Total	10.944	m^3
4.	Brick masonry with CM(1:6) for super structure	1	19.2	0.3	0.3	17.28	m^3

LectureNotes.in

LectureNotes.in

EXERCISE

I. Short Answer Questions

1. List the difference between centre line method and long wall-short wall method of taking out measurements.
2. What are the rules to be followed while taking the measurements?
3. Mention the units for the following items.
 - a) flooring
 - b) R.R.Masonry
 - c) Plastering for pointing
 - d) Damp proof course
 - e) R.C. sunshade (Specified width and thickness)

II. Essay type questions

1. From the Drawing given below determine (a) Earth work excavation (b) CC (1:5:10) Bed (c) R.R.Masonry in C.M. (1:6) (d) Brick Work in C.M.(1:6). by
 - (a) longwall - short wall method
 - (b) Centre line Method

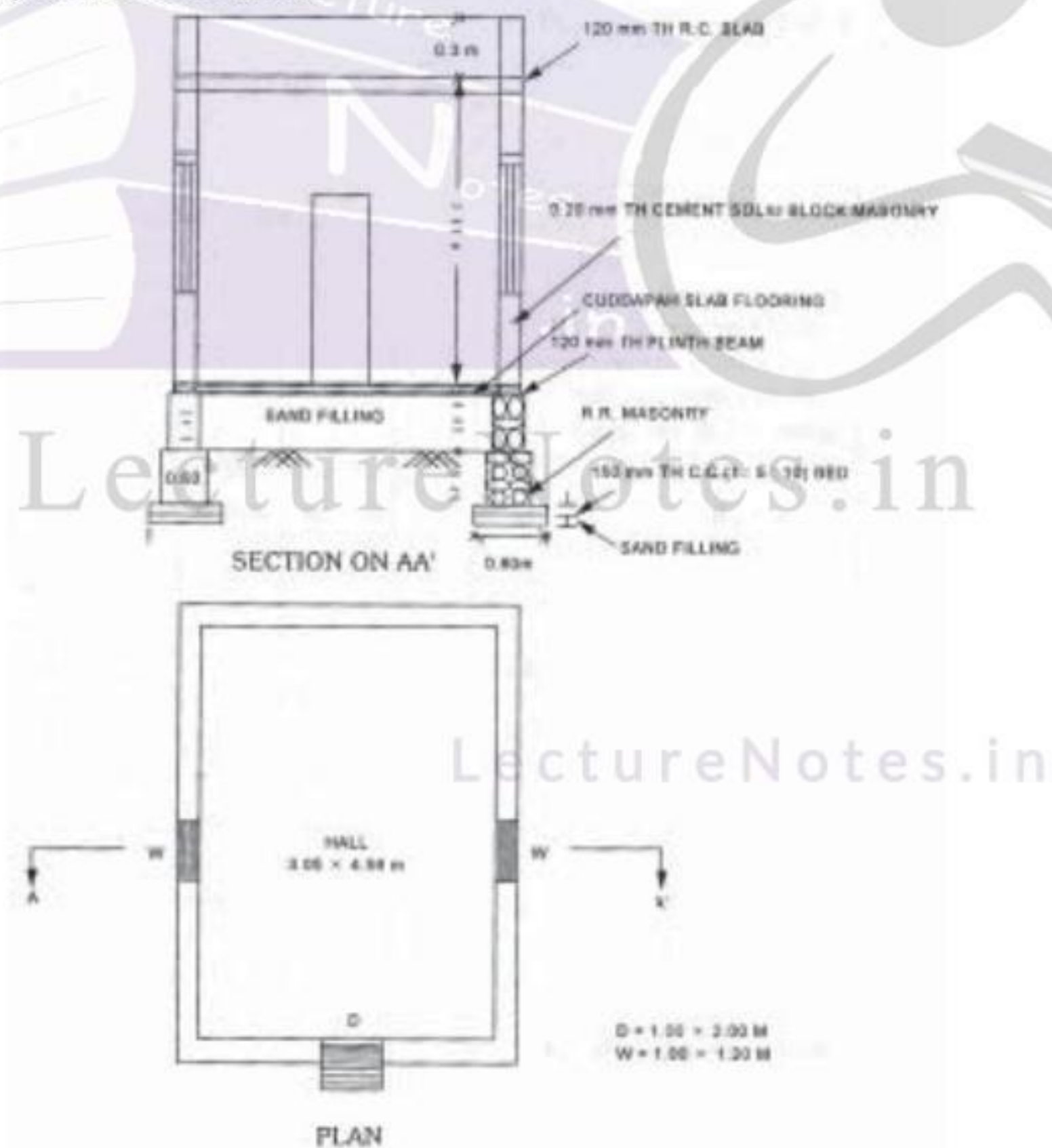



TYPES OF ESTIMATES

3.1 DETAILED ESTIMATE:

The preparation of detailed estimate consists of working out quantities of various items of work and then determine the cost of each item. This is prepared in two stages.

i) Details of measurements and calculation of quantities:

The complete work is divided into various items of work such as earth work concreting, brick work, R.C.C. Plastering etc., The details of measurements are taken from drawings and entered in respective columns of prescribed proforma. the quantities are calculated by multiplying the values that are in numbers column to Depth column as shown below:

Details of measurements form

S.No.	Description of Item	No	Length (L) m	Breadth (B) m	Depth/Height (D/H)m	Quantity	Explanatory Notes

ii) Abstract of Estimated Cost :

The cost of each item of work is worked out from the quantities that already computed in the details measurement form at workable rate. But the total cost is worked out in the prescribed form is known as abstract of estimated form. 4%of estimated Cost is allowed for Petty Supervision, contingencies and Unforeseen items.

ABSTRACT OF ESTIMATE FORM

Item No.	Description/ Particulars	Quantity	Unit	Rate	Per (Unit)	Amount

The detailed estimate should accompanied with

- i) Report
- ii) Specification
- iii) Drawings (plans, elevation, sections)
- iv) Design charts and calculations
- v) Standard schedule of rates.

3.1.1. Factors to be considered While Preparing Detailed Estimate:

- i) **Quantity and transportation of materials:** For bigger project, the requirement of materials is more. such bulk volume of materials will be purchased and transported definitely at cheaper rate.
- ii) **Location of site:** The site of work is selected, such that it should reduce damage or in transit during loading, unloading, stocking of materials.
- iii) **Local labour charges:** The skill, suitability and wages of local labourers are considered while preparing the detailed estimate.

3.2 DATA:

The process of working out the cost or rate per unit of each item is called as Data. In preparation of Data, the rates of materials and labour are obtained from current standard scheduled of rates and while the quantities of materials and labour required for one unit of item are taken from Standard Data Book (S.D.B)

3.2.1 Fixing of Rate per Unit of an Item:

The rate per unit of an item includes the following:

- i) **Quantity of materials & cost:** The requirement of materials are taken strictly in accordance with standard data book(S.D.B). The cost of these includes first cost, freight, insurance and transportation charges.
- ii) **Cost of labour:** The exact number of labourers required for unit of work and the multiplied by the wages/ day to get of labour for unit item work.
- iii) **Cost of equipment (T&P):** Some works need special type of equipment, tools and plant. In such case, an amount of 1 to 2% of estimated cost is provided.
- iv) **Overhead charges:** To meet expenses of office rent, depreciation of equipment salaries of staff postage, lighting an amount of 4% of estimate cost is allocated.

3.3 METHODS OF PREPARATION OF APPROXIMATE ESTIMATE:

Preliminary or approximate estimate is required for studies of various aspects of work of project and for its administrative approval. It can decide, in case of commercial projects, whether the net income earned justifies the amount invested or not. The approximate estimate is prepared from the practical knowledge and cost of similar works. The estimate is accompanied by a report duly explaining necessity and utility of the project and with a site or layout plan. A percentage 5 to 10% is allowed for contingencies. The following are the methods used for preparation of approximate estimates.

- a) Plinth area method
- b) Cubical contents methods
- c) Unit base method.

a) Plinth area method: The cost of construction is determined by multiplying plinth area with plinth area rate. The area is obtained by multiplying length and breadth (outer dimensions of building). In fixing the plinth area rate, careful observation and necessary enquiries are made in respect of quality and quantity aspect of materials and labour, type of foundation, height of building, roof, wood work, fixtures, number of storeys etc.,

As per IS 3861-1966, the following areas include while calculating the plinth area of building.

Types of Estimates

16

- a) Area of walls at floor level.
- b) Internal shafts of sanitary installations not exceeding 2.0m², lifts, airconditioning ducts etc.,
- c) Area of barsati at terrace level:
Barsati means any covered space open on one side constructed on one side constructed on terraced roof which is used as shelter during rainy season.
- d) Porches of non cantilever type.

Areas which are not to include

- a) Area of lofts.
- b) Unenclosed balconies.
- c) Architectural bands, cornices etc.,
- d) Domes, towers projecting above terrace level.
- e) Box louvers and vertical sunbreakers.

b) Cubical Contents Method: This method is generally used for multistoreyed buildings. It is more accurate than the other two methods viz., plinth area method and unit base method. The cost of a structure is calculated approximately as the total cubical contents (Volume of buildings) multiplied by Local Cubic Rate. The volume of building is obtained by Length x breadth x depth or height. The length and breadth are measured out to out of walls excluding the plinth off set.

The cost of string course, cornice, corbelling etc., is neglected.

The cost of building = volume of buildings x rate / unit volume.

c) Unit Base Method: According to this method the cost of structure is determined by multiplying the total number of units with unit rate of each item. In case schools and colleges, the unit considered to be as 'one student' and in case of hospital, the unit is 'one bed'. The unit rate is calculated by dividing the actual expenditure incurred or cost of similar building in the nearby locality by the number of units.

Problems on Plinth Area Method

Example 3.1: Prepare an approximate estimate of building project with total plinth area of all building is 800 sqm. and from following data.

- i) Plinth area rate Rs. 4500 per sqm
- ii) Cost of water supply @7½% of cost of building.
- iii) Cost of Sanitary and Electrical installations each @ 7½% of cost of building.
- iv) Cost of architectural features @1% of building cost.
- v) Cost of roads and lawns @5% of building cost.
- vi) Cost of P.S. and contingencies @4% of building cost.

Determine the total cost of building project.

Solution :

Data given:

Plinth area = 800m².

Plinth area rate = Rs. 4500 per Sqm.

∴ Cost of building = 800 x 4500 = Rs. 36,00,000=00

Add the cost of the water supply charges @7½%

$$= \frac{36,00,000 \times 7.5}{100} = 2,70,000 = 00$$

Add the Cost of Sanitary and electrical installation @ 15%

$$= \frac{36,00,000 \times 15}{100} = 5,40,000 = 00$$

Add the cost of architectural features @1%

$$= \frac{36,00,000 \times 1}{100} = 36,000 = 00$$

Add the cost of Roads Lawns @ 5% = $\frac{36,00,000 \times 5}{100} = 1,80,000 = 00$

Add the Cost of P.S. and contingencies @ 4%

$$= \frac{36,00,000 \times 4}{100} = 1,44,000 = 00$$

Total Rs. 47,70,000=00

Assume Add supervision charges 8% on overall cost

$$= 47,70,000 \times \frac{8}{100} = 3,81,600 = 00$$

Grand Total Rs. 51,51,600=00

Example 3.2 : The plinth area of an apartment is 500 sqm. Determine the total cost of building from the following data:

- Rate of construction = Rs.1230/--per m³.
- The height of apartment = 16.25 m
- Water Supply, Sanitary and Electrical installations each at 6% of building cost.
- Architectural appearance @ 1% of building cost.
- Unforeseen item @2% of Building cost.
- P.S. and contingencies @4% of building.

Solution :

a) The Cost of building = cubic content x cubic rate
 $= 500 \times 16.25 \times 1230 = \text{Rs. } 99,93,750/-$

b) Provision for water supply, sanitary and Electrical installations water supply and sanitation each @ 6%
 $= \frac{99,93,750 \times 18}{100} = \text{Rs. } 17,98,875/-$

i.e total percent = $3 \times 6 = 18\%$ building cost

c) Architectural appearance @1% = $\frac{99,93,750 \times 1}{100} = \text{Rs. } 99,937/-$

d) Unforeseen items @2% = Rs. 1,99,875/-

e) P.S. and contingencies @4% = Rs. 3,99,750/-

Total = Rs.1,24,92,187/-

Sundries = 7,813/-

Total cost of the building project = Grand Total = Rs.1,25,00,000/-

Example 3.3: The plinth area and plinth area rate of a residential building are 100 sqm and Rs. 5000/- respectively. Determine the total cost of building assuming suitable provisions.

Solution :

$$\text{Cost of building} = 100 \times 5000 = \text{Rs. } 5,00,000$$

Cost of water supply and

$$\text{sanitary fittings @15\%} = \frac{5,00,000 \times 15}{100} = \text{Rs. } 75,000$$

$$\text{Cost of Electrification @7\frac{1}{2}\%} = \frac{5,00,000 \times 7.5}{100} = \text{Rs. } 37,500$$

$$\text{Cost of Roads \& Lawns @5\%} = \frac{5,00,000 \times 5}{100} = \text{Rs. } 25,000$$

$$\text{Cost of P.S. \& contingencies @4\%} = \frac{5,00,000 \times 4}{100} = \text{Rs. } 20,000$$

$$\text{Total Cost Rs. } \underline{\underline{6,57,500/-}}$$

Example 3.4 : Prepare an approximate Estimate of a proposed building from the following?

Plinth area of the building = 226 sqm.

Cost of the structure = 2500 per sqm.

Water supply and sanitary arrangements = 12½%

Electrification = 7%

Fluctuation of rates = 5%

petty supervision charges = 3%

sol: Cost of Building = $226 \times 2500 = \text{Rs. } 5,65,000$

Water supply & Sanitary arrangements @ 12½ %

$$= \frac{5,65,000 \times 12.5}{100} = \text{Rs. } 70,625$$

$$\text{Electrification @7\%} = \frac{5,65,000 \times 7}{100} = \text{Rs. } 39,550$$

$$\text{Fluctuation of rates 5\%} = \frac{5,65,000 \times 5}{100} = \text{Rs. } 28,250$$

$$\text{Petty supervision charges 3\%} = \frac{5,65,000 \times 3}{100} = \text{Rs. } 16,950$$

$$\text{Total Cost Rs.} = \underline{\underline{7,19,750.00}}$$

Problem on Cubical content Method:

Example 3.5 : Prepare the rough estimate for a proposed commercial complex for a municipal corporation for the following data.

Plinth Area = 500m²/floor

Ht of each storey = 3.5m

No. of storeys = G+2

Cubical content rate = Rs. 1000/m³

Provided for a following as a percentage of structured cost

a) water supply & Sanitary arrangement	-8%
b) Electrification	-6%
c) Fluctuation of rates	-5%
d) Contractors profit	-10%
e) Petty supervision & contingencies	-3%

Sol : Cubical content = No. of storeys (Plinth Area x height of each storey)
 = 3(500x3.5) = 5250m³

Structural cost = Cubical content x cubical content rate
 = 5250 x 1000 = 52.5 Lakhs

other provisions:-

a) Water supply and sanitation = 52.5x8/100 = Rs.4.2 Lakhs

b) Electrification = 52.5 x 6/100 = Rs.3.15 lakhs

c) fluctuation of rates = 52.5 x 5/100 = Rs.2.625

Total = Rs. 9.975 Lakhs

Structural cost = Rs. 52.500 Lakhs

Total = Rs.62.475 Lakhs

d) P.S./& contingencies = 62.475 x 3/100 = Rs.1.874 Lakhs

e) Contractors Profit = 62.475 x 10/100 = Rs.6.247 Lakhs

Total Cost = Rs.70.596 Lakhs

Problems on Unit Base Method:

Example 3.6: Prepare an approximate estimate or rough cost estimate of a hospital building for 50 beds. The cost of construction altogether for each bed is Rs. 60,000/-. Determine the total cost of hospital building.

Solution:

No. of beds = 50

Cost of construction = Rs. 60,000/-

Total Cost of Hospital building = $50 \times 60,000 = \text{Rs. } 30,00,000/-$

Example 3.7: To prepare the rough cost estimate of a hostel building which accommodate 150 students. The cost of construction including all provisions is Rs. 15,000/- per student. Determine total cost of building.

Solution :

No. of students = 150

Cost of construction including all L.S. provisions = Rs. 15,000/-

Total Cost of hostel building = $150 \times 15000 = \text{Rs. } 22,50,000/-$

(Rupees twenty two lakhs, fifty thousands only)

EXERCISE**I. SHORT ANSWER QUESTIONS:**

1. List the factors to be considered while preparing detailed estimate and explain briefly?
2. What are the differences between plinth area method and Unit base method?
3. List the requirements of data preparation.

II ESSAY TYPE QUESTIONS:

1. Prepare the approximate cost of building project (group Housing)
 - i) No. of houses = 150
 - ii) Plinth area of each dwelling = 600m^2
 - iii) Plinth area rate = Rs. 5,000/- per m^2
 - iv) Cost of water supply & sanitary arrangements @ $12\frac{1}{2}\%$
 - v) Electrification at $7\frac{1}{2}\%$ of cost of building.
 - vi) Cost of roads & Lawns @ 5%
 - vii) Cost of P.S. & contingencies @ 4%
2. Prepare a rough cost estimate of a cinema theatre which accommodate 1700 seats. The cost of construction including all provisions is Rs. 6000/- per seat.
3. What are the methods of preparation of approximate estimates and explain briefly.

Chapter

4

DETAIL & ABSTRACT ESTIMATES OF BUILDINGS

Example 1: From the given figure below calculate the detailed and abstract estimate for the single roomed building (Load bearing type structure) by

a) long wall & short wall method (b) Centre Line Method

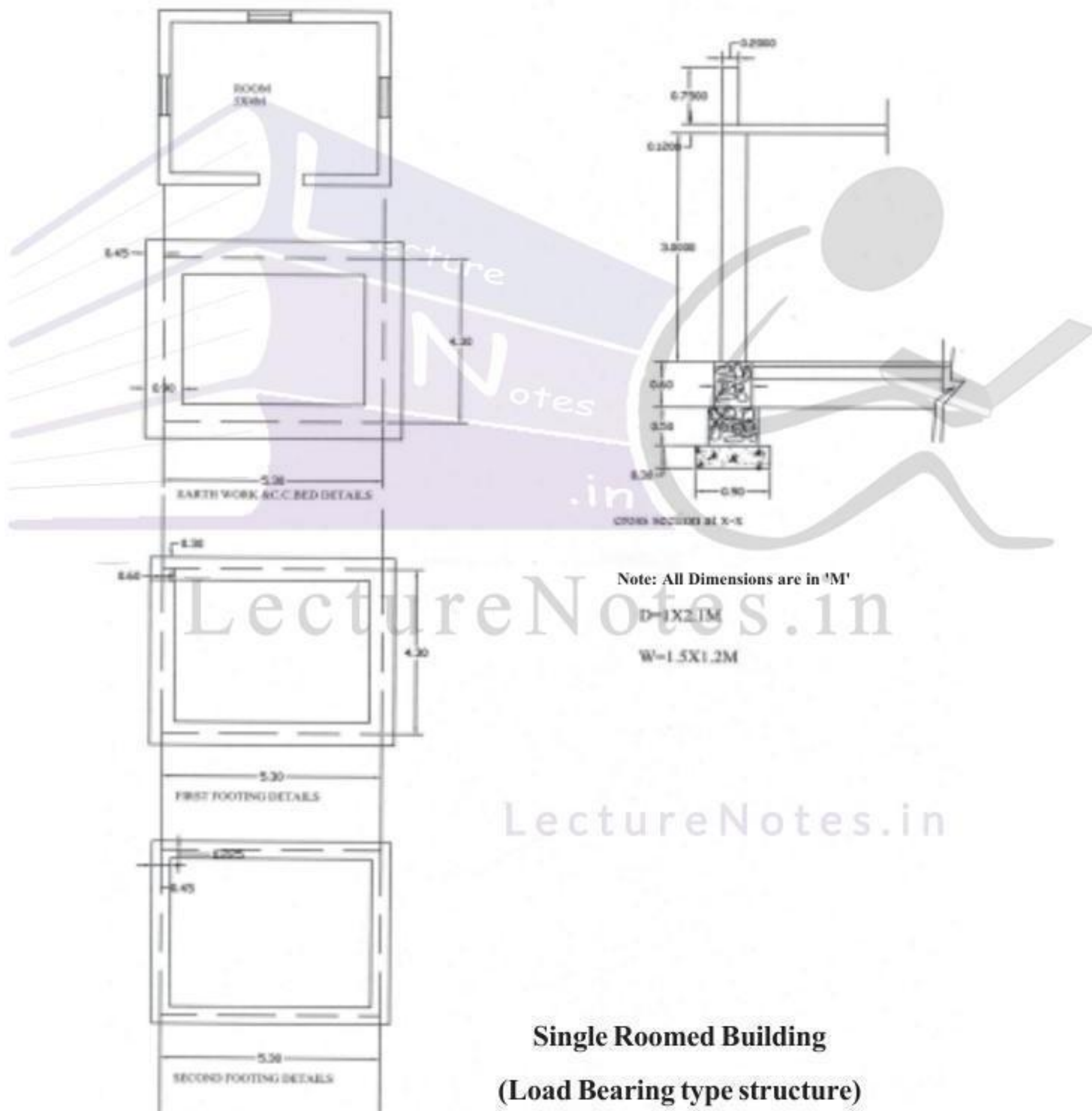

a) Long wall - Short Method

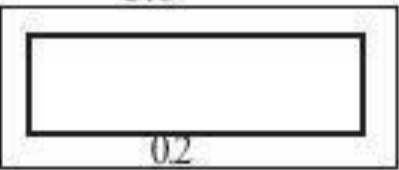
S.No.	Particulars of Items	No.	L	B	H	Q	Explanation
1.	Earth Work excavation for foundation						
	a) Long walls	2	6.2	0.9	1.4	15.264	$L=5.3+0.45+0.45=6.2$ $D=0.3+0.5+0.6=1.4$
	b) Short walls	2	3.4	0.9	1.4	8.568	$L=4.3-0.45-0.45=3.4$
					Total	24.192	m³
2.	C.C.(1:4:8) bed for foundation						
	a) Long walls	2	6.2	0.9	0.3	3.348	
	b) Short walls	2	3.4	0.9	0.3	1.836	
					Total	5.184	m³
3.	R.R.Masonry in CM (1:6) for						
	a) Footings						
	i) Long walls	2	5.9	0.6	0.5	3.54	$L=5.3+0.3+0.3=5.9$
	ii) Short walls	2	3.7	0.6	0.5	2.22	$L=4.3-0.3-0.3=3.7$
					Total	5.76	m³
	b) Basement						
	i) Long walls	2	5.75	0.45	0.6	3.105	$L=5.3+0.225+0.225=5.75$
	ii) Short walls	2	3.85	0.45	0.6	2.079	$L=4.3-0.225-0.225=3.85$
					Total	5.184	m³
	Total R.R. Masonry for footings and Basement						= 5.76+5.184 = 10.94 m³
4.	Brick masonry with CM (1:6) for super structure						
	a) Long Walls	2	5.6	0.30	3.00	10.08	$L=5.3+0.15+0.15=5.6$
	b) Short walls	2	4.0	0.30	3.00	7.20	$L=4.3-0.15-0.15=4.0$
	c) for parapet wall						
	5.6						
							
	a) Long Walls	2	5.6	0.2	0.75	1.68	
	b) Short walls	2	4.4	0.2	0.75	1.32	
					Total	20.28	m³

S.No.	Particulars of Items	No.	L	B	H	Q	Explanation
	Deductions for openings						
	a) Doors	1	1.0	0.3	2.1	0.63	
	b) Windows	3	1.5	0.3	1.2	1.62	
					Total	(-)2.25	m³
	Net Brick Masonry		= 20.28			- 2.25 =	18.03m³
5.	R.C.C. (1:2:4) for						
	a) Roof slab	1	5.6	4.6	0.12	3.090	
	b) Lintels over						
	i) Doors	1	1.2	0.3	0.15	0.054	
	ii) Windows	3	1.5	0.3	0.15	0.202	
	c) Beams						
	i) Long beams	2	5.6	0.3	0.3	1.008	
	ii) short beams	2	4.0	0.3	0.3	0.720	
					Total	5.074	m³
6.	Sandfilling for basement	1	4.85	3.85	0.48	8.96	L=5.0-0.075-0.075=4.85
7	C.C.(1:4:8) for flooring	1	4.85	3.85	0.1	1.86	B=4.0-0.075-0.075=3.85
8	Flooring with Mosaic tiles	1	5.0	4.0	--	20.0	m²
9	Plastering with CM (1:6)for super structure						
	Inside						
	For walls	1	18.0	--	3.0	54.0	L=2(5.0+4.0)=18.0
	Out side						
	For walls	1	20.4	--	3.87	61.2	L=2(5.6+4.6)=20.4
	Basement outside	1	21.6	--	0.6	12.96	H=3.0+0.12+0.75=3.87
	Parapet wall						(upto parapet wall)
	a) Inside	1	18.8	--	0.75	14.1	
	b) top	1	19.6	0.2	---	3.92	
	Deductions for openings				Total	146.18	m²
	Doors	1x2	1.0	--	2.1	4.2	
	Windows	3x2	1.5	--	1.2	10.8	
						15.0	m²
	Net Plastering		= 146.18			- 15.0	= 131.18 m²

S.No.	Particulars of Items	No.	L	B	H	Q	Explanation
10	Plastering for Ceiling with CM(1:5)	1	5.0	4.0	--	20.0	m ²
11	White Washing with two coats with Janatha cement						
	Same as quantity of plastering for walls and ceiling					151.18	(=131.18+20=151.18)
12.	Colour washing with two coats						
	Same as quantity of plastering for walls and ceiling					151.18	(=131.18+20)151.18)
13	Supply & Fixing of best country wood for						
	a) Doors	1				1 No.	
	b) Windows	3				3No.	
14	Painting with ready mixed synthetic enamil paints with two coats over primary coat for new wood for						
	a) Doors	2 ¹ / ₄ x1	1.0	---	2.1	4.725	
	b) Windows	2 ¹ / ₄ x3	1.5	---	1.2	12.15	
					Total	16.875	m ²
15	Petty supervision and contingencies at 4% and rounding off.						

b) Centre Line Method

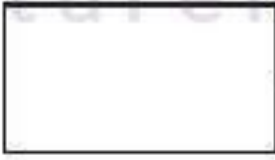
S.No.	Particulars of Items	No.	L	B	H	Q	Explanation
1.	Earth Work excavation for foundation 5.3  4.3	1	19.2	0.9	1.4	24.192	m³ $L=2(5.3+4.3)=19.2$
2.	C.C.(1:4:8) bed for foundation	1	19.2	0.9	0.3	5.184	m³
3.	R.R.Masonry in CM (1:6) for						
	a) Footings	1	19.2	0.6	0.5	5.76	
	b) Basement	1	19.2	0.45	0.6	5.184	
					Total	10.944	
4.	Brick masonry with CM(1:6) for super structure For parapet wall Deductions for openings						
	a) Doors	1	1.0	0.3	2.1	0.63	
	b) Windows	3	1.5	0.3	1.2	1.62	
					Total	(-)2.25	m³
	Net Brick Masonry =		17.28	+3.0	-2.25 =	18.03	m³
5.	R.C.C. (1:2:4) for						
	a) roof slab	1	5.6	4.6	0.12	3.090	
	b) Lintels over						
	i) Doors	1	1.2	0.3	0.15	0.054	
	ii) Windows	3	1.5	0.3	0.15	0.202	
	c) beams	1	19.2	1.3	0.3	1.728	
					Total	5.074	m³
6.	Sandfilling for basement	1	4.85	3.85	0.48	8.96	$L=5.0-0.075-0.075=4.85$
7	C.C.(1:4:8) for flooring	1	4.85	3.85	0.1	1.86	$B=4.0-0.075-0.075=3.85$

8.	flooring with Mosaic tiles	1	5.0	4.0	--	20.0	
9	Plastering with CM (1:6) for super structure						
	<u>Inside</u>						
	For walls	1	18.0	--	3.0	54.0	
	<u>Out side</u>						
	For walls	1	20.4	--	3.87	61.2	
	Basement outside	1	21.6	--	0.6	12.96	
	Parapet wall						
	a) Inside	1	18.8	--	0.75	14.1	
	b) top	1	19.6	0.2	---	3.92	
	Deductions for openings				Total	146.18	m²
	Doors	1x2	1.0	--	2.1	4.2	$L=5.0-0.075-0.075=4.85$
	Windows	3x2	1.5	--	1.2	10.8	$B=4.0-0.075-0.075=3.85$
						15.0	m²
	Net Plastering =		146.18-15	=		131.18	m²
10	Plastering for Ceiling with CM(1:5)	1	5.0	4.0	--	20.0	m²
11	White Washing with two coats with Janatha cement						
	Same as quantity of plastering for walls and ceiling					151.18	m² (131.18+20=151.18)
12.	Colour washing with two coats						
	Same as quantity of plastering for walls and ceiling					151.18	m²
13	Supply & Fixing of best country wood for						
	a) Doors	1				1 No.	
	b) Windows	3				3No.	

S.No.	Particulars of Items	No.	L	B	H	Q	Explanation
14	Painting with ready mixed synthetic enamel paints with two coats over primary coat for new wood for						
	a) Doors	2 ¹ / ₄ x 1	1.0	---	2.1	4.725	
	b) Windows	2 ¹ / ₄ x 3	1.5	---	1.2	12.15	
					Total	16.875	m²
15	Petty supervision and contingencies at 4% and rounding off.						

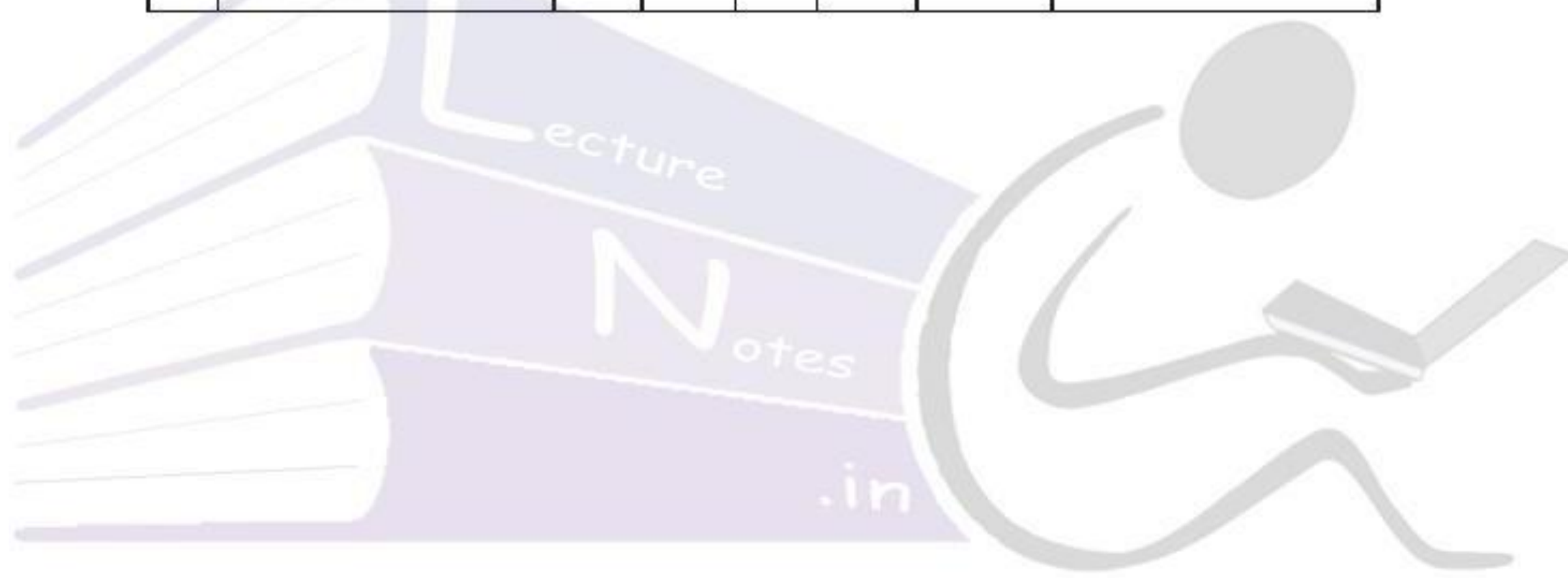

LectureNotes.in

LectureNotes.in

Abstract estimate of single roomed building (load bearing structure)

S.No.	Description of item	Quantity	Unit	Rate	Per	Amount
1.	Earth work excaation	24.192	m ³	465	10m ³	1125.00
2.	Cement concrete(1:4:8)	5.184	m ³	4545	1m ³	8009.30
3.	RR.masonry in C.M.(1:5)	10.94	m ³	1391	m ³	15217.50
4.	Sand filling in basement	8.96	m ³	195.20	10m ³	175.00
5.	Brick masonry in country bricks of standard size in CM(1:8)	18.03	m ³	2291	m ³	41306.73
6.	R.C.C. (1:2:4) for lintels, beams etc.	1.984	m ³	6030	m ³	11963.52
7.	R.C.C.(1:2:4) for slabs,	3.09	m ³	6030	m ³	18633.00
8.	Cement concrete (1:5:10) for flooring	1.86	m ³	1452	m ³	2700.72
9.	Supplying and fixing of country wood for doors.	2.1	m ²	1650	m ²	3465.00
10.	Supplying and fixing of country wood for windows and ventilators.	5.4	m ²	2300	m ²	12420.00
11.	Plastering to all exposed surfaces of brick work and basement with C.M (1:5)	151.18	m ²	582	10m ²	8798.70
12.	White washing with best shell lime	151.18	m ²	116	10m ²	1753.68
13.	Flooring with spartek tiles set in C.M (1:3)	20	m ²	4230	10m ²	8460.00
14.	Painting with ready mixed enamel paint	16.875	m ²	335	10m ²	565.31
					Total	134593.46
15.	Povision for water supply and sanitary arrangements @12.5%					16824.18
16.	Provision for electrification @7.5%					10094.50
17.	Povision for architectural appearance @2%					2691.86
18.	Provision for unforeseen items 2%					2691.86
19.	Provision for P.s.and contingencies @4%					5383.73

Grand Total Rs. 172279.65

Example :2 :-From the given figure below calculate the details and abstract estimate for the double roomed building (Load bearing type structure) by a) long wall & short wall method (b) Centre Line Method

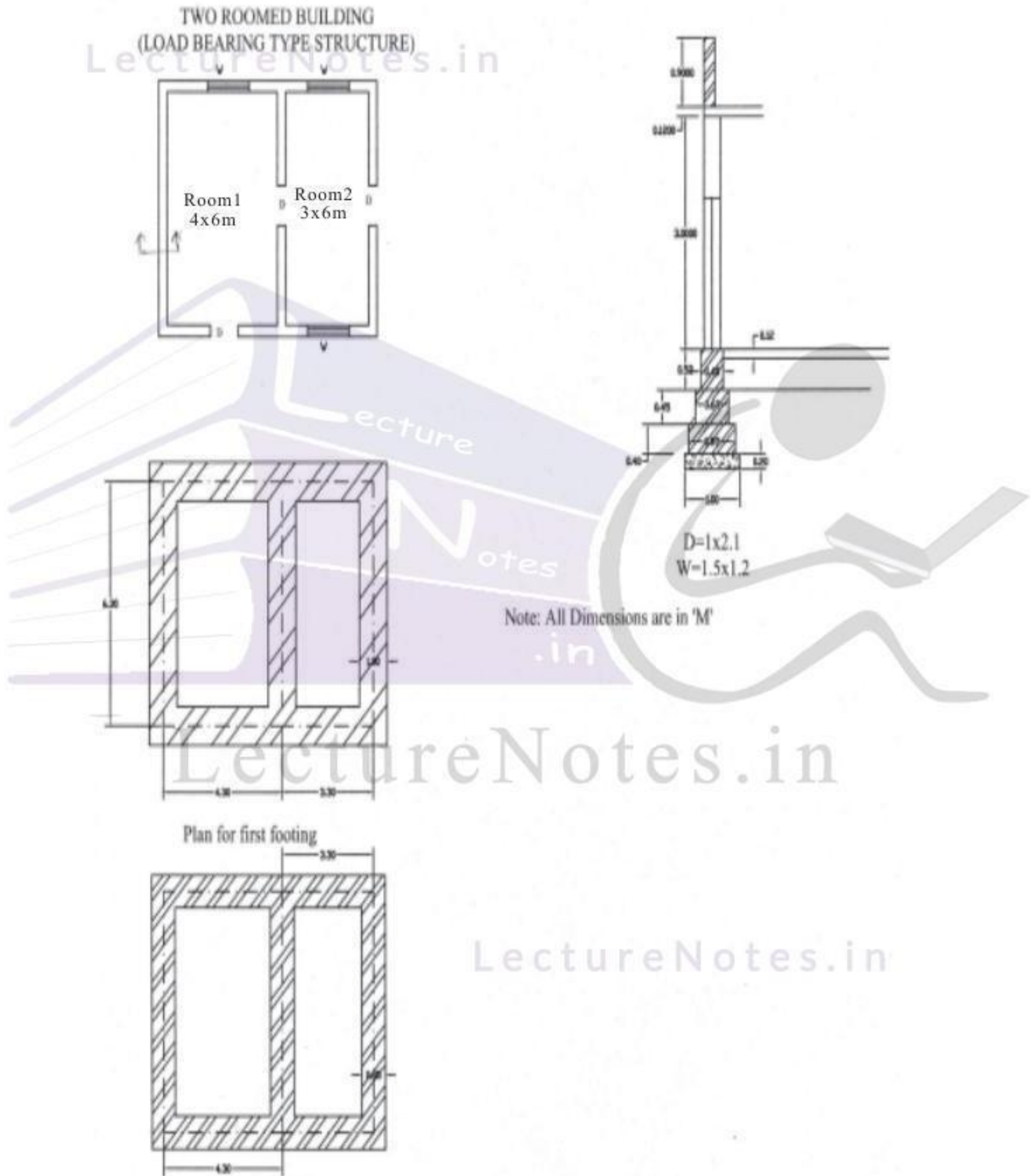

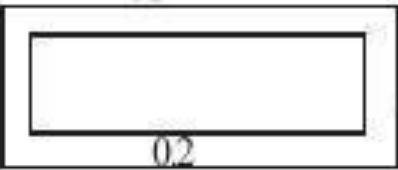
S.No.	Particulars of Items	No	L	B	H	Q	Explanation
1.	Earth Work excavation for foundation						
	a) Long walls	2	8.6	1.0	1.05	18.05	$L=7.6+0.5+0.5=8.6$
	b) Short walls	3	5.3	1.0	11.05	16.70	$L=6.3-0.5-0.5=5.3$
					Total	34.75	m³
2.	C.C.(1:4:8) bed for foundation						
	a) Long walls	2	8.6	1.0	0.2	3.44	
	b) Short walls	3	5.3	1.0	0.2	3.18	
					Total	6.62	m³
3.	Brick masonry for footings with CM(1:4)						
	first footing						
	a) Long walls	2	8.45	0.85	0.4	5.746	$L=7.6+0.425+0.425=8.45$
	b) Short walls	3	5.45	0.85	0.4	5.560	$L=6.3-0.425-0.425=5.45$
	2nd footing						
	a) Long walls	2	8.20	0.6	0.45	4.428	$L=7.6+0.3+0.3=8.2$
	b) short walls	3	5.70	0.6	0.45	4.617	$L=6.3-0.3-0.3=5.7$
	ii) for base ment						
	long walls	2	8.00	0.4	0.4	2.560	$L=7.6+0.2+0.0=8.0$
	short walls	3	5.90	0.4	0.4	2.832	$L=6.3-0.2-0.2=5.9$
	iii) for super structure						
	long walls	2	7.90	0.3	3.0	14.22	$L=7.6+0.15+0.15=7.9$
	short walls	3	6.00	0.3	3.0	16.20	$L=6.3-0.15-0.15=6.0$
	iv) Parapet wall						
	7.9						
							
	a) long walls	2	7.90	0.2	0.70	2.212	
	b) Shot walls	2	6.20	0.2	0.70	1.736	
					Total	60.11	
	Deductions for openings						
	Doors	3	1.0	0.3	2.1	1.89	
	Windows	3	1.5	0.3	1.2	1.62	
	Lintels over doors	3	1.20	0.3	0.10	0.108	
	windows	3	1.70	0.3	0.10	0.153	
	Net B.M.=60.11-377=56.34m ³				Total	3.771	

4	RCC(1:2:4)for						
	a) roof slab	1	7.9	6.6	0.12	6.256	
	b) for lintles over doors	3	1.2	0.3	0.1	0.108	
	Windows	3	1.7	0.3	0.1	0.153	
	c) beams	1	33.8	0.3	0.3	3.042	
					Total	9.298	m³
5.	Plastering for walls	1	20.0	--	3.0	60.00	L=2(4.0+6.0)=20
	a) Inside room1	1	18.0	---	3.0	54.00	
	room2	1	29.0	---	3.0	87.00	L=2(7.9+6.6)=29
	b) out side	1×2	28.2	---	0.70	39.48	L=2(7.7+6.4)=28.2
	Parapet wall(Sides)	1×1	28.2	0.20	--	5.64	
					Total	246.12	m²
	Deductions						
	a) doors	3×2	1.0	---	2.10	12.6	
	b) windows	3×2	1.5		1.20	10.8	
					Total	23.4	m²
	Net Plastering					= 246.12- 23.4 =	222.72 m²
6.	flooring with cuddapah slab in cm (1:3)						
	Room1	1	4.0	6.0	---	24	
	Room2	1	3.0	6.0	---	18	
					Total	42	m²
7	Plastering for ceiling = same as flooring					42	
8	White washing = same as plastering for walls & Ceiling					= 222.72 + 42 = 264.72	m²
9	Colour washing with two coats					264.72	m²
	Same as quantity of plastering for walls and ceiling					264.72	m²
10	Supply & Fixing of best country wood for						
	a) Doors	3				3Nos.	
	b) Windows	3				3 Nos	
11	Painting with ready mixed synthetic enamel paints two coats over primary coat for new wood for						
	a) Doors	2¼x3	1.0	--		14.175	
	b) Windows	2¼x3	1.5	--		11.13	
						25.305	m²
12	2% unforeseen items						
13	4% P.S& contingencies and round off.						

b) Centre Line Method

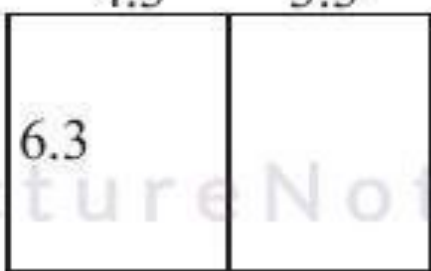
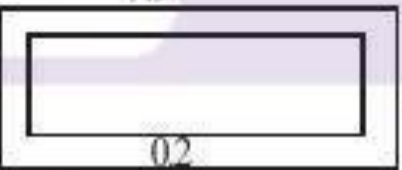
S.No.	Particulars of Items	No.	L	B	H	Q	Explanation
	<div style="display: flex; justify-content: space-around; width: 100px;"> 4.3 3.3 </div>  <p style="text-align: center;">6.3</p>						
	<p>Total centre line length $= (4.3+3.3) \times 2 + 6.3 \times 3 = 34.1 \text{m}$</p>						
1.	Earth work excavation	1	33.1	1.0	1.05	34.75	$L=34.1-2 \times 1/2=33.1$
2.	C.C.(1:4:8) bed for foundation	1	33.1	1.0	0.20	6.62	m^3
3.	Brick masonry with CM(1:4)						
	a) for foundation						
	i) first footing	1	33.25	0.85	0.40	11.30	$L=34.1-0.85=33.25$
	ii) 2nd footing	1	33.50	0.60	0.45	9.045	$L=34.1-0.6 \times 2/2$
	b) for basement	1	33.7	0.40	0.40	5.392	$L=34.1-0.4 \times 2/2$
	c) for super structure	1	33.80	0.30	3.0	30.42	$L=34.1-0.3 \times 2/2$
	d) for parapet wall						
	<div style="display: flex; justify-content: space-around; width: 100px;"> 7.9 6.6 </div>  <p style="text-align: center;">0.2</p>						
	<p>Total centre line length $= 2(7.7+6.4)=28.2$</p>	1	28.2	0.2	0.70	3.948	
					Total	60.10	m^3
	Deductions for						
	Openings Doors	3	1.0	0.3	2.1	1.89	
	windows	3	1.5	0.3	1.2	1.62	
	Lintels Doors	3	1.2	0.3	0.1	0.108	
	Windows	3	1.7	0.3	0.1	1.153	
					Total	3.771	m^3
	Net B.M.=60.11-3.771=56.34m³						
4.	Quantity of R.C.C.Roof, Plastering for walls and ceiling and flooring, White washing is same as Longwall & Short wall method.						

Abstract estimate of two roomed building (Load bearing type structure)

S.No.	Description of item	Quantity	Unit	Rate	Per	Amount
1.	Earth work excavation	34.75	m ³	465	10m ³	1615.90
2.	Cement concrete(1:4:8)	6.62	m ³	1545	1m ³	10228.00
3.	Sand filling in basement	12.036	m ³	195.20	10m ³	235.00
4.	Brick masonry in country Bricks of standard size in CM(1:8)	56.34	m ³	2291	m ³	129075.00
5.	R.C.C. (1:2:4) for lintels, beams etc.	3.303	m ³	6030	m ³	19918.00
6.	R.C.C.(1:2:4) for slabs,	6.26	m ³	6030	m ³	37748.00
7.	Cement concrete (1:5:10) for flooring	4.2	m ³	1452	m ³	6098.40
8.	Supplying and fixing of country wood for doors.	6.3	m ³	1650	m ²	10395.00
9.	Supplying and fixing of country wood for windows and ventilators.	5.4	m ²	2300	m ²	12420.00
10.	Plastering to all exposed surfaces of brick work and basement with C.M (1:5)	222.72	m ²	582	10m ²	12962.30
11	White washing with best shell lime	264.72	m ²	116	10m ²	3070.75
12	Flooring with spartek tiles set in C.M (1:3)	42	m ²	4230	10m ²	17766.00
13	Painting with ready mixed enamel paint	25.305	m ²	335	10m ²	8477.17
						128090.00
14	Provision for water supply and sanitary arrangements @12.5%					16011.25
15	Provision for electrification @7.5%					9606.75
16	Provision for architectural appearance @2%					2561.80
17	Provision for unforeseen items 2%					2561.80
18	Provision for P.S.and contingencies @4%					5123.60
					Grand Total	163955.23

Example 3 :- From the given figure below calculate the details and abstract estimate for the single Storeyed residential building with no of rooms (Load bearing type structure) by Centre Line Method

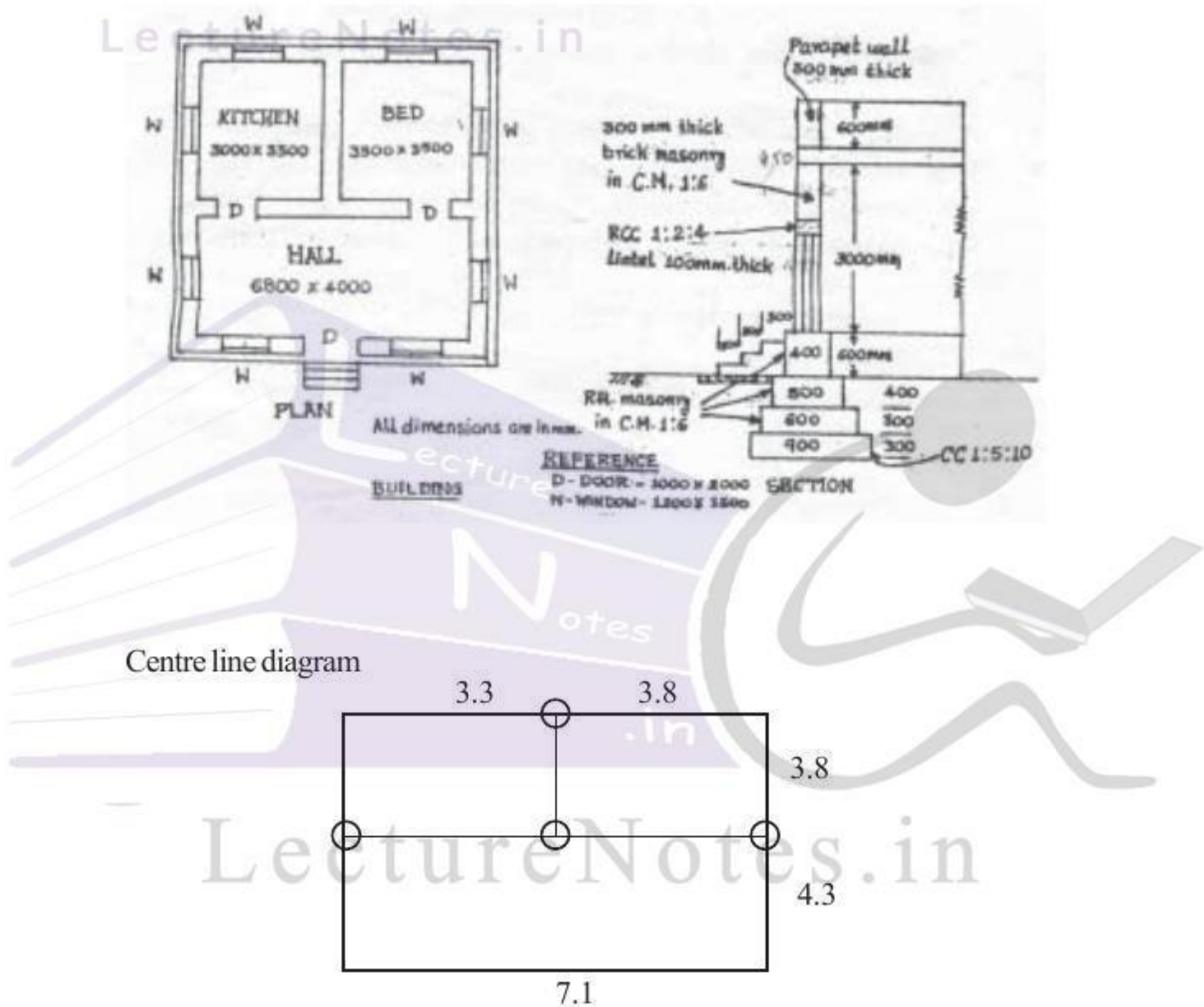

Total centre line length = $(3.3+3.8)3+3.8\times 3+4.3\times 2=41.3\text{m}$

no of T Junctions = 4

S.No.	Particulars of Items	No	L	B	H	Q	Explanation
1.	Earth work Excavation	1	39.5	0.9	1.0	35.55	$41.3-4 \times 0.9/2=39.5$
2.	C.C. bed (1:5:10)	1	39.5	0.9	0.3	10.665	m^3
3.	R.R. Masomary in CM 1:6						
	Ist Footing	1	40.1	0.6	0.3	7.218	$41.3-4 \times 0.6/2=40.1$
	IInd Footing	1	40.3	0.5	0.4	8.06	$41.3-4 \times 0.5/2=40.3$
	Basement	1	40.5	0.4	0.6	9.72	$41.3-4 \times 0.4/2=40.5$
					Total	25.00	m^3
4.	Damp proof course over basement around the building with CC (1:2:4)	1	40.5	0.6	---	16.2	m^2
	Deduct for Door sills	3	1.0	0.3		- 0.9	m^2
	Net Quantity = $16.2-0.9=15.3$ sq.m				---		
5.	First class brick work in wall in						
	a) superstructure with CM 1:6	1	40.7	0.3	3.0	36.63	$L = 41.3-4 \times 0.3/2$
	b) Parapet wall	1	30.4	0.3	0.6	5.472	$L=2(7.1+8.1)$
			7.1		Total	42.102	m^3
		8.4			8.1		
	Deductions:						
	Doors	3	1.0	0.3	2.0	1.80	
	Windows	8	1.2	0.3	1.5	4.32	
	Lintel opening over						
	Doors	3	1.2	0.3	0.1	0.108	Asue 100mm
	Windows	8	1.4	0.3	0.1	0.336	projection on either
					Total	6.564	side
	Net Quantity of BM = $42.102-6.564 = 35.538$ m^3						
6.	Plastering with 12mmth in CM 1:5	1x2	40.1	---	3.0	240.6	$L=41.3-4 \times 0.3=40.1$
	Deductions for openings						

S.No.	Particulars of Items	No.	L	B	H	Q	Explanation
	Doors	3x2	1.0	---	2.0	12.0	
	windows	8x2	1.2	---	1.5	28.8	
					Total	40.8	m²
	Plastering for parapet wall (sides)	1x2	30.4	---	0.6	36.48	
	Top	1	30.4	0.3	---	9.12	
					Total	45.60	m²
	Net Plastering = 240.6 - 40.8 + 45.6 = 245.4 m ²						
7.	Flooring with 25mmth CC(1:2:4)						
	Kitchen	1	3.0	3.5	--	10.5	
	Bed	1	3.5	3.5	--	12.25	
	Hall	1	6.8	4.0	--	27.20	
	Sills of Doors	3	1.0	0.3	--	0.90	
8.	Ceiling = Same as Flooring				Total	50.85	m²
						50.85	m²
9.	white washing = Same as Plastering for walls and ceiling 245.4 + 50.85 = 296.25 m ²						
10.	RCC(1:2:4) for						
	a) Slab	1	7.40	8.40	1.5	9.324	
	b) lintels over Doors	3	1.2	0.3	0.1	0.108	
	Windows	8	1.4	0.3	0.1	0.336	
	c) beams	1	40.7	0.3	0.3	3.663	
					Total	13.431	m³
11	Supply & Fixing of best country wood for						
	a) Doors	3				3Nos.	
	b) Windows	8				8 Nos	
12	Painting with ready mixed synthetic enamel paints two coats over primary coat for new wood for						
	a) Doors	2 1/4 x 3	1.0	--	2.0	13.50	
	b) Windows	2 1/4 x 8	1.2	--	1.5	32.40	
						45.90	m²
13	2% unforeseen items						
14	4% P.S & contingencies and round off.						

Detail & Abstract Estimates of Buildings

38

Abstract estimate of single storeyed residential building with no of rooms (lead beary type)

S.No.	Description of item	Quantity	Unit	Rate	Per	Amount
1.	Earth work excavation	35.55	m ³	465	10m ³	1653.00
2.	Cement concrete(1:4:8)	10.665	m ³	1545	1m ³	164.77.50
3.	RR.masonry in C.M.(1:5)	25.00	m ³	1391	m ³	34775.00
4.	Sand filling in basement	23.775	m ³	195.20	10m ³	464.00
5.	Brick masonry in country bricks of standard size in CM(1:8)	35.535	m ³	2291	m ³	81417.60
6.	R.C.C. (1:2:4) for lintels, beams etc.	4.107	m ³	6030	m ³	24765.20
7.	R.C.C.(1:2:4) for slabs,	9.324	m ³	6030	m ³	56223.70
8.	Cement concrete (1:5:10) for flooring	5.085	m ³	1452	m ³	7383.40
9.	Supplying and fixing of country wood for doors.	6.00	m ²	1650	m ²	9900.00
10.	Supplying and fixing of country wood for windows and ventilators.	14.40	m ²	2300	m ²	33120.00
11	Plastering to all exposed surfaces of brick work and basement with C.M (1:5)	245.40	m ²	582	10m ²	14282.30
12	White washing with best shell lime	296.25	m ²	116	10m ²	3436.50
13	Flooring with spartek tiles set in C.M (1:3)	50.85	m ²	4230	10m ²	21509.50
14	Painting with ready mixed enamel paint	45.90	m ²	335	10m ²	1537.65
						<u>306945.35</u>
15	Provision for water supply and sanitary arrangements @12.5%					38368.20
16	Provision for electrification @7.5%					23020.90
17	Provision for architectural appearance @2%					6138.90
18	Provision for unforeseen items 2%					6138.90
19	Provision for P.S.and contingencies @4%					12277.80
						<u>392890.00</u>

Example 4:- From the given figure below calculate the details and abstract estimate for the single storeid residential building with no.of rooms (Framed Structured type) by Centre Line Method

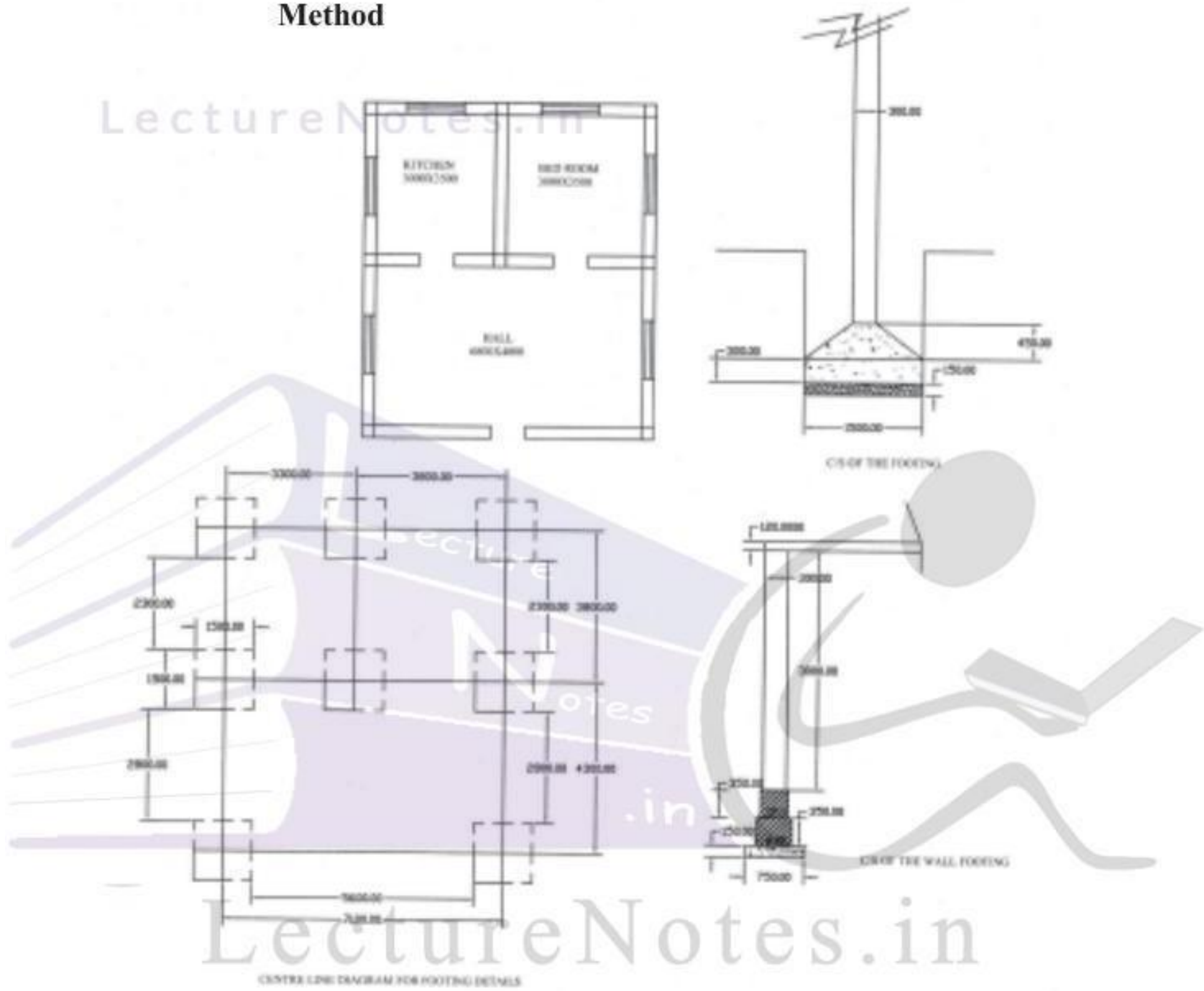

S.No.	Particulars of Items	No	L	B	H	Q	Explanation
1	Earth work excavation for foundation for						
	a) pillars	8	1.5	1.5	1.80	32.4	
	b) around the building and cross walls	1	26.3	0.75	0.85	27.9	$L = 5.6 + 2.8 \times 2 + 2.3 \times 3 + (1.8 + 2.3) \times 2$
					Total	60.3	m^3
2.	C.C. (1:4:8) for						
	a) pillars	8	1.5	1.5	0.15	2.7	
	b) around the building and cross walls	1	38.3	0.75	0.15	4.3	$L = 3.5 \times 3 + 3 \times 2 + 3.5 \times 2 + 4 \times 2 + 6.8 = 38.3$
					Total	7.0	m^3
3.	Brick Masonry with C.M. (1:6) for						
	a) first footing	1	38.3	0.45	0.35	6.03	
	b) Second Footing	1	38.3	0.35	0.30	4.69	
	c) Superstructure	1	38.3	0.3	3.0	4.02	
	d) Parapet wall	1	30.4	0.3	0.6	5.47	$L = (7.1 + 8.1) \times 2 = 30.4$
					Total	20.21	m^3
		7.1		8.1			
			6.8	7.8			
			0.3				
	Deduction for opening						
	a) Doors	3	1.0	0.3	2.0	1.8	
	b) Windows	8	1.2	0.3	1.5	4.32	
					Total	6.12	m^3
	Net Brick Masonry	= 20.21 - 6.12			=	14.09	
4.	R.C.C. (1:1.5:3) for columns						
	a) Rectangular portion	8	1.5	1.5	0.3	5.40	
	b) Trepezoidal portion	8	0.9	0.9	0.45	2.92	
	c) Square portion upto GL	8	0.3	0.3	0.9	0.65	
	d) Square portion above GL	8	0.3	0.3	3.0	2.16	
					Total	11.13	m^3
5.	Plastering with 12mmth in CM 1:5	1x2	40.1	---	3.0	240.6	$L = 41.3 - 4 \times 0.3 = 40.1$
	Deductions for openings						

S.No.	Particulars of Items	No.	L	B	H	Q	Explanation
	Doors	3x2	1.0	---	2.0	12.0	
	windows	8x2	1.2	---	1.5	28.8	
					Total	40.8	m²
	Plastering for parapet wall (sides)	1x2	30.4	---	0.6	36.48	
	Top	1	30.4	0.3	---	9.12	
					Total	45.60	m²
	Net Plastring = $240.6 - 40.8 + 45.6 = 245.4 \text{ m}^2$						
6.	Flooring with 25mmth CC(1:2:4)						
	Kitchen	1	3.0	3.5	--	10.5	
	Bed	1	3.5	3.5	--	12.25	
	Hall	1	6.8	4.0	--	27.20	
	Sills of Doors	3	1.0	0.3	--	0.90	
7.	Ceiling = Same as Flooring				Total	50.85	m²
						50.85	
8.	white Washing = Same as Plastering for walls and ceiling $245.4 + 50.85 = 296.25 \text{ m}^2$						
9.	RCC(1:2:4) for						
	a) Slab	1	7.40	8.40	1.5	9.324	
	b) lintels over Doors	3	1.2	0.3	0.1	0.108	
	Windows	8	1.4	0.3	0.1	0.336	
	c) beams	1	40.7	0.3	0.3	3.663	
					Total	13.431	m³
10	Supply & Fixing of best county wood for						
	a) Doors	3				3Nos.	
	b) Windows	8				8 Nos	
11	Painting with ready mixed synthetic enamel paints two coats over primary coat for new wood for						
	a) Doors	2 1/4 x 3	1.0	--	2.0	13.50	
	b) Windows	2 1/4 x 8	1.2	--	1.5	32.40	
						45.90	m²
12	2% unforeseen items						
13	4% P.S & contingencies and round off.						

Abstract estimate of single storeyed residential building (framed structure type)

S.No.	Description of item	Quantity	Unit	Rate	Per	Amount
1.	Earth work excavation	60.30	m ³	465	10m ³	2804.00
2.	Cement concrete(1:4:8)	7.00	m ³	1545	1m ³	10815.00
3.	Brick masonry in country bricks of standard size in CM(1:5) Reefs columns	14.09	m ³	2291	10m ³	32250.20
4.	R.C.C. (1:2:4) for lintels, beams, columns etc.	15.237	m ³	7405	m ³	112830.00
5.	R.C.C.(1:2:4) for slabs,	9.324	m ³	6030	m ³	56223.70
6.	Cement concrete (1:5:10) for flooring	5.085	m ³	1452	m ³	7383.40
7.	Supplying and fixing of country wood for doors.	6.00	m ³	1650	m ²	9900.00
8.	Supplying and fixing of country wood for windows and ventilators.	14.40	m ²	2300	m ²	33120.00
9.	Plastering to all exposed surfaces of brick work and basement with C.M (1:5)	245.40	m ²	582	10m ²	14282.30
10	White washing with best shell lime	296.25	m ²	116	10m ²	3436.50
11	Flooring with spartek tiles set in C.M (1:3)	50.85	m ²	4230	10m ²	21509.50
12	Painting with ready mixed enamel paint	51.00	m ²	335	10m ²	1708.50
13	Provision for staircase	LS	m ²			50000.00
14	Provision for water supply and sanitary arrangements @12.5%					354584.60
15	Provision for electrification @7.5%					44323.00
16	Provision for architectural appearance @2%					26593.80
17	Provision for unforeseen items 2%					7091.70
18	Provision for P.s.and contingencies @4%					7091.70
						14183.40

Total Rs. 453868.00

Example 5 :- From the given figure below calculate the details and abstract estimate for the two storeyed residential building with no. of rooms (Framed Structured type) by Centre Line Method

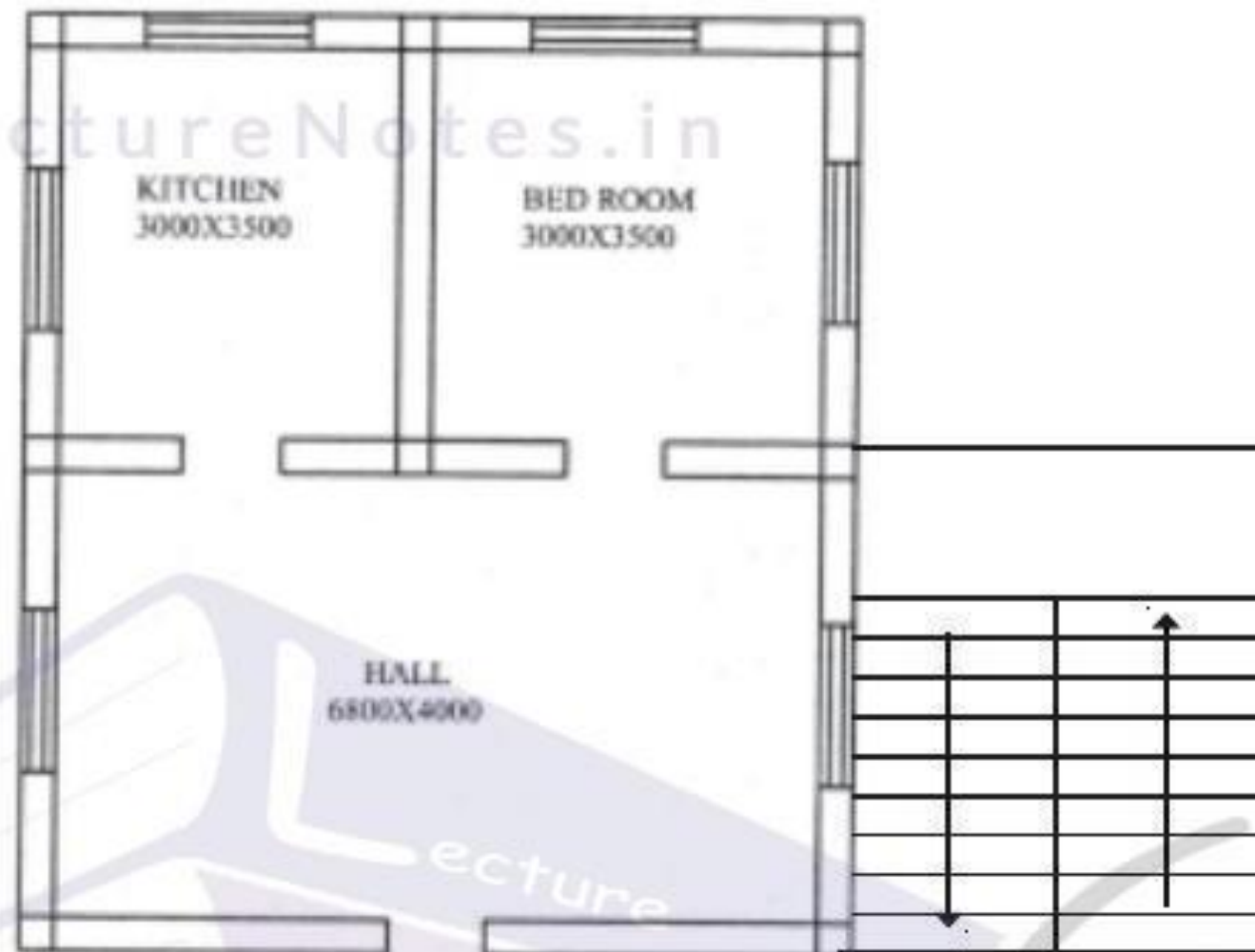

Ground Floor Plan



First Floor Plan

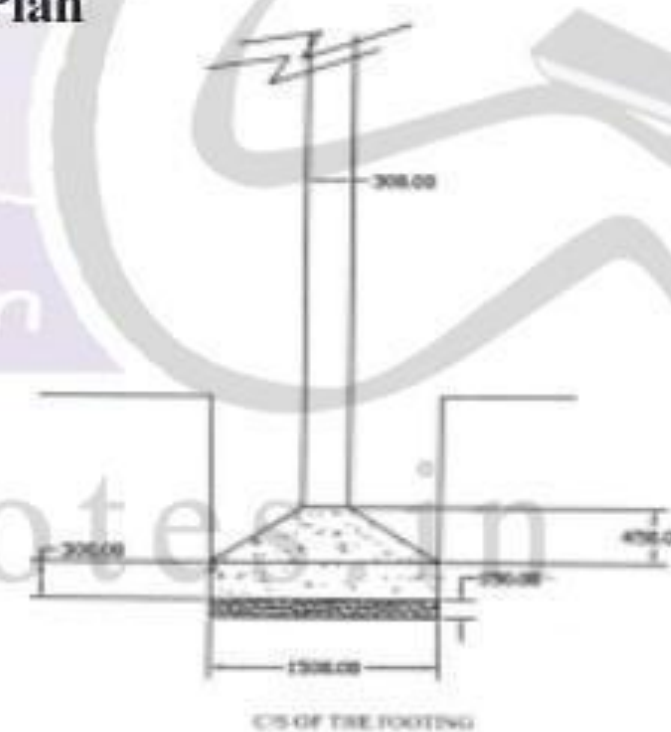

C/S OF THE FOOTING

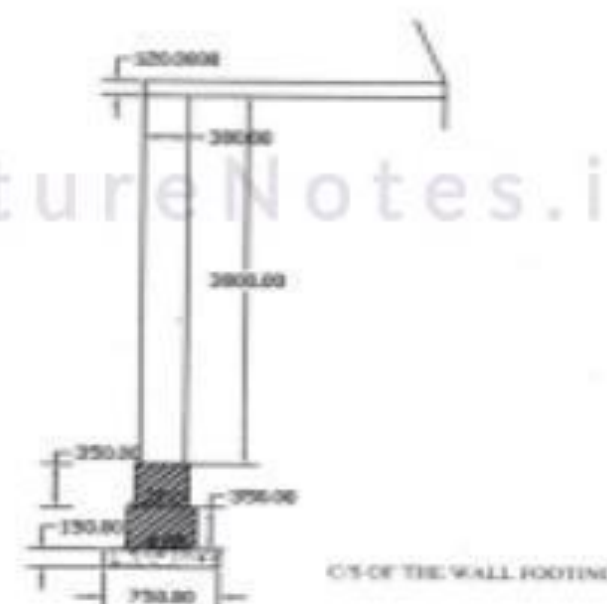

C/S OF THE WALL FOOTING

S.No.	Particulars of Items	No.	L	B	H	Q	Explanation
	The quantities of various items of the building for the Ground floor is same as previous problem. Here the quantities of various items of the building for the First floor is mentioned here.						
	<u>First Floor</u>						
1	R.C.C.(1:1.5:3) for						
	a) Columns	8	0.3	0.30	3.0	2.16	
	b) Slabs	1	7.40	8.4	0.15	9.324	
	c) beams	1	40.7	0.3	0.3	3.663	
	d) lintels over doors	1	1.2	0.3	0.1	0.036	
	windows	6	1.4	0.3	0.1	0.252	
						Total	15.435 m³
2.	B.M. with CM(1:8) in the first floor	1	28.6	0.3	3.0	25.74	
	Parapet wall	1	30.4	0.3	0.6	5.47	
	Deductions for openings						
	Doors	1	1.0	0.3	2.0	-0.6	
	Windows	6	1.2	0.3	1.5	-3.24	
	Net BM					= 25.74+5.47-0.6-3.24 =	27.372 m³
3.	Plastering with CM(1:4)						
	for walls	1x2	30.4	--	3.0	182.4	
	for parapet wall sides	1x2	30.4	--	0.6	36.48	
	Parapet wall Top	1	30.4	0.3	--	9.12	
	Deductions						
	Doors	1	1.0	---	2.0	-2.0	
	Windows	6	1.2	--	1.5	-10.8	
						Total	215.2 m²
4.	Flooring with CM(1:3)	1	6.8	7.8	---	53.04	m ²
5.	Plastering for ceiling with CM(1:3)= Same as Flooring					53.04	m ²
6.	White washing or colour washing = same as ceiling & BM						
	= 53.04 + 215.2 = 268.24						m²
7.	The estimation of a staircase is mentioned separately in the next problem						

Example 6: - Estimate the Quantities of the pictured roof shown in figure

- Size of common rafter = 80x40mm
- Size of ridge piece = 120x 200mm
- Size of eaves board = 20 x 300mm

230mm thick brick wall

Common rafters at 450mm c/c

LectureNotes.in



Rise = 1/3Span

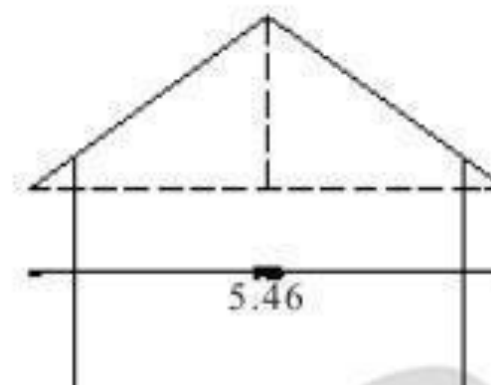

$$\text{a) Length of Common rafter} = \sqrt{\left(\frac{\text{length}}{2}\right)^2 + \left(\frac{\text{Span}}{3}\right)^2} = \sqrt{2.73^2 + \left(\frac{5.46}{3}\right)^2}$$

$$= 3.28\text{m}$$

$$\text{b) Length of ridge piece} = 7.0 + 0.23 \times 2 + 0.5 \times 2 = 8.46 \text{ m}$$

$$\text{c) Length of Eaves board} = 2(8.46 + 5.46) = 27.84\text{m}$$

S.No	Description	No	L	B	H	Qty	Remarks
1	Ridge piece	1	8.46	0.12	0.20	0.20	
2	Eaves Board	1	27.84	—	0.30	8.35	Unit of eaves Board in m ²
3	Common rafters	40	3.28	0.08	0.04	0.42	

LectureNotes.in

Example- 7: - Calculate the quantities of items of the stair case of the figure shown in below.

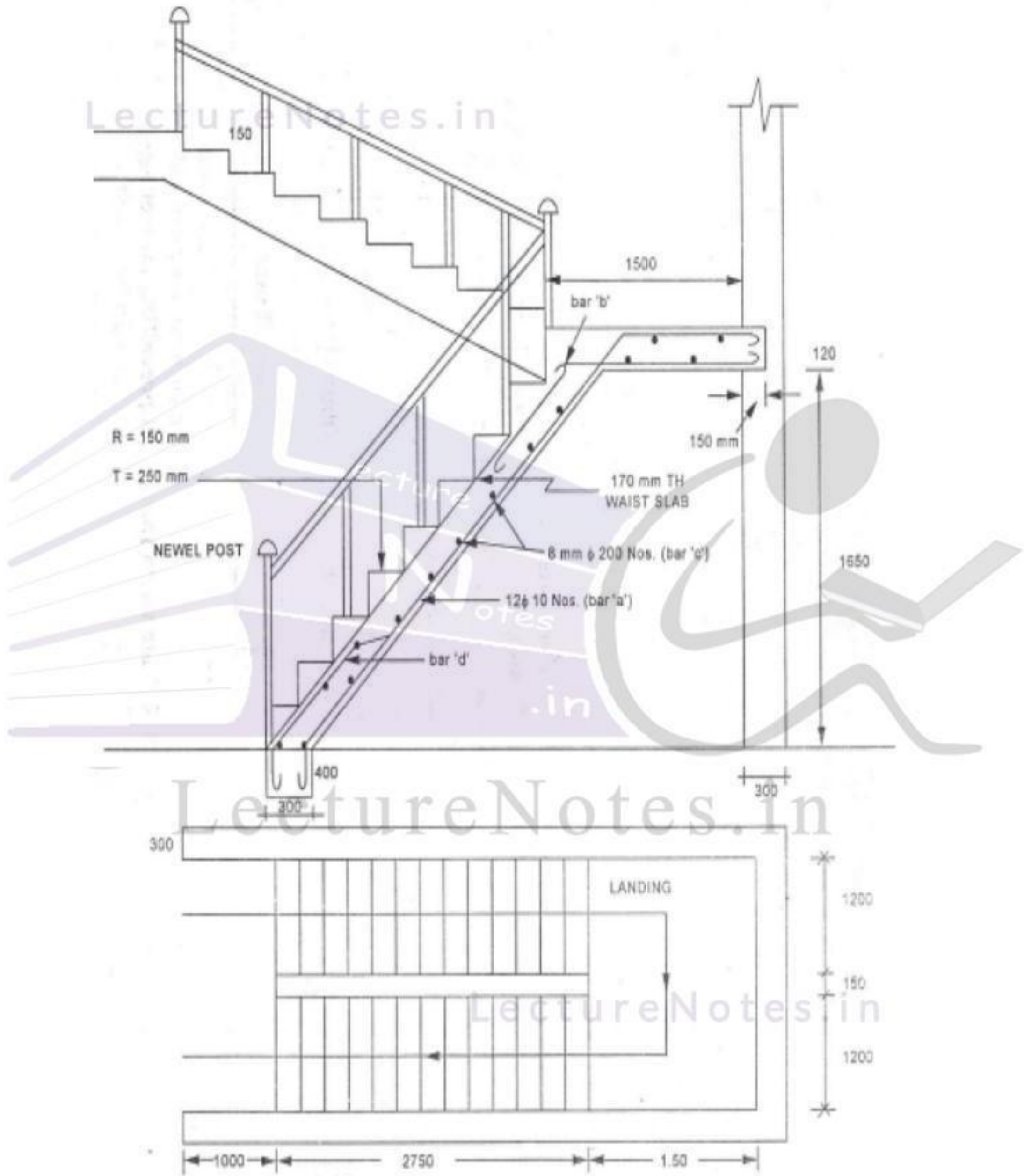
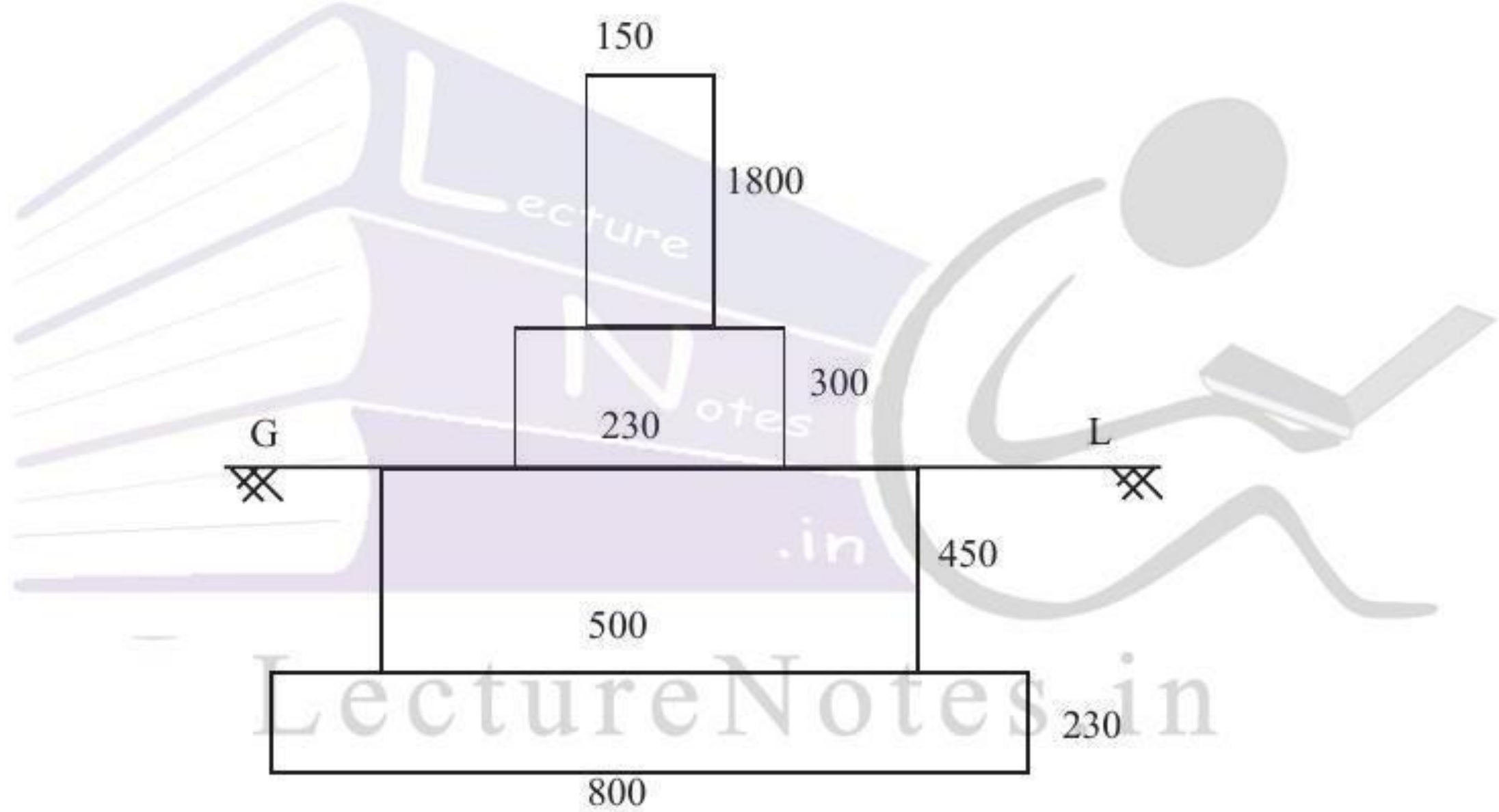
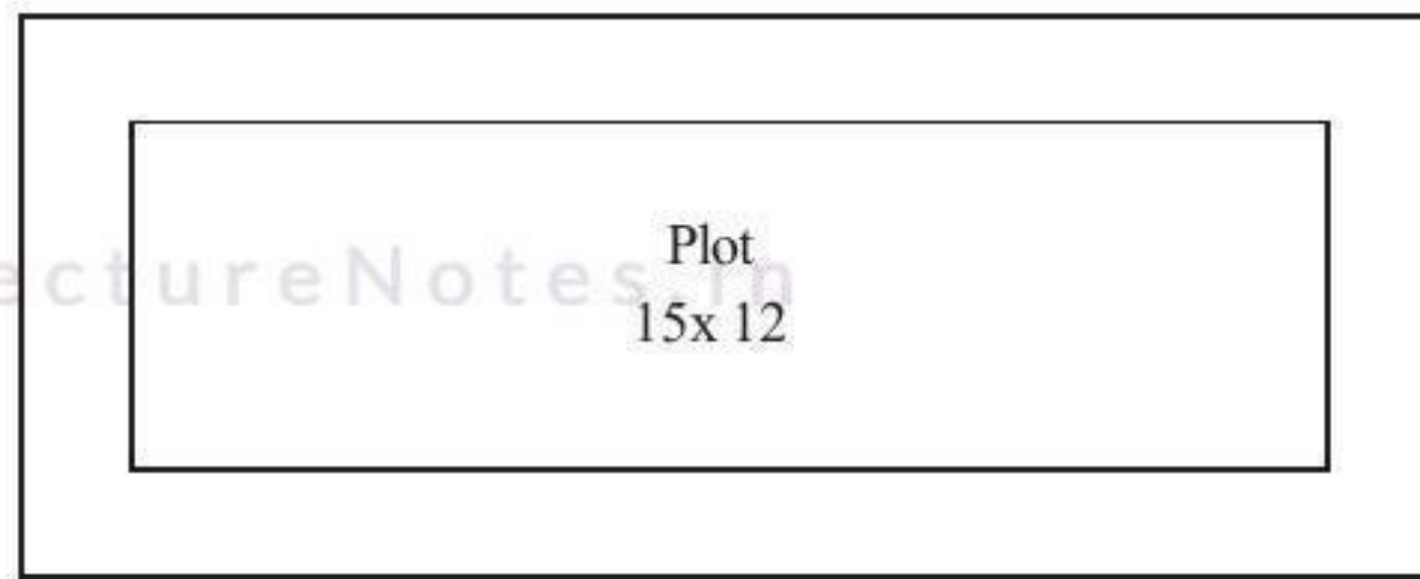

Fig. 4.12

R.C.C. Stair Case

S.No.	Particulars of Items	No.	L	B	H	Q	Explanation
1	R.C.C.(1:2:4)excluding steel and its fabrication but including centering and shultering and binding wire.						
	a) Toe wall	1x1	3.15	0.3	0.4	0.38	m³ L=(1.2+0.15+1.2+2x0.3)
	b) Waist slab for 1 and II flights	1x2	3.21	1.2	0.17	1.31	L = $\sqrt{2.75^2 + 1.65^2} = 3.21m$
	c) Landing Middle and first floor	1x2	2.85	1.65	0.17	1.60	L=(1.2+0.15+1.2+2x0.15)
					Total	3.29	m³
2.	Ist class brick work in C.M. (1:4) for steps	2x11	1.2	$\frac{1}{2}x(0.25+1.5)$		0.495	
3.	20mm. thick cement plastering (1:5) for steps finished neat						
	a) Treads & Rises	2x11	1.2	$x(0.25+0.15)$		10.56	
	b) ends of steps	2x11		$\frac{1}{2}x(0.25+1.5)$		0.41	
					Total	10.97	m²
4.	2.5cm No sing in steps	2x12	1.2	--	--	28.8	M
5.	2.5cm. C.C. flooring finished neat cement floating in middle and first floor landing.	1x2	2.55	1.2	--	6.12	m²
6.	Supplying and fixing of best teak wood hand rail finished smooth	1x1	6.67	--	--	6.67	M
7.	supply and fixing of best teak wood newel posts & finished smooth	1x2	1.0	0.1	0.1	0.02	m³
8.	Cap of Newel post	1x2	---	--	---	2Nos.	

Example 8:- From the given figure below calculate the details estimate for the Compound Wall



Cross Section of the compound wall

- Note: 1) Brick Pillers of size 230x 230 size are built every 3 meters
2) The expansion joints are provided for every 6m length

S.No.	Particulars of Items	No.	L	B	H	Q	Explanation
1	Earth work excavation for foundation 15.15 12.15 Total Centerline length= 2(15.15+12.15)=54.6	1	54.6	0.80	0.68	29.7	m ³
2.	C.C.(1:4:8) for foundation	1	54.6	0.80	0.23	10.04	m ³
3.	First class brick work in CM(1:6) in foundation						
	a) footing	1	54.6	0.5	0.45	12.28	
	b) Basement	1	54.6	0.23	0.3	3.76	
					Total	16.04	m ³
4.	D.P.C.with C.C.(1:1½:3) 25mmth	1	54.6	0.23	---	12.56	m ²
5.	a) First Class B.M. in CM(1:6) for wall in super structure	1	54.6	0.15	1.8	14.74	
	b) Brick pillar @3cm c/c	14	0.23	0.23	1.8	1.33	
	Deduction 150mm th	14	0.15	0.23	1.8	-0.87	
	wall				Total	15.2	m ³
6.	Plastering with CM(1:5)						
	a) Outer surface & inner surface (0.3+0.04+1.8)	1x2	54.6	---	2.14	233.69	
	b) Top of wall	1x1	54.6	0.15	--	8.19	
	c) Piller Projection from the face of the wall	14x2	0.04	---	1.8	2.016	
					Total	243.89	m ²
7.	White washing/colour same as item(6)					243.89	m ²

Example 9:- Estimation of basement steps (one way)

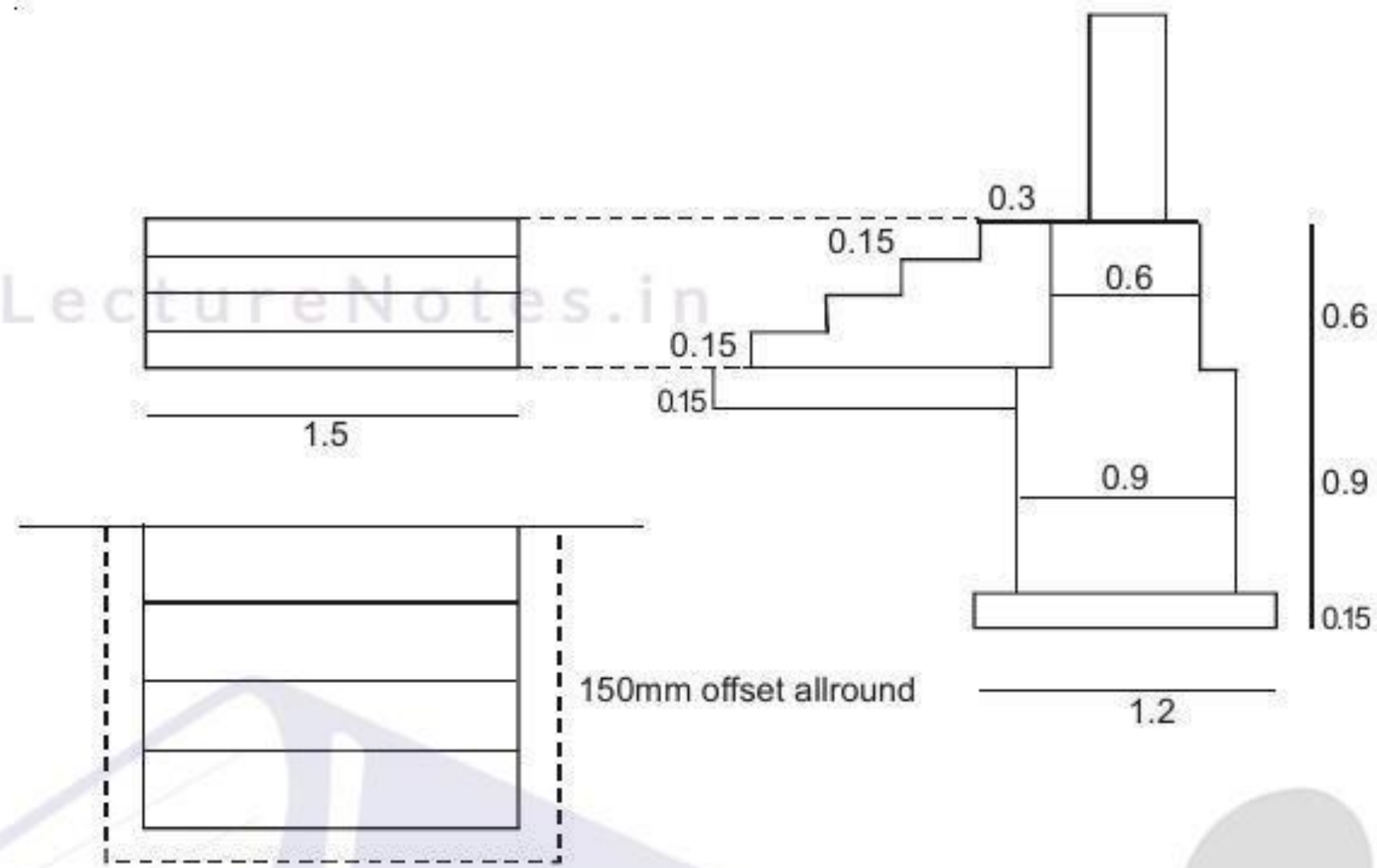

Note: All dimensions are in metres

S.No.	Particulars of Items	No.	L	B	H	Q	Explanation
1	Earth work excavation for foundation	1	1.8	1.35	0.15	0.360	m ³
2.	C.C.(1:4:8) bed for foundation	1	1.8	1.35	0.15	0.360	m ³
3.	Ist class BM in CM(1:4)						
	a) 1st step	1	1.5	1.20	0.15	0.27	
	b) 2nd Step	1	1.5	0.90	0.15	0.27	
	c) 3rd Step	1	1.5	0.60	0.15	0.13	
	d) 4th step	1	1.5	0.30	0.15	0.06	
					Total	0.73	m ³
4.	Plastering with CM(1:3)						
	a) Threads	4	1.5	---	---	1.8	
	b) Risers	4	1.5	---	0.15	0.9	
	c) ends						
	a) 1st step	2	1.2	---	0.15	0.36	
	b) 2nd Step	2	0.9	---	0.15	0.27	
	c) 3rd Step	2	0.6	---	0.15	0.18	
	d) 4th Step	2	0.3	---	0.15	0.09	
					Total	3.60	m ²
5.	white washing/colour washing = Same as item (4)					3.60	m ²

EXERCISE**Short Answer Questions**

- The internal dimensions of a single roomed building are 5.75x3.75m. Find the Centre line length of room and parapet. If the wall thickness of room and parapet are 300mm and 250mm respectively.
- The internal dimensions of a room are 6.25 x 4.25m. find the quantity of sand filling in basemet. the height and thickness of basement are 750mm and 450mm respectively the wall thickness of room is 230mm.

Essay Type Questions:

- The plan and section of one roomed building

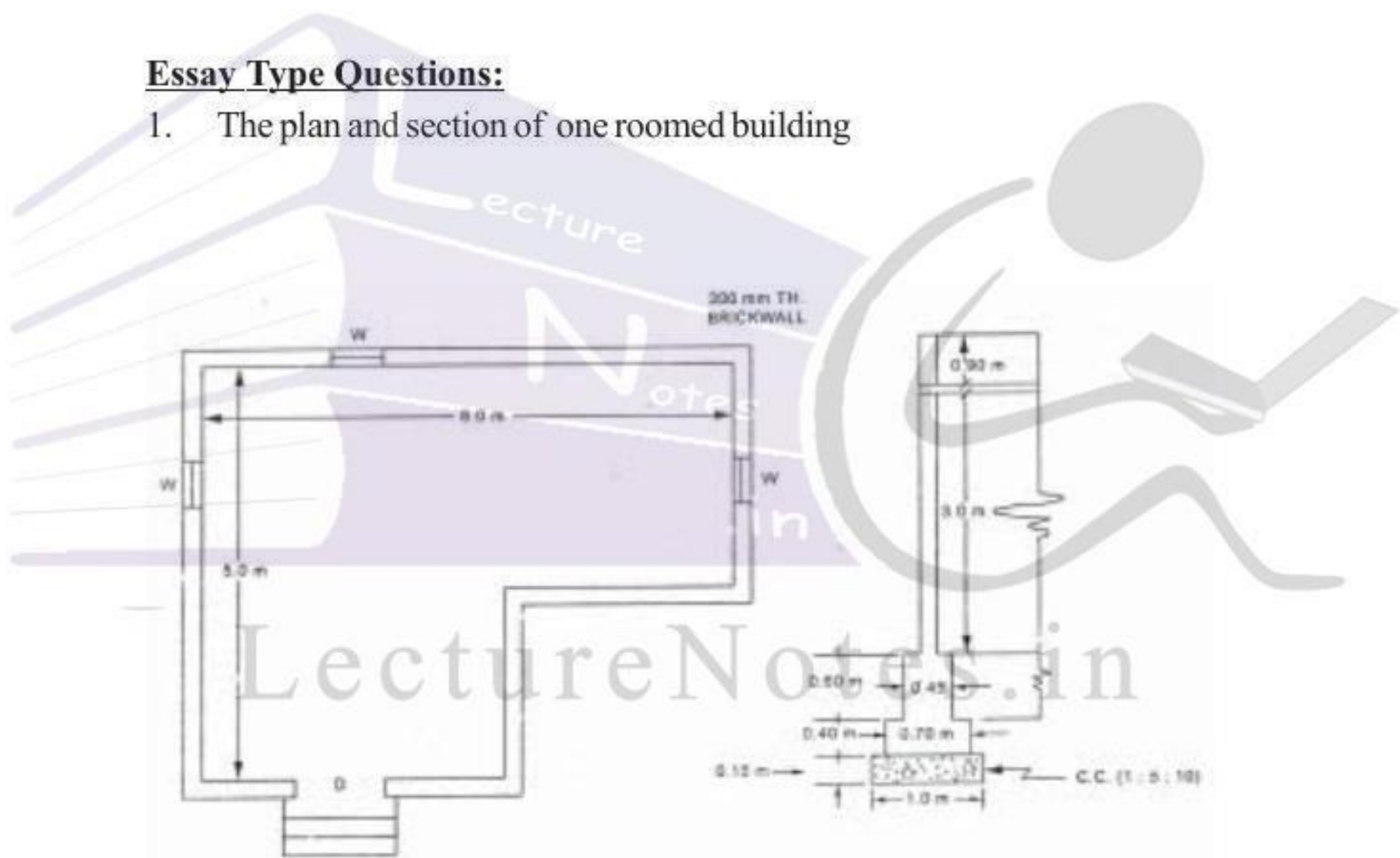

Calculate the following quantities by a) central line method b) Long wall & shortwall method.

- Earth work excavation .
- Cement Concrete for foundation.
- Brick in CM 1:6 for footing.
- Brick in CM 1:6 for walls excluding openings

- 2) For a building drawing shown in figure calculate
- Brickwork in CM(1:6) in foundation footing.
 - 12mm thick plastering the wall surfaces with CM (1:6) for all super structure walls by central line method.
 - Earth work excavation for the foundation.

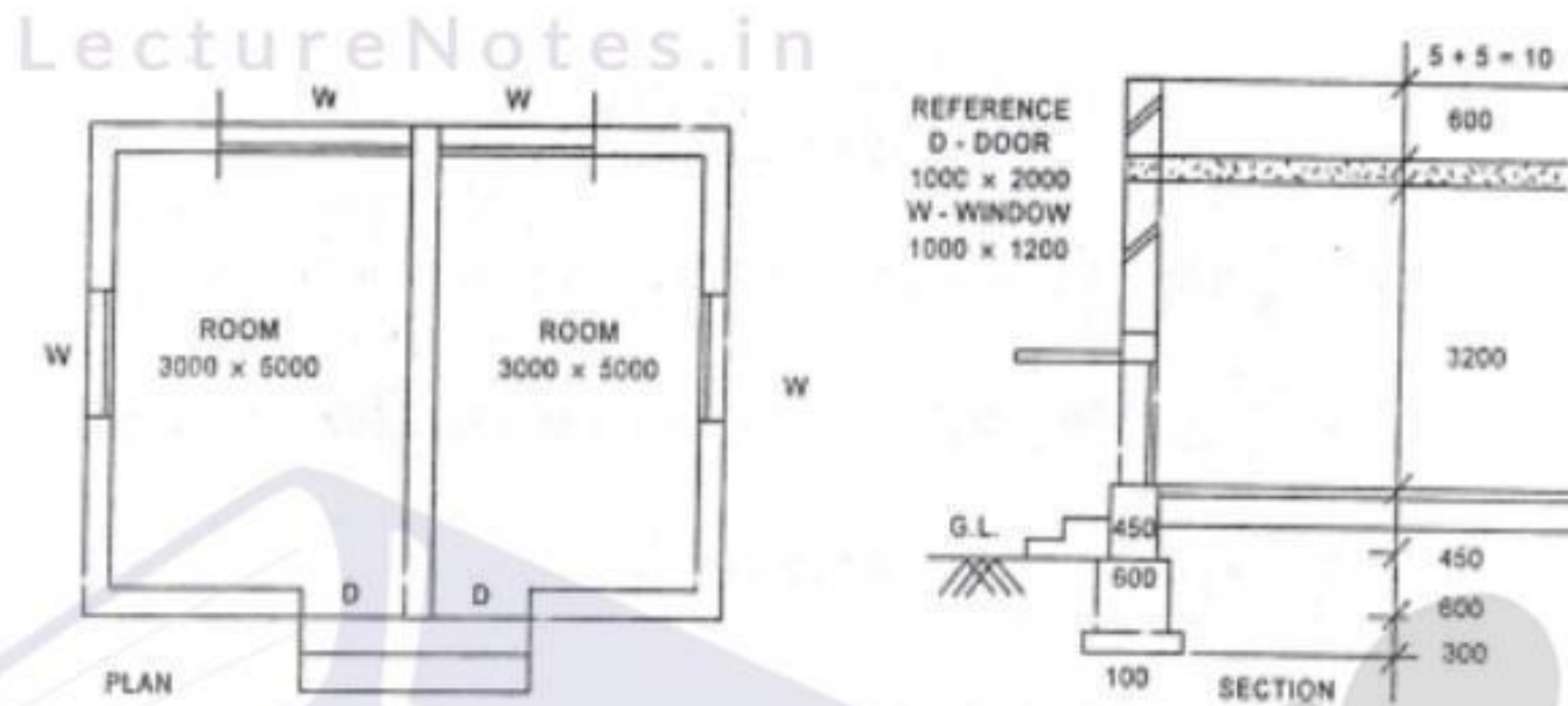

- 3) Prepare the detailed estimate for the following items of work for the building shown in figure.

- R.C.C. (1:1.5:3) in columns upto ground level only.
- R.C.C. (1:2:4) in plinth Beams
- R.C.C. (1:2:4) in slab.

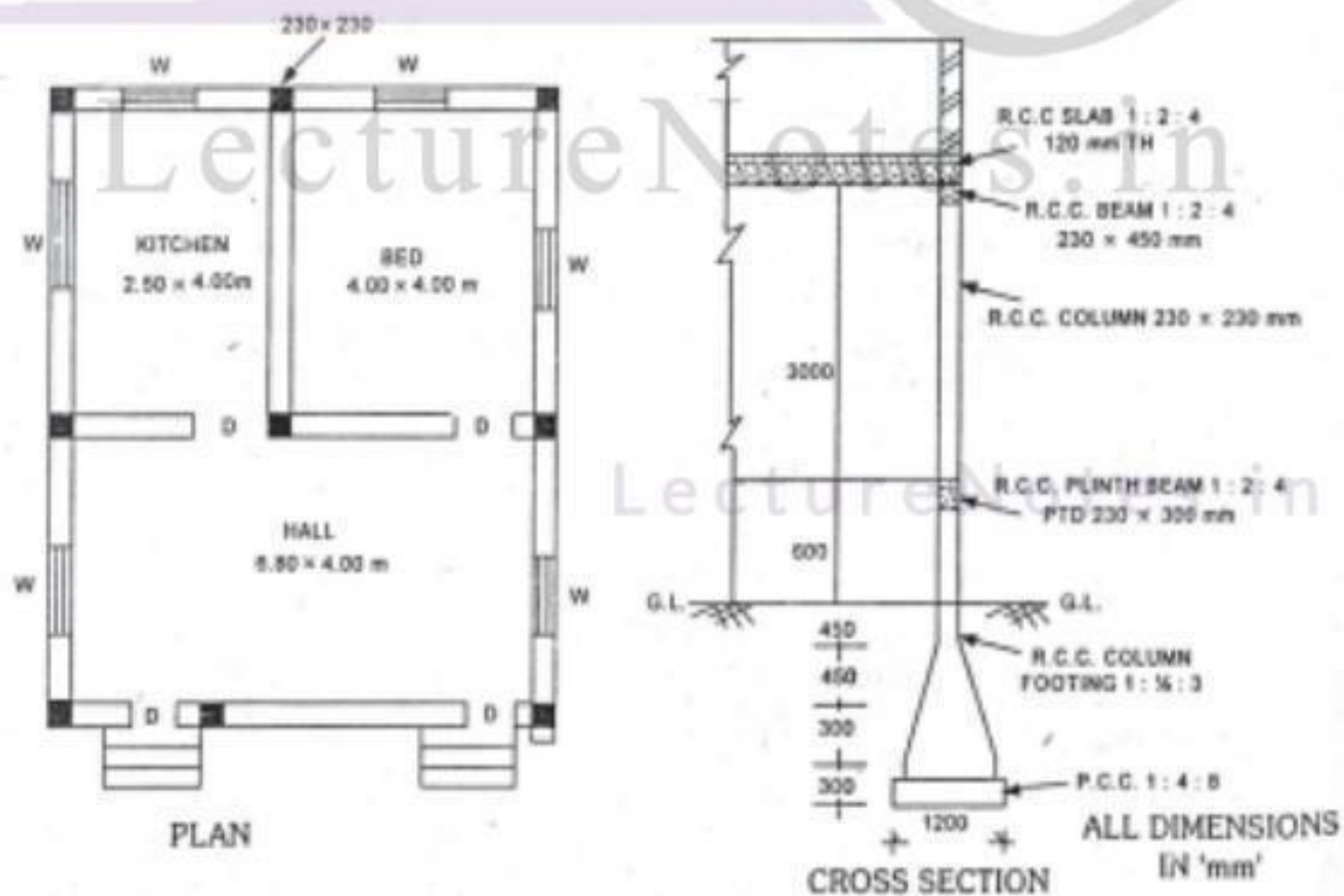

- 4) Prepare the detailed estimate for the following items of work for a building shown.
- R.R. masonry in CM 1:6 for footings and basement.
 - Brick work in CM 1:6 for super structure.
 - Plastering for ceiling with CM 1:3

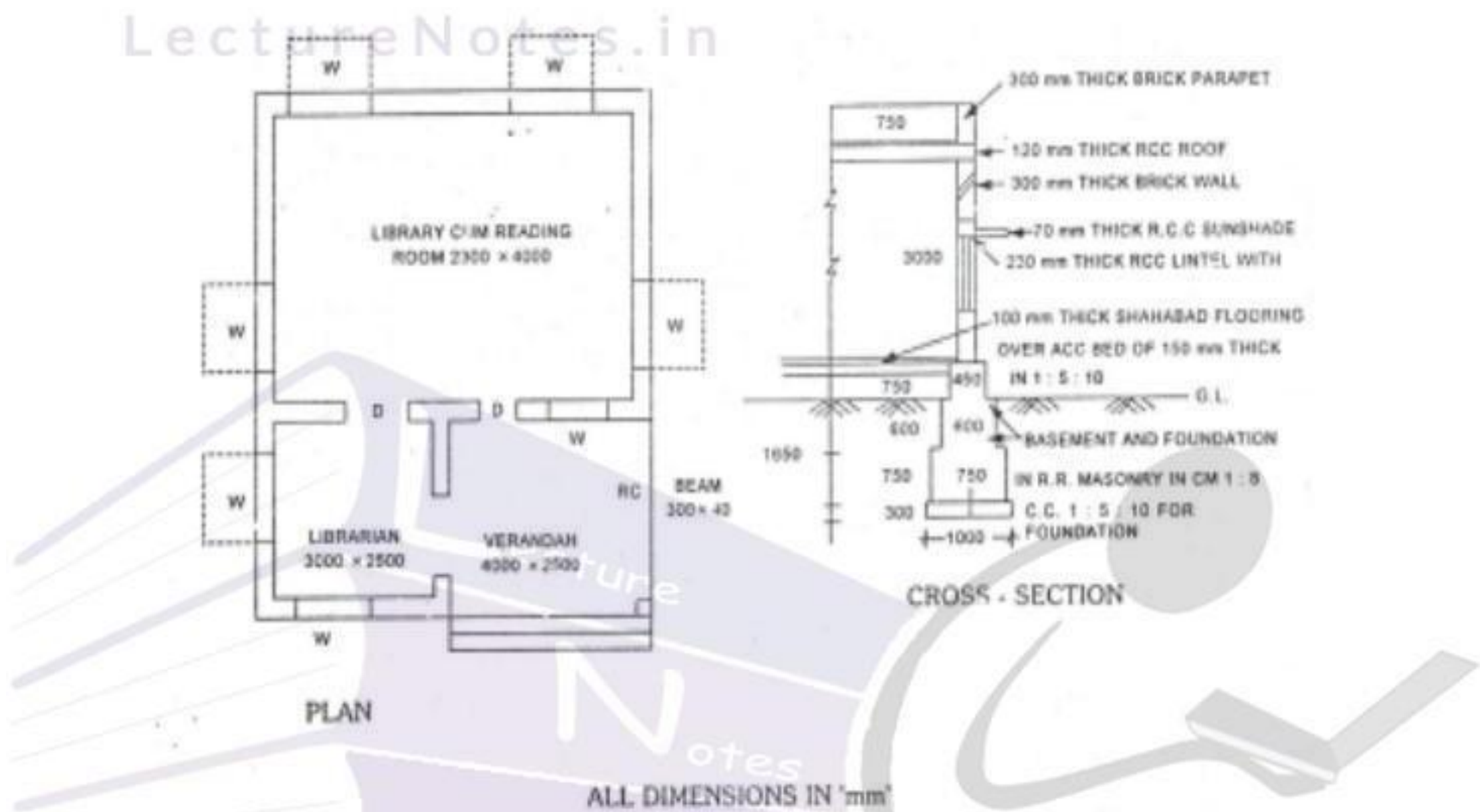

- 5) From the Hipped roof shown in sketch, calculate
- Length of Hip rafter
 - Ridge Piece

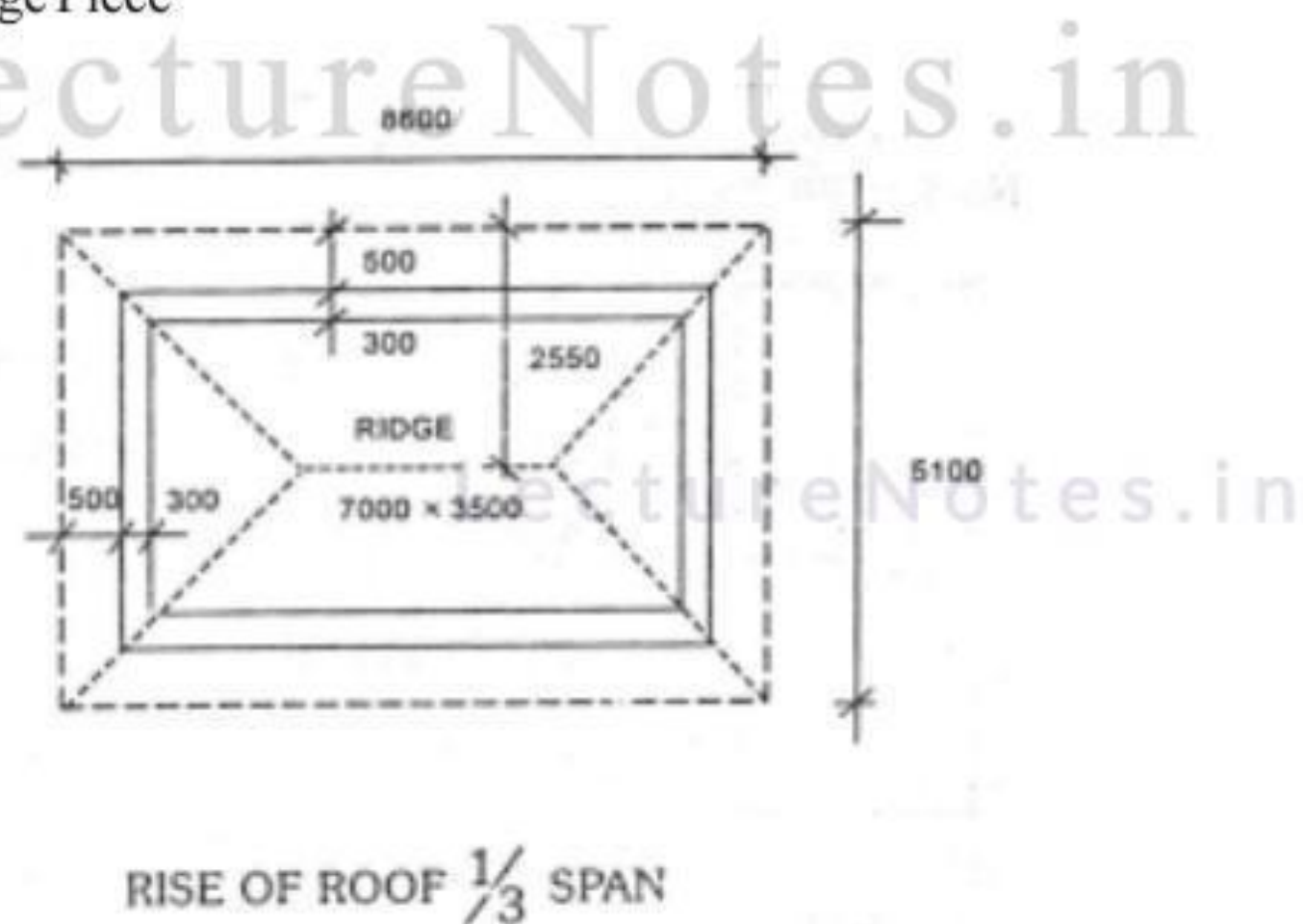

- 6) For an R.C.C. Stair case shown in fig. Calculate the following contents.
- a) R.C.C. (1:2:4) for base beam, waist slab, Top and intermediate landings.
 - b) Brick work in CM(1:4) for steps.

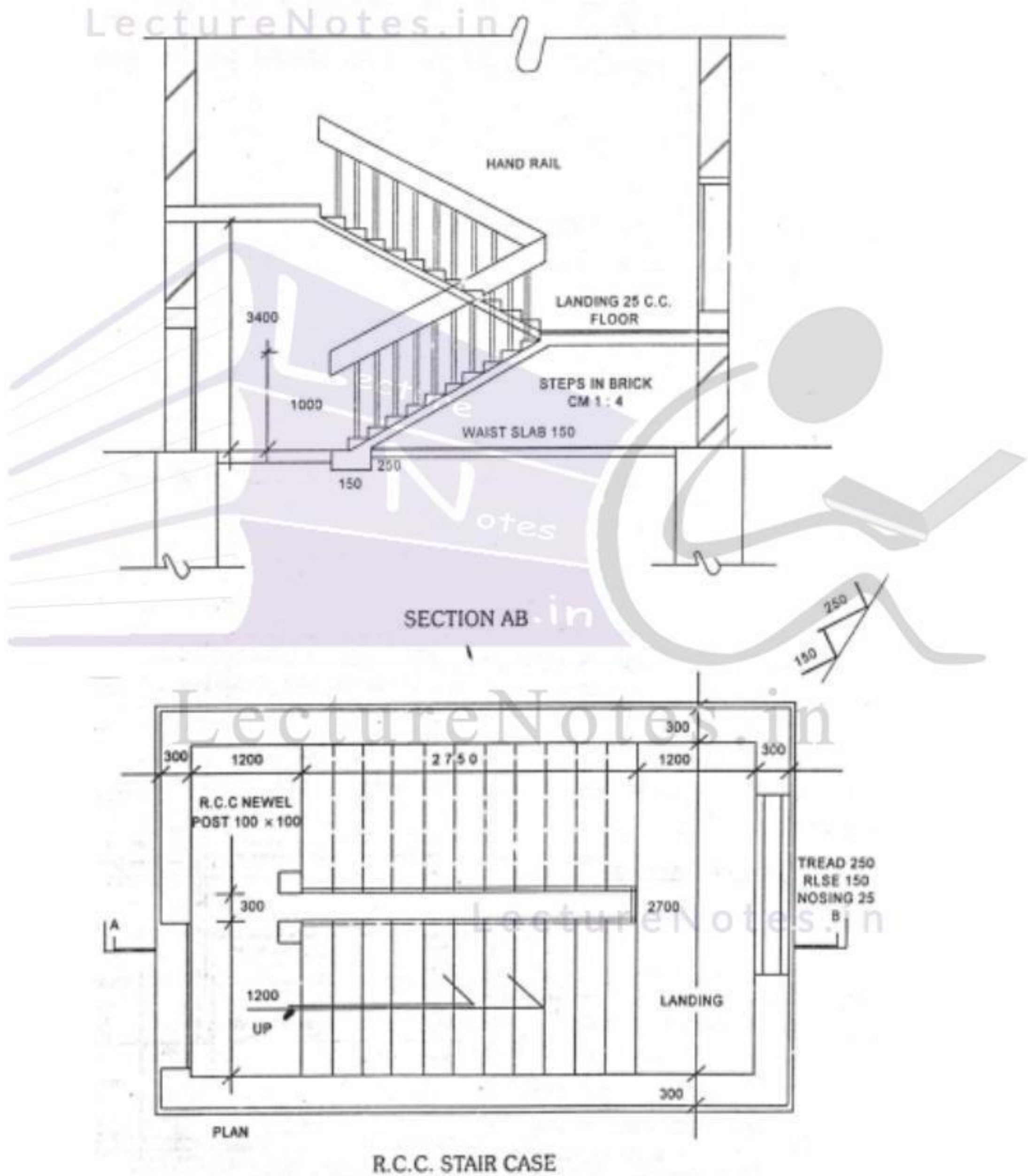

- 7) The section of steps at the front of a residential building is shown in fig. Calculate
- Volume of BM in CM (1:5) for all three steps. the length of steps is 2.1m
 - Plastering with CM (1:4) for all three steps.

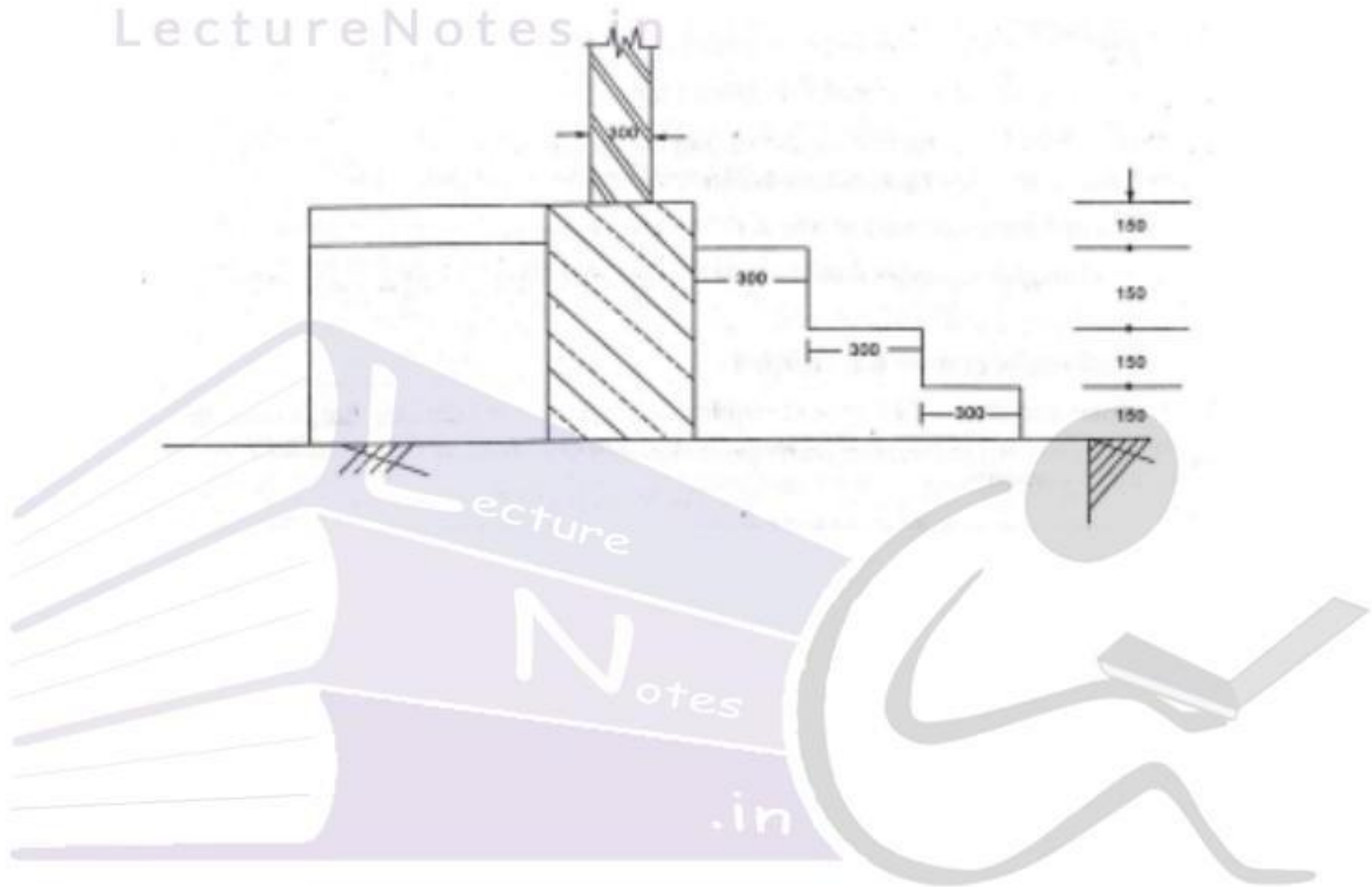

LectureNotes.in

LectureNotes.in

ANALYSIS OF RATES

Definition : In order to determine the rate of a particular item, the factors affecting the rate of that item are studied carefully and then finally a rate is decided for that item. This process of determining the rates of an item is termed as analysis of rates or rate analysis.

The rates of particular item of work depends on the following.

1. Specifications of works and material about their quality, proportion and constructional operation method.
2. Quantity of materials and their costs.
3. Cost of labours and their wages.
4. Location of site of work and the distances from source and conveyance charges.
5. Overhead and establishment charges
6. Profit

Cost of materials at source and at site of construction.

The costs of materials are taken as delivered at site inclusive of the transport local taxes and other charges.

Purpose of Analysis of rates:

1. To work out the actual cost of per unit of the items.
2. To work out the economical use of materials and processes in completing the particulars item.
3. To work out the cost of extra items which are not provided in the contract bond, but are to be done as per the directions of the department.
4. To revise the schedule of rates due to increase in the cost of material and labour or due to change in technique.

Cost of labour -types of labour, standard schedule of rates

The labour can be classified in to

- 1) Skilled 1st class
- 2) Skilled IInd Class
- 3) unskilled

The labour charges can be obtained from the standard schedule of rates 30% of the skilled labour provided in the data may be taken as Ist class, remaining 70% as II class. The rates of materials for Government works are fixed by

the superintendent Engineer for his circle every year and approved by the Board of Chief Engineers. These rates are incorporated in the standard schedule of rates.

Lead statement: The distance between the source of availability of material and construction site is known as "Lead" and is expected in Km. The cost of conveyance of material depends on lead.

This statement will give the total cost of materials per unit item. It includes first cost, conveyance loading, unloading stacking, charges etc.

The rate shown in the lead statement are for metalled road and include loading and staking charges. The environment lead on the metalled roads are arrived by multiplying by a factor

- | | | | |
|----|-------------------|---|------------|
| a) | for metal tracks | - | lead x 1.0 |
| b) | For cartze tracks | - | Lead x 1.1 |
| c) | For Sandy tracks | - | lead x 1.4 |

Note: For 1m³ wet concrete = 1.52m³ dry concrete approximately
 SP.Wt of concrete = 1440 kg/m³ (or) 1.44 t/m³
 1 bag of cement = 50 Kg

Example 1:- Calculate the Quantity of material for the following items.

- R.C.C. (1:2:4) for 20m³ of work
- R.C.C. (1:3:6) for 15m³ of work

$$\text{a) Quantity of cement required} = \frac{1}{(1+2+4)} \times 1.52 \times 20 = 4.14\text{m}^3 \times \frac{1440}{50} = 119.26 \text{ bags}$$

$$\text{Quantity of Sand required} = \frac{2}{(1+2+4)} \times 1.52 \times 20 = 8.28\text{m}^3$$

$$\text{Quantity of course aggregate} = \frac{4}{7} \times 1.52 \times 20 = 16.56\text{m}^3$$

$$\text{b) Quantity of cement required} = \frac{1}{10} \times 1.52 \times 15 = 2.28\text{m}^3 \times \frac{1440}{50} = 65.66 \text{ Bags}$$

$$\text{Quantity of sand required} = \frac{3}{10} \times 1.52 \times 15 = 6.84\text{m}^3$$

$$\text{Quantity of CA required} = \frac{6}{10} \times 1.52 \times 15 = 13.68\text{m}^3$$

Example 2:- Calculate the quantity of materials for the following items.

a) C.M. (1:4) for 1m³ of work

b) CM (1:6) for 1m³ of work

Hint: Cement will go to fill up the voids in sand. So total volume was be 4 instead of 1+4=5

a) Quantity of Cement required = $\frac{1}{4} \times 1 = 0.25\text{m}^3 = 0.25 \times \frac{1440}{50} = 7.2 \text{ bags}$

Quantity of Sand required = $\frac{4}{4} \times 1 = 1\text{m}^3$

b) Quantity of cement required = $\frac{1}{6} \times 1 = 0.16\text{m}^3 = 0.16 \times \frac{1440}{50} = 4.8\text{bags}$

Quantity of sand required = $\frac{6}{6} \times 1 = 1\text{m}^3$

Example 3:- Calculate the Quantity of Cement required in bags for the following items.

a) B.M. in CM(1:3) for 15 cum of work using 0.2m³ of CM required for 1m³ of Brick work

b) RCC (1:2:4) for 20m³ of work

Sol : a) 1m³ of Brick work - 0.2m³ of CM(1:3)

15 m³ of Brick work = 15 × 0.2 = 3m³

Quantity of cement required in bags = $\frac{1}{3} \times 3 \times \frac{1440}{50} = 28.8\text{bags}$

b) Quantity of Cement required in bags = $\frac{1}{7} \times 1.52 \times 20 \times \frac{1440}{50} = 125 \text{ bags}$

Example 4:- Calculate the quantity of Cement required in bags for the following items of

work.

a) C.C. (1:4:8) usy 40mm HBG metals for 30m³ of work

b) RR masanry in CM(1:5) very 0.34m³ of CM for 1m³ of masanry for 20m of work

sol : a) Quantity of Cement required = $\frac{1}{13} \times 1.52 \times 30 \times \frac{1440}{50} = 101\text{bags}$

b) 1m³ of RR masanry = 0.34m³ of CM (1:5)

20 m³ of RR masanry required = ? 20 × 0.34 = 6.8m³

Quantity of cement required = $\frac{1}{5} \times 6.8 \times \frac{1440}{50} = 39.2\text{bags}$

Example 5: - Prepare the lead statement for the following materials

S.No.	Material	Rate at Source	Lead in KM			Conveyance Charge per km
			MT	CT	ST	
1.	40mm HBG Metal	Rs.120/m ³	---	5	7	Rs.5.00/m ³
2.	River Sand	Rs.15/m ³	3	2	6	Rs.3.50/m ³
3.	Cement	Rs. 135/bags	2	---	4	Rs. 4.00 per 4km/bag

S.No.	Material	Rate of Source	Lead in KM			Equalant lead in km	Conveyance Charge	Total conveyance Charge	Total cost
			MT	CT	ST				
1.	40mm HBG Metal	Rs.120/m ³	---	5	7	5×1.1+7×1.4=153	5.00/m ³	15.3×5=76.5	120+76.5=196.5/m ³
2.	River Sand	Rs.15/m ³	3	2	6	3×1+2×1.1+6×1.4=13.6	3.50/m ³	13.6×3.5=47.6	15+47.6=62.6/m ³
3.	Cement	Rs. 135/bags	2	---	4	2×1+4×1.4=7.6	4.00per4km/bag	$\frac{7.6}{4.0} \times 4.0 = 7.6$	135+7.6=142.6/bag

Cost of cement at site = 142.6/bag

1 bag of cement = 50kg

sp.wt of cement = $1440 \text{ kg/m}^3 = 1.44\text{t/m}^3$

Cost of Cement = $142.6 \times \frac{1440}{50} = 4106.88/\text{m}^3$

Example 6:- Prepare the lead statement for the following materials

S.No.	Material	Rate of Source	Lead in KM			Conveyance Charge per km	Seinorage Charges	Cess Charges
			ST	CT	MT			
1.	Cement	Rs.2100/10KN (tom)	5	2	3	Rs.1.5/m ³	---	---
2.	Bricks	Rs.850/100nos	5	--	3	Rs.30/1000Nos/Km	35	13
3.	Sand	Rs. 15/m ³	4	2	5	Rs.9.00 / km/cum	30	12
4.	40mm HBG Metal	Rs. 250/m ³	3	2	2	Rs.6.50/Km/m ³	35	15

S.No	Material	Rate of Source	Lead in KM			Equalant lead in km	Conveyance Charge Rs.	Total conveyance Charge Rs.	Seinorage Charge Rs.	Cess Charge Rs.	Total cost Rs.
			ST	CT	MT						
1.	Cement	Rs2100/10KN	5	2	3	5x1.4+2x1.1+3x1=11.2	1.50	16.80	--	2116.8/10KN	
2.	Bricks	Rs.850/1000nos	5	--	3	5x1.4+3x1=10	30	300.00	35	1198/1000nos	
3.	Sand	Rs. 15m ³	1	2	2	1x1.4+2x1.1+2x1=5.6	9.00/m ³	50.40	30	107.4/m ³	
4.	40mmHBG Metal	Rs.250/m ³	3	2	2	3x1.4+2x1.1+2x1=8.4	6.5/m ³	54.6	35	354.6/m ³	

Example 7:- Prepare a data sheet & calculate the cost of the following items of works:

- a) Plastering with cement mortar (1:4), 20 mm thick unit-10m²
 0.21m³ C.M. (1:4)
 0.66 Nos. Brick layer I class
 1.54 Nos. Brick layer II Class
 0.5 No.s Men Mazdoors
 3.2 Nos. Women mazdoors
 L.S. Sundries.
- b) R.R. Masonry in C.M. (1:6) -1m³
 1.1 m³ Rough stones
 0.34 m³ C.M. (1:6)
 0.54 No.s Mason I Class
 1.26 Nos. Mason II Class
 1.40 Nos. Men mazdoors
 1.40 Nos. Women mazdoors
 L.S. Sundries.

Lead Statement of materials:

S.No.	Materials	Cost at Source Rs. -- Ps.	Per	Lead in Km	Conveyance Charges per km
1	Rough stone	260=00	m ³	18	5=00/m ³
2	Sand	12=00	m ³	25	4=00/m ³
3	Cement	2100=00	10kn or 1tonne	Local	-

Labour Charges :

- Mason / Brick layer I Class Rs. 100=00 per day.
- Mason / Brick layer II class Rs. 80=00 per day
- Men mazdoor Rs. 60=00 per day
- Women mazdoor Rs. 60=00 per day
- Mixing charges of cement mortar Rs. 16=00perm³

Lead Statement :

S.No.	Material	Cost at Source	Per	Lead in KM	Conveyance Charge Rs.	Total conveyance Charge Rs.	Total cost Rs.
1	Rough Stone	260.00	m ³	18	500/m ³	90.00	350.00
2	sand	12.00	m ³	25	4.00/m ³	100.00	112.00
3	Cement	2100	10KN or 1tonne	Local	---	---	2100/tonne

a) Plaster with CM (1:4), 20mm thick, unit-10m²

Cost of CM (1:4) for 0.21m³

$$\text{cost of Cement} = \left(\frac{1}{4} \times 0.21 \times 1.44 \right) \times 2100 = 158.76$$

$$\text{Cost of Sand} = \left(\frac{4}{4} \times 0.21 \right) \times 112 = 23.52$$

$$\text{Total Cost Rs. } \underline{182.28}$$

S.No.	Description	Quantity	Unit	Rate	per	Amount
1	CM(1:4)	0.21	m ³	182.28	0.21m ³	182.28
2	Brick layer I class	0.66	Nos	100	day	66.00
3	Brick layer II Class	1.54	Nos	80	day	123.20
4	Men mazdoors	0.5	Nos	60	day	30.00
5	Women mazdoors	3.2	Nos	60	day	192.00
6	Mixing Charges	0.21	m ³	16	m ³	28.16
7.	Sundrys	L.S.				3.36

Total Rs. 625.00

b) RR Masanry in CM (1:6) -1m³

Cost of CM (1:6) for 0.34m³

$$\text{Cost of Cement} = \left(\frac{1}{6} \times 0.34 \times 1.44 \right) \times 2100 = 171.36$$

$$\text{Cost of Sand} = \left(\frac{6}{6} \times 0.34 \right) \times 112 = 38.08$$

$$\text{Total Cost Rs. } \underline{209.44}$$

S.No.	Description	Quantity	Unit	Rate	per	Amount
1	Rough Stone	1.1	m ³	350	m ³	385.00
2	CM(1:6)	0.34	m ³	209.44	0.34m ³	209.44
3	Mason I Class	0.54	Nos	100.00	day	54.00
4	Mason II Class	1.26	Nos	8.00	day	10.08
5	Men Mazdoors	1.40	Nos	60.00	day	84.00
6	Women Mazdoors	1.40	Nos	60.00	day	84.00
7	Mixing Charges	0.34	m ³	16.00	m ³	5.44
8	Sundries	L.S.				18.04

Total Rs. **850.00/m³**

Example 8:- Prepare a data sheet and calculate the cost of the items given below:

- a) Brick masonry in C.M. (1:6) with country bricks-unit 1cum.
 600Nos. country bricks.
 0.38m³ C.M.(1:6)
 1.40Nos. Mason
 0.7 Nos. Man Mazdoor
 2.1 Nos. Woman Mazdoor
 L.S. Sundries.
- b) C.C.(1:5:10) using 40mm HBG metal unit 1cum.
 0.92m³..... 40mm size HBG metal
 0.46m³..... Sand
 0.092m³..... Cement
 0.2 Nos Mason
 1.8 Nos Man Mazdoor
 1.4 Nos. Woman Mazdoor
 L.S. Sundries.
- Lead Statement of materials:

S.No.	Material	Cost at Source Rs. Ps.	Per	Lead in Km	Conveyance Charges per Km
1	40mm HBG metal	210=00	m ³	16	Rs.6=00/m ³
2	Sand	16=00	m ³	18	Rs.3=00/m ³
3	Bricks country	780=00	1000Nos	at site	--
4	Cement	2600=00	10KN or 1tonne	at site	--

Analysis of Rates

64

Labour charges:

- i) Mason- Rs. 90 per day.
- ii) Man Mazdoor - Rs. 70 per day
- iii) Woman Mazdoor - Rs. 70 per day.
- iv) Mixing Charges of C.M. Rs. 20=00 per m³.

Lead Statement :

Sl. No.	Material	Cost at Source	Per	Lead in KM	Conveyance Charge Rs.	Total conveyance Charge Rs.	Total cost Rs.
1	40mm HBG metal	210.00	m ³	16	Rs.6/m ³	96.00	306.00
2	sand	16.00	m ³	18	Rs.3/m ³	54.00	70.00
3	Country bricks	780.00	1000nos	at Site	---	---	780.00
4	Cement	2600	10kn or 1tonne	At site	---	---	2600/t

- a) B.M. CM(1:6) with country bricks - 1m³
CM (1:6) - 0.38m³

$$\text{Cost of Cement} = \left(\frac{1}{6} \times 0.38 \times 1.44 \right) \times 2600 = 237.12$$

$$\text{Cost of Sand} = \left(\frac{6}{6} \times 0.38 \right) \times 70 = 26.60$$

Total Cost Rs. 263.72

S.No.	Description	Quantity	Unit	Rate	per	Amount Rs.
1	Country Bricks	600	Nos	780	1000	769.23
2	CM (1:6)	0.38	m ³	263.72	0.38m ³	263.72
3	Mason	1.4	Nos	90	day	126.00
4	Man mazdoors	2.1	Nos	70	day	147.00
5	Mixing Charges	0.38	m ³	20	m ³	7.60
6	Sundries	L.S				86.44

Total Rs. 1400.00

b) CC (1:5:10) using 40mm HBG metal -1m³

S.No.	Description	Quantity	Unit	Rate	per	Amount
1	40mm HBG metal	0.92	m ³	306	m ³	281.52
2	Sand	0.46	m ³	70	m ³	32.20
3	Cement	0.092	m ³	2600	t	344.45
4	Mason	0.2	Nos	90	Nos	18.00
5	Man mazdoor	1.80	Nos	70	Nos	126.00
6	women Mazdoor	1.4	Nos	70	Nos	98.00
7	Mixing charges	1.0	m ³	20	m ³	20.00
8	Sun dries	L.S				4.83

Total Rs. 925.00/m³

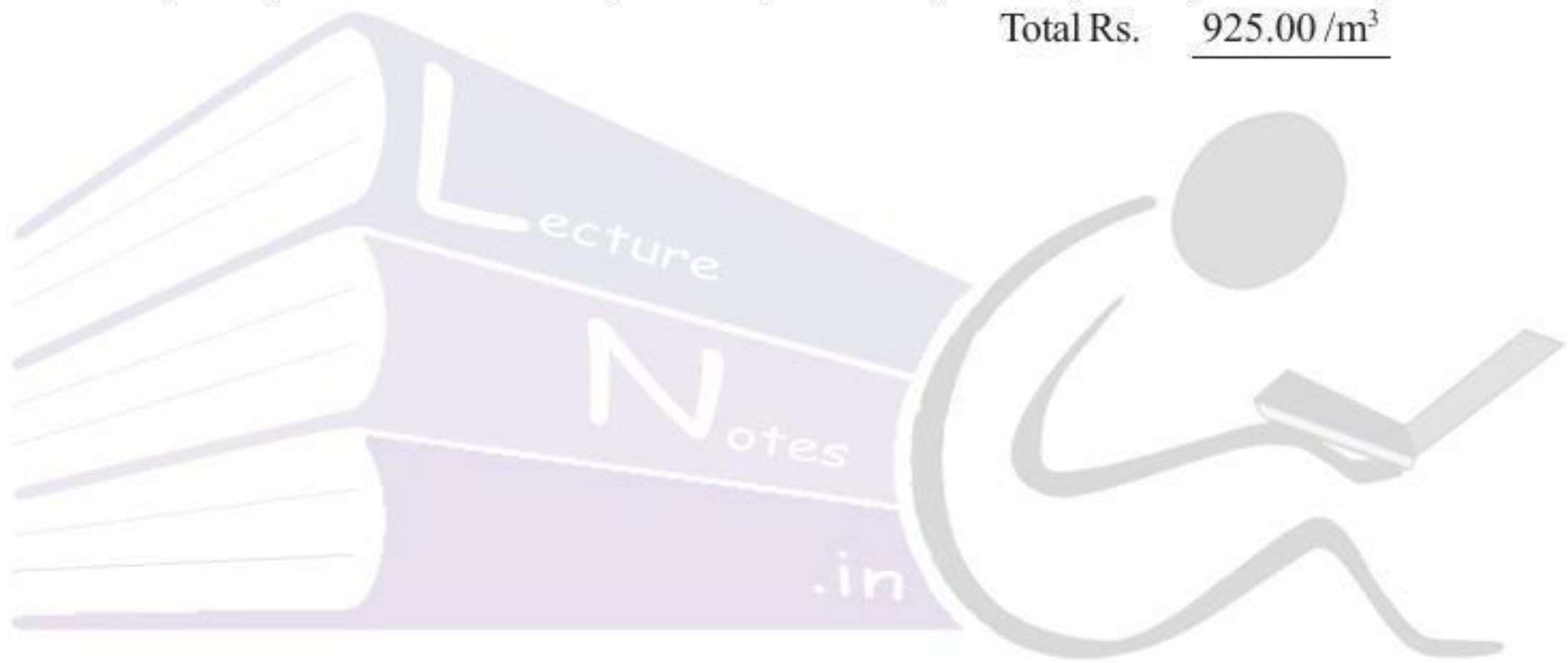

LectureNotes.in

LectureNotes.in

Lead Statement

Town data for Guntur Town Buildings as per 2004-05-"S.S.R.

Sl. No.	Description of Material	Source of supply	Unit	Lead in Km	Initial cost of material	Deduct Stacking charges	Convey-ance Charge	Blasting Charges	Seinorage Charges	Crushing charges	Total Cost
1	Cement	Local	Mt	0.00	2700.00	0.00	0.00	0.00	0.00	0.00	2700.00
2	Sand for Mortar	Krishna River	Cum	34KM	71.00	-3.70	181.50	0.00	36.00	0.00	284.80
3	Sand for Filling	T.lapalem Vagu	Cum	28km	28.00	-3.70	16.90	0.00	36.00	0.00	224.20
4	Gravel	Perecherla	Cum	12km	38.50	-3.70	110.20	0.00	20.00	0.00	165.00
5	40mm HBG metal	Lam	Cum	11km	269.00	-6.10	119.60	53.00	45.00	67.25	547.75
6	20mm HBG Metal	Lam	Cum	11km	469.00	-6.10	119.60	53.00	45.00	117.25	797.75
7	12mm HBG metal	km	Cum	11km	375.00	-6.10	119.60	53.00	45.00	93.75	680.25
8	10mm HBG metal	Lam	Cum	11km	313.00	-6.10	119.60	53.00	45.00	78.25	602.75
9	6mm HBG metal	Lam	Cum	11km	237.00	-6.10	119.60	53.00	45.00	59.25	507.75
10	R.T.Steel	Local	Mt	---	275.00	---	--	---	--	---	275.00
11	Bricks	Kollur	1000	48km	1250.00	-5.90	424.70	---	---	--	1668.80
12	R.R.Stone for masonry works	Perecherla	Cums	11km	107.00	-6.10	119.60	51.50	45.00	---	317.00

Preparation of Unit rates for finished items of works**I a) Cement Concrete in foundation (1:5:10)**

S.No.	Description of Item	Quantity	Unit	Rate	Per	Amount
1.	40mm HBG Metal	0.92	Cum	547.75	Cum	503.93
2.	Sand	0.46	cum	284.80	Cum	131.00
3.	Cement	0.092	Cum	2700.00	MT	357.70
4.	Mason Ist Class	0.06	No	150.00	Nos	9.00
5.	Mason 2nd Class	0.14	No	131.00	Nos	18.34
6.	Man mazdoor	1.80	No	101.00	Nos	181.80
7.	Women Mazdoor	1.40	No	101.00	Nos	141.40
8.	Add Extra 15%on M.L					52.58
						1395.75
9	Add T.O.T. @4%					55.83
10	Sundries					0.42
Total Rs.						1452.00

b). Cement Concrete in foundation (1:4:8)

S.No.	Description of Item	Quantity	Unit	Rate	Per	Amount
1.	40mm HBG Metal	0.92	Cum	547.75	Cum	503.93
2.	Sand	0.46	Cum	284.80	Cum	131.00
3.	Cement	0.115	Cum	2700.00	MT	447.12
4.	Mason Ist Class	0.06	No	150.00	Nos	9.00
5.	Mason 2nd Class	0.14	No	131.00	Nos	18.34
6.	Man mazdoor	1.80	No	101.00	Nos	181.80
7.	Women Mazdoor	1.40	No	101.00	Nos	141.40
8.	Add Extra 15%on M.L					52.58
						1485.17
9	Add T.O.T. @4%					59.40
10	Sundries					0.43
Total Rs.						1545.00

2) R.C.C.Works

V.R.C.C.(1:2:4) Nominal mix using 20mm Normal size hard broken granite metal approved quarry with necessary reinforcement including casting, curing cost & conveyance of all materials.

Analysis of Rates

68

2 a) P.C.C.(1:2:4)

S.No.	Description of Item	Quantity	Unit	Rate	Per	Amount
1.	20mm HBG Metal	0.92	Cum	797.75	Cum	733.93
2.	Sand	0.46	cum	284.80	Cum	131.00
3.	Cement	0.23	Cum	2700.00	MT	894.24
4.	Mason Ist Class	0.2	No	180.00	Nos	30.00
5.	Man mazdoor	1.8	No	131.00	Nos	235.80.
6.	Women Mazdoor	1.4	No	101.00	Nos	141.40
7.	Vibrating charges	1.0	Cum	101.00	Nos	101.00
8.	Machiny mixing concrete	1.0	Cum	28.80	cum	28.80
9	Add Extra 15%on M.L					76.23
Total Rs.						2372.40

b) For steel reinforcement

S.No.	Description of Item	Quantity	Unit	Rate	Per	Amount
1.	cost of steel	1.00	MT	27500	MT	27500.00
2.	Fabrication charges	1.00	MT	5.00	Kg	5000.00
3.	Add 15% on M.L.					750.00
						33250.00
4.	Add T.O.T. @4%					1330.00
5.	Sundries					0.00
Total Rs.						34580.00

c) V.R.C.C (1:2:4) for bed blocks, column footings including form work centering charges

S.No.	Description of Item	Quantity	Unit	Rate	Per	Amount
1.	V.P.C.C (1:2:4)	1.00	Cum	2372.40	Cum	2372.40
2.	Centering Charges	1.00	Cum	430.00	Cum	430.00
3.	Steel @0.5% = 0.5/ 100=0.005m ³ (0.005x7.85t/m ³ = 0.04t	0.04	MT	34580.00	MT	1383.20
						4185.60
4.	Add T.O.T. @4%					167.40
	Sundries					0.00
Total Rs.						4353.00

d) V.R.C.C (1:2:4) for columns rectangular beams, pedestals including form work at centering charges.

S.No.	Description of Item	Quantity	Unit	Rate	Per	Amount
1.	V.P.C.C. (1:2:4)	1.00	Cum	2372.40	Cum	2372.40
2.	Centering Charges	1.00	Cum	675.00	Cum	675.00
3.	Steel for columns, beams @1.5% = 1.5/ 100x7.85=0.117t	0.117	MT	34580.00	MT	4072.00
						<u>7119.40</u>
4.	Add T.O.T. @4%					284.77
5.	Sundries					0.83
Total Rs.						7405.00

e) V.R.C.C (1:2:4) for slabs, lintels including form work at centering charges upto 100mm, thick

S.No.	Description of Item	Quantity	Unit	Rate	Per	Amount
1.	V.P.C.C (1:2:4)	1.00	Cum	2372.40	Cum	2372.40
2.	Centering Charges	10.00	Cum	710.00	Cum	710.00
3.	Steel for slabs @1% = 1/100 x 7.85 = 0.0785 t	0.0785	MT	34580.00	MT	2714.53
						<u>5796.63</u>
	Add T.O.T. @4%					231.87
	Sundries					1.20
Total Rs.						6030.00

3. Pointing to R.R.Masonry in CM(1:4) mix using cost & conveyance of Cement, sand and all materials from approved sources to site and labour charges for point neatly etc.

Analysis of Rates

70

S.No.	Description of Item	Quantity	Unit	Rate	Per	Amount
	Cost of CM(1:4)	0.09	Cum			
1.	Cement = $\frac{1}{4} \times 1.44 \times 0.09$	0.032	t	2700.00	Mt	87.48
2.	Sand = $\frac{1}{4} \times 0.09$	0.09	Cum	284.80	Cum	25.63
3.	Mining Charges	1.0	Cum	32.50	Cum	32.50
4.	mason Ist Class	0.48	Nos.	150.00	Nos	72.00
5.	2nd Class	1.12	Nos	131.00	Nos	146.72
6.	Man mazdoor	0.50	Nos	101.00	Nos	55.00
7.	Women Mazdoor	1.10	Nos	101.00	Nos	111.10
8.	Add 15% on ML					57.72
						588.15
9.	Add TOT @ 4%					23.53
10.	Sundries					0.32
Total Rs.						612.00

4. Cement concrete flooring (1:2:4) using 12mm HBG machine crushed chips from approved quarry to site of work including curing cost and conveyance of all materials completed.

S.No.	Description of Item	Quantity	Unit	Rate	Per	Amount
1.	12mm HBG metal	0.92	Cum	680.25	cum	625.83
2.	crushed chips					
3.	Sand	0.46	cum	284.80	cum	131.00
4.	Cement ($0.23\text{m}^3 \times 1.44 = 0.33\text{t}$ (or) 0.331	0.23 (or) 0.331	cum MT	2700	mt	894.24
5.	Mason ISt class	0.06	Nos	150.00	nos	9.00
6.	2nd Class	0.14	nos	131.00	nos	18.34
7.	Man mazdoor	1.80	nos	101.00	nos	181.80
8.	Women Mazdoor	1.40	nos	101.00	nos	141.40
9.	Add 15% Extra on ML					52.58
						2054.19
10.	Add TOT @4%					82.17
11.	Sundries					0.64
Total Rs.						2137.00

5 a) Supply and fixing teak wood fully paneled with 10x 4 cm styles, and 10x4cm rails and 3.5CM TH panels with teak wood fram of 6.25x 10cm size including cost of hold fasts, but hinges and labour charges for fixing door in position and fixing furniture etc., complete for one door of size 1.100 x 2.00 of area 2.2 sqm.

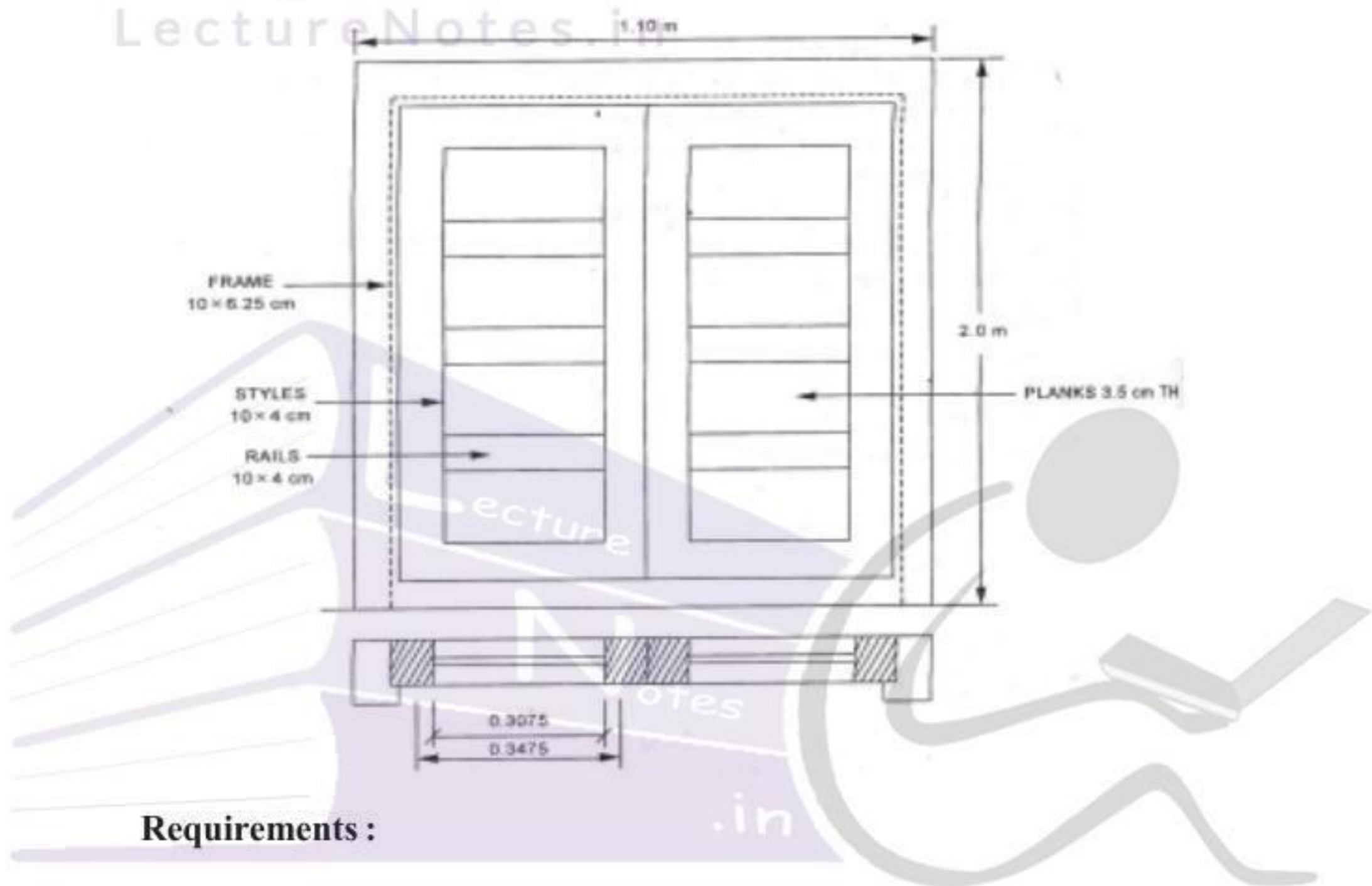

Requirements :

- i) Verticals = $2 \times 2.0 \times 0.10 \times 0.0625 = 0.0250$
 ii) Horizontals = $1 \times 1.10 \times 0.10 \times 0.0625 = 0.0068$
 iii) Styles = $4 \times 1.937 \times 0.10 \times 0.04 = 0.0300$
 iv) Rails = $2 \times 5 \times 0.5075 \times 0.10 \times 0.04 = 0.0020$
 v) Planks = $2 \times 4 \times 0.364 \times 0.3475 \times .035 = 0.0354$
0.0090m³

S.No.	Description of Item	Quantity	Unit	Rate	Per	Amount
1.	wood Cost	0.009	Cum	25000	cum	2470.00
2.	Butt Hinges	6	Nos	20	each	120.00
3.	Z-hold fasts	6	Nos	10	each	60.00
4.	Cost of labour	2.2	sqm	800	sqm	1760.00
					Total	4410.00

Cost of door per 1m² = $4410 / 2.2 = 2004.54$ say Rs.2010/-

5 b) Supply and fixing teak wood fully panned with 10x 4 cm styles, and 10x4cm rails and 3.5CM TH panels with teak wood fram of 6.25x 10cm size including cost of hold fasts, but hinges and labour charges for fixing window in position and fixing furniture etc., complete for one window of size 1.0x1.2 of area 1.2 sqm.

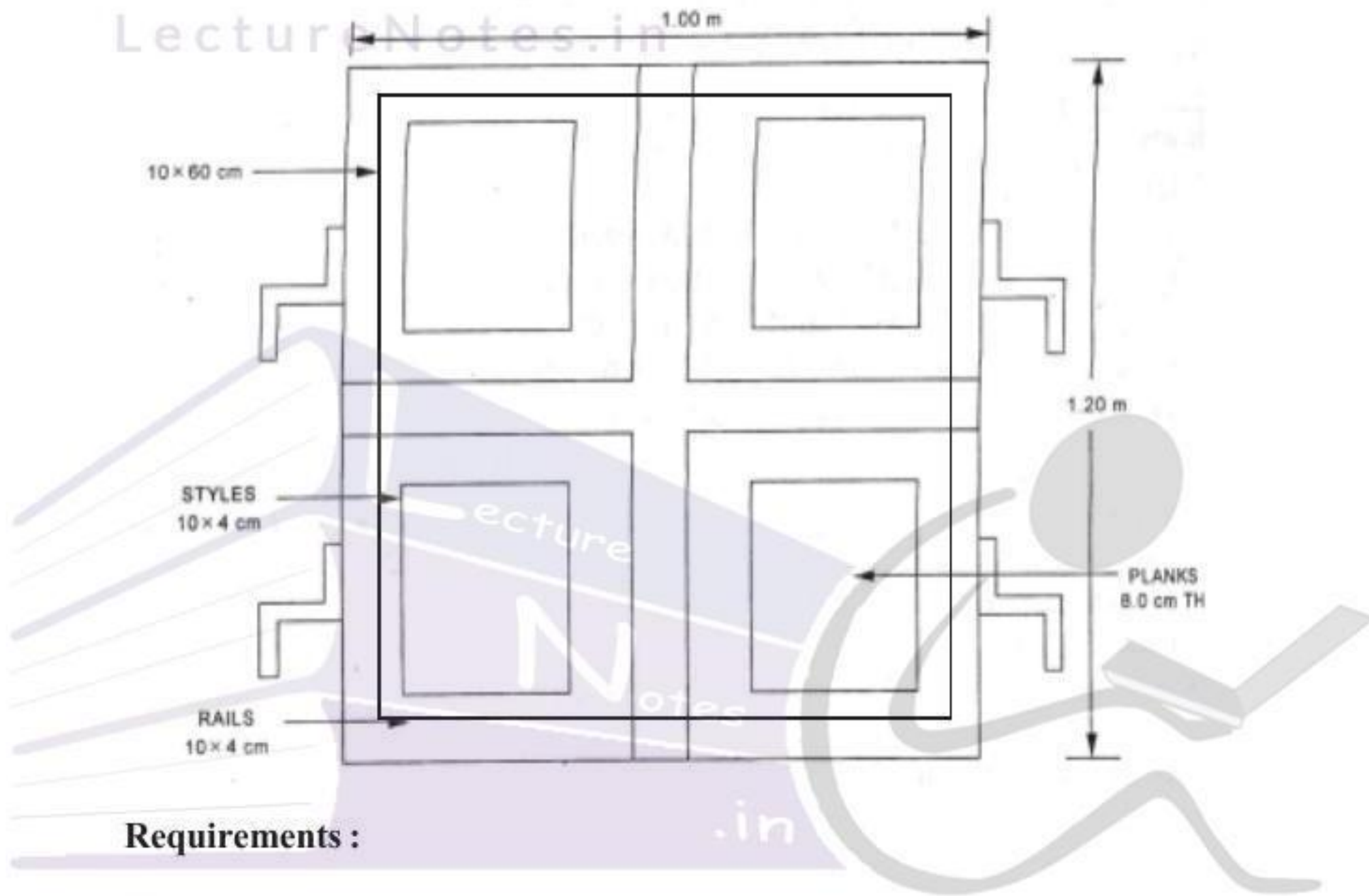

Requirements :

- i) Verticals = $3 \times 1.2 \times 0.10 \times 0.0625 = 0.0225$
 - ii) Horizontals = $3 \times 1.00 \times 0.10 \times 0.0625 = 0.0188$
 - iii) Styles = $4 \times 2 \times 0.10 \times 0.04 = 0.0160$
 - iv) Rails = $4 \times 2 \times 0.4062 \times 0.10 \times 0.04 = 0.0012$
 - v) Planks = $4 \times 0.3102 \times 0.2102 \times 0.03 = 0.0070$
- 0.0076m³**

S.No.	Description of Item	Quantity	Unit	Rate	Per	Amount
1.	wood Cost	0.0076	Cum	25000	cum	1900.00
2.	Butt Hinges	6	Nos	20	each	120.00
3.	Z-hold fasts	4	Nos	10	each	40.00
4.	Cost of labour	1.2	sqm	1000	sqm	1200.00
Total						3260.00

Cost of door per 1m² = $3260 / 1.2 = 2716.67$ say Rs.2720/-

EXERCISE**Short Answer Questions**

- Calculate the Cement contents for the following
 - C.C.(1:5:10) using 40mm H.B.G.Metal for 25m³ work
 - Brick work in CM (1:6) using country Bricks for 15m³ of work if 0.38 m³ of CM(1:6) is required for 1m³ of Brick work.
- Calculate the Rates of following materials by using the lead statement given below.

No.	Material	Rate of Source	Lead in KM			Conveyance Charge per
			ST	CT	MT	
1.	Cement	Rs.2100/10KN(tonn)	3	2	3	Rs.2.5/m ³
2.	Bricks	Rs.850/100nos	1	1	5	Rs.40/1000Nos/Km
3.	Sand	Rs. 15/m ³	4	3	5	Rs.12.00 / km/cum
4.	40mm HBG Metal	Rs. 250/m ³	2	1	2	Rs.7.50/Km/m ³

Essay type Questions

- Prepare a data sheet and calculate the cost of the items given below:
 - Brick masonry in C.M. (1:6) with country bricks-unit 1cum.
600Nos. country bricks.
0.38m³ C.M.(1:6)
1.40Nos. Masons
0.7 Nos. Man Mazdoor
2.1 Nos. Woman Mazdoor
L.S. Sundries.
 - C.C.(1:5:10) using 40mm HBG metal unit 1cum.
0.92m³..... 40mm size HBG metal
0.46m³..... Sand
0.092m³..... Cement
0.2 Nos Mason
1.8 Nos Man Mazdoor
1.4 Nos. Woman Mazdoor
L.S. Sundries.

Labour charges:

- Mason- Rs. 90 per day.
- Man Mazdoor - Rs. 70 per day
- Woman Mazdoor - Rs. 70 per day.
- Mixing Charges of C.M. Rs. 20=00 per m³.

S.No.	Material	Cost at Source		Per	Lead in Km	Conveyance Charges per Km
		Rs.	Ps.			
1	40mm HBG metal	210	=00	m ³	16	Rs.6=00/m ³
2	Sand	16	=00	m ³	18	Rs.3=00/m ³
3	Bricks country	780	=00	1000Nos	at site	--
4	Cement	2600	=00	10KN or 1tonne	at site	--

Chapter

6

ESTIMATION OF QUANTITIES OF STEEL & R.C.C. ELEMENTS

Example 1: Prepare the bar bending schedule of the given figure for R.C.C. beam.

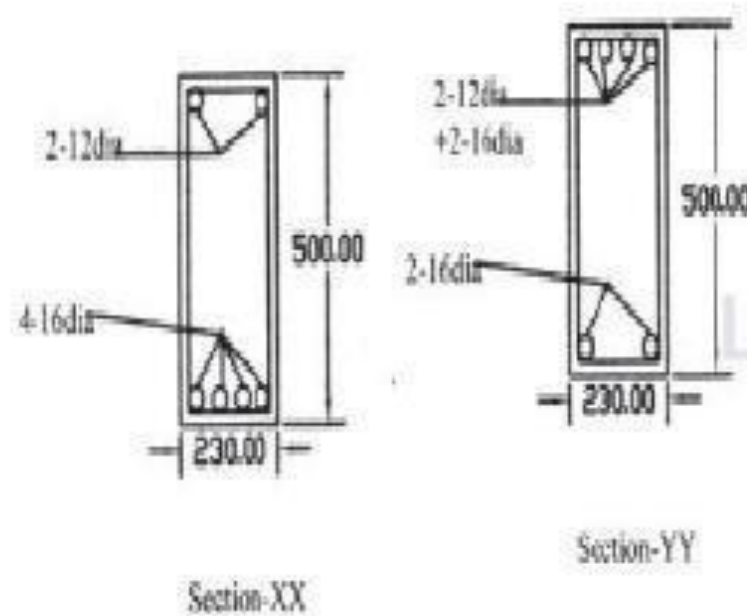
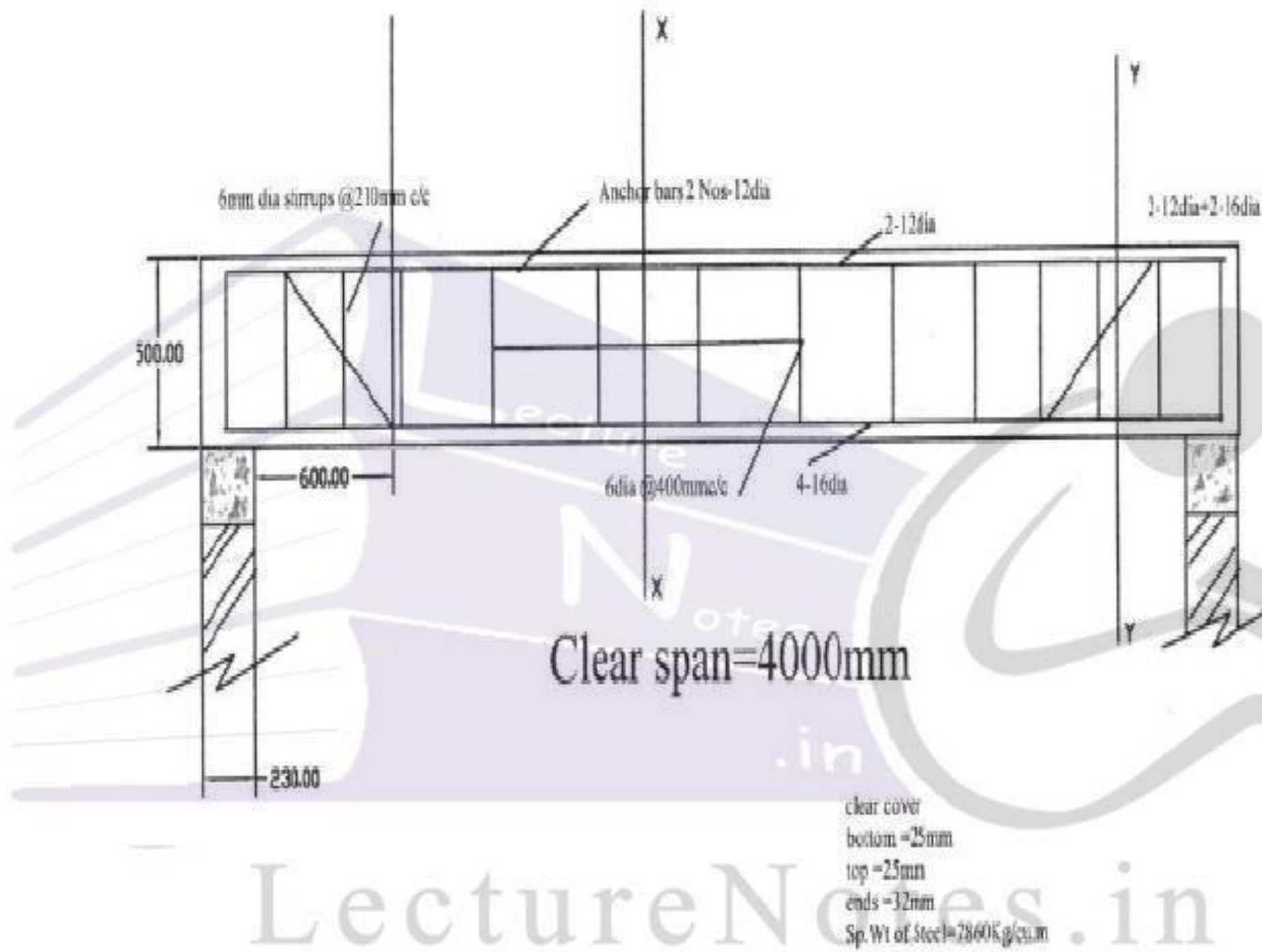

Name.	Shape	Dia.	No.	Length in m	Total Length in m	Self weight in kg/m	Total Weight in Kg
	main bars $4000 + 2 \times 230 - 2 \times 32 = 4396$	16	2	$4396 + 2 \times (9 \times 16)$ $= 4684 \text{ mm}$ $= 4.684 \text{ m}$	4.684×2 $= 9.368 \text{ m}$	$\frac{\pi}{4} \times \left(\frac{16}{1000}\right)^2 \times 7860$ $= 1.58$	1.58×9.368 $= 14.8$
B	Anchor bars $4000 + 2 \times 230 - 2 \times 32 = 4396$	12	2	$4396 + 2 \times (9 \times 12)$ $= 4612 \text{ mm}$ $= 4.612 \text{ m}$	4.612×2 $= 9.224 \text{ m}$	$\frac{\pi}{4} \times \left(\frac{12}{1000}\right)^2 \times 7860$ $= 0.89$	0.89×9.224 $= 8.2$
E	Cranked bars $500 - 2 \times 25 - 16 = 434$ 798 2800	16	2	$4396 + 2 \times (9 \times 16) +$ $2(0.414 \times 434)$ $= 5043 \text{ mm}$ $= 5.043 \text{ m}$ Additional length for each crank = 0.414d	5.04×2 $= 10.08$	$\frac{\pi}{4} \times \left(\frac{16}{1000}\right)^2 \times 7860$ $= 1.58$	1.58×10.08 $= 15.92$
A	 450 180	6	17	$2(450 + 180) +$ $2 \times 9 \times 6$ $= 1368 \text{ mm}$ $= 1.368 \text{ m}$	1.368×17 $= 23.256$	$\frac{\pi}{4} \times \left(\frac{6}{1000}\right)^2 \times 7860$ $= 0.22$	0.22×23.256 $= 5.16$
M	Height = $500 - 2 \times 25 = 450$ Width = $230 - 2 \times 25 = 180$			No. of stirrups = $((798/210) + 1) \times 2$ $+ (2800/400) = 17 \text{ Nos}$			

Example 2: Prepare the bar bending schedule of the given figure for R.C.C. Lintel

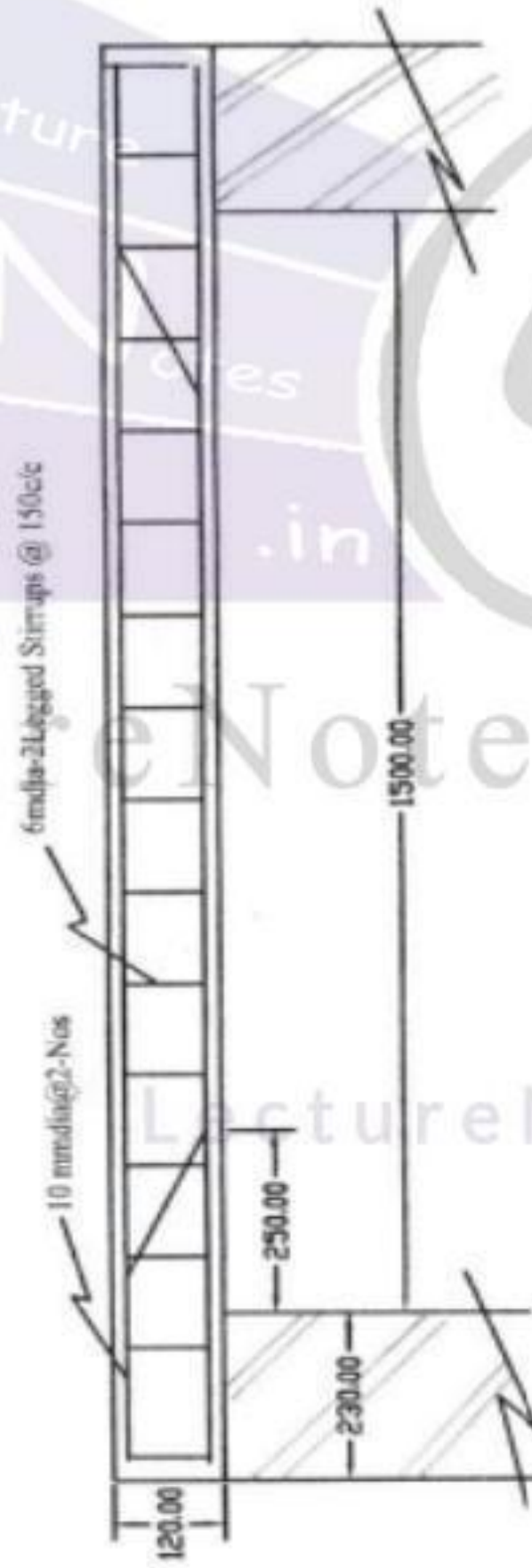

R.C.C. LINTEL

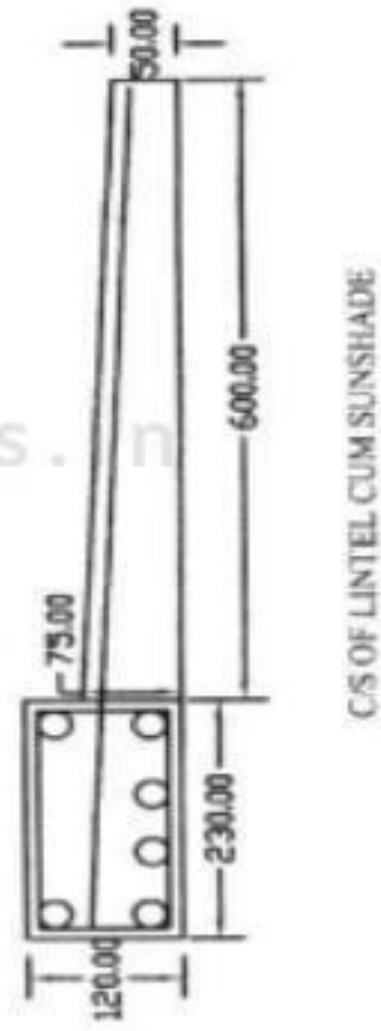

LONGITUDINAL SECTION OF R.C.C. LINTEL

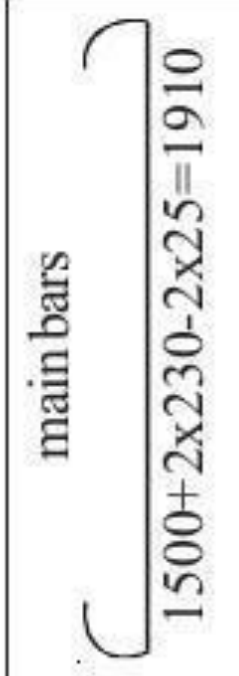
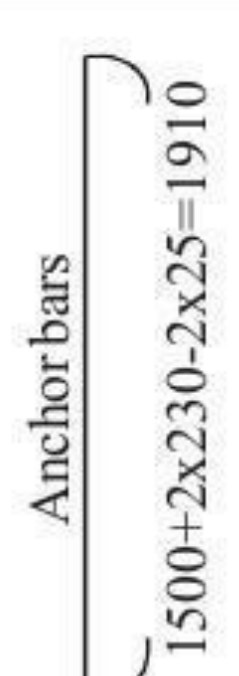

C/S OF LINTEL CUM SUNSHADE

Name.	Shape	Dia.	No.	Length in m	Total Length in m	Self weight in kg/m	Total Weight in Kg
	 <p>main bars 1500+2x230-2x25=1910</p>	12	2	1910+2x(9x12) = 2126mm = 2.1264m	2.126 x 2 = 4.252m	$\frac{\pi}{4} \times \left(\frac{12}{1000}\right)^2 \times 7860$ = 0.89	0.89x 4.252 = 3.78
L	 <p>Anchor bars 1500+2x230-2x25=1910</p>	10	2	1910+2x(9x10) = 2090mm = 2.090m	2.09 x 2 = 4.18m	$\frac{\pi}{4} \times \left(\frac{10}{1000}\right)^2 \times 7860$ = 0.62	0.62x 4.18 = 2.59
I							
N	 <p>Cranked bars 120-2x25-12= 58</p>	12	2	1910+2x(9x12)+ 2(0.414x58) = 2174mm = 2.174m Additional length for each crank = 0.414d	2.174 x 2 = 4.348	$\frac{\pi}{4} \times \left(\frac{12}{1000}\right)^2 \times 7860$ = 0.89	0.89x 4.348 = 1.87
T							
E							
L	 <p>Height = 120-2x25=70 Width = 230-2x25=180</p>	6	14	2(70+180)+ 2x9x6 = 608mm = 0.608m	0.608x14 = 8.512	$\frac{\pi}{4} \times \left(\frac{6}{1000}\right)^2 \times 7860$ = 0.22	0.22x8.512 = 1.87
No. of stirrups = ((1910/150)+1) = 14 Nos							

Example 3: Prepare the bar bending schedule of the given figure for R.C.C. Lintel

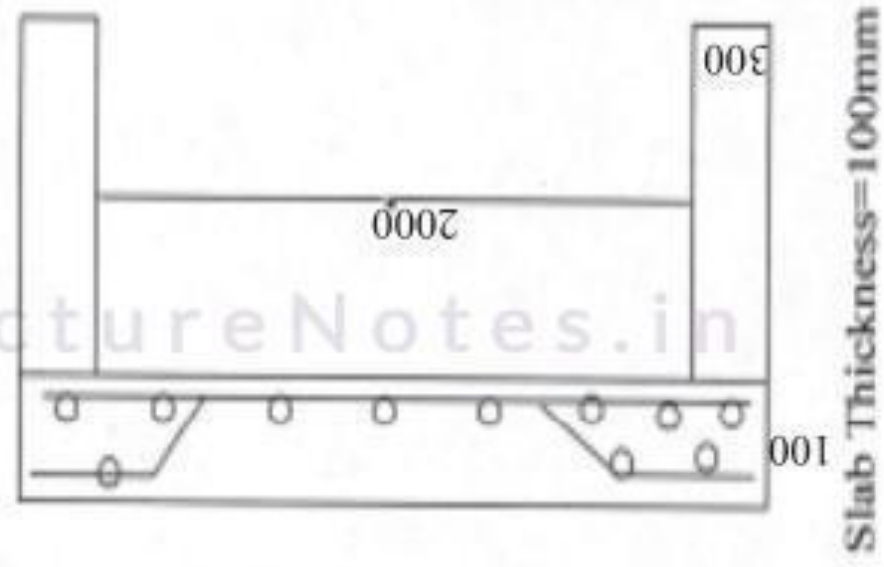
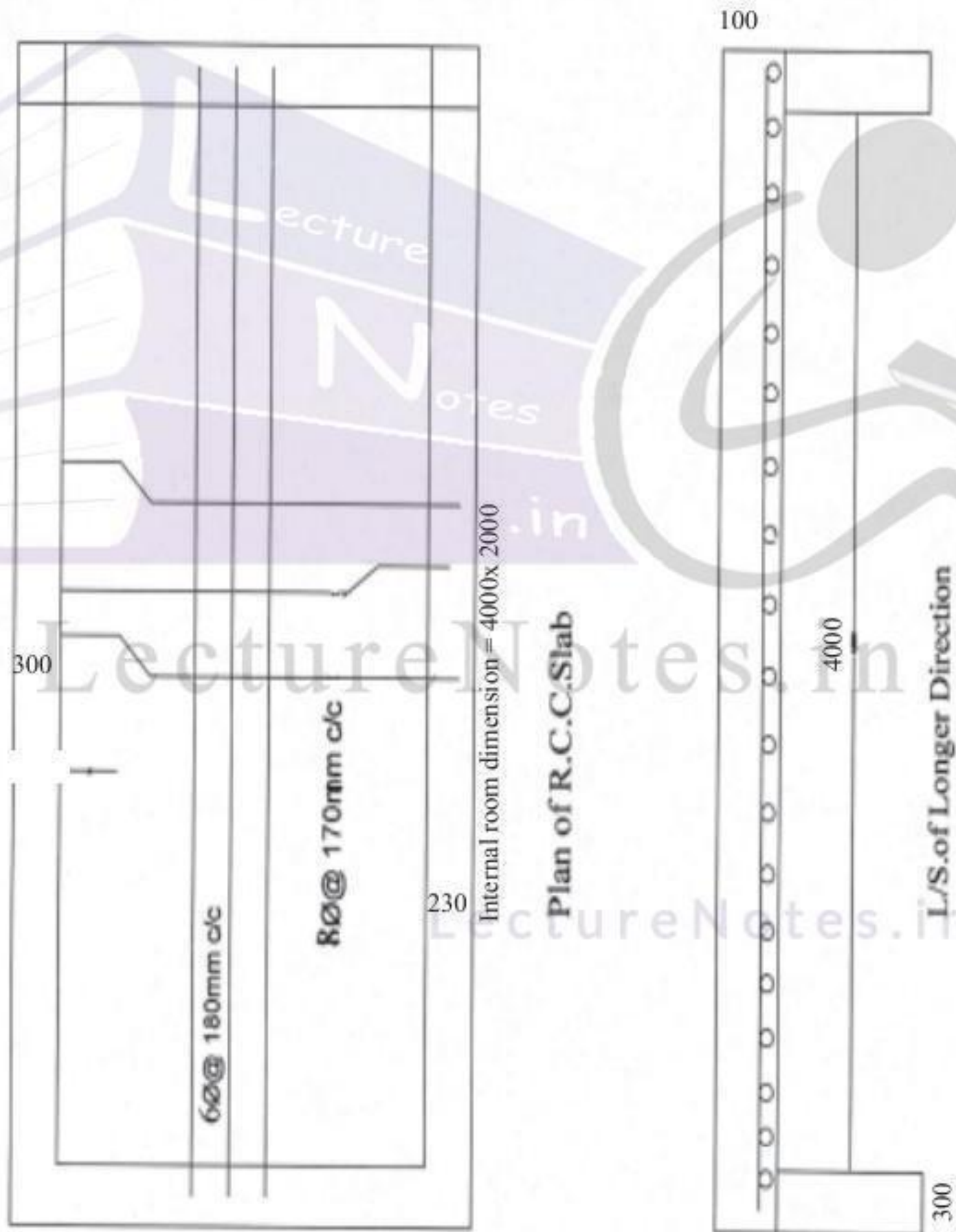

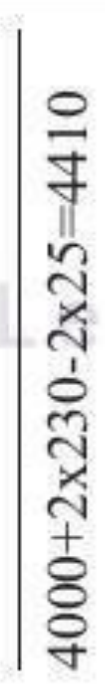
Name.	Shape	Dia.	No.	Length in m	Total Length in m	Self weight in kg/m	Total Weight in Kg
S	 <p>Cranked bars 100-2x13-8=66 2000+2x230-2x25=2410</p>	8	$\frac{4410}{170} + 1 = 27$	2410+2x(9x8)+(0.414x66)=2581.3mm = 2.581m Additional length for each crank = 0.414d	2.581 x 27 = 69.7	$\frac{\pi}{4} \times \left(\frac{8}{1000}\right)^2 \times 7860 = 0.39$	0.39x69.7 = 27.53
L							
A							
B	 <p>4000+2x230-2x25=4410</p>	6	$\frac{2410}{180} + 1 = 15$	4.41m	4.41x15 = 66.15	$\frac{\pi}{4} \times \left(\frac{6}{1000}\right)^2 \times 7860 = 0.22$	0.22x66.15 = 14.553

EXERCISE

1) Prepare the Bar bending schedule for the beam shown below.

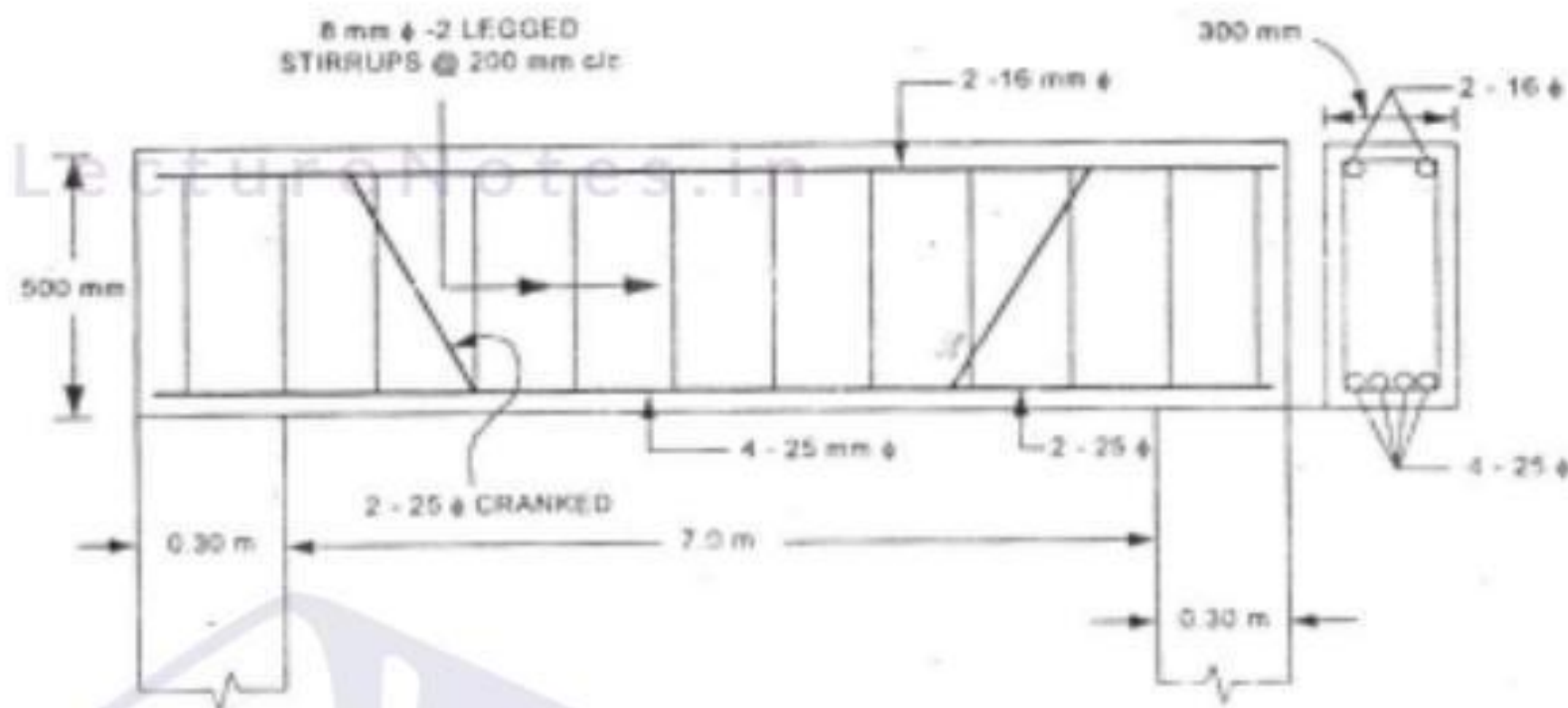

2) Prepare the Bar bending schedule of a simply supported R.C.C. Lintels from the following specification:

- Size of lintel 300mm wide x 200mm depth. Main bars in tension zone of Fe 250 (grade I) 3 bars of 16mm dia., one bar is cranked through 45° at 170 mm from each end
- 2 No. anchor bars at top 8mm dia.
- Two legged stirrups @ 150mm c/c of 6mm dia. through out.
- Clear span of the lintel is 1150mm.
- Bearing on either side is 150mm.



EARTH WORK CALCULATIONS

7.1 Introduction:-

Generally all the Civil Engineering projects like roads, railways, earth dams, canal bunds, buildings etc. involves the earth work. This earth work may be either earth excavation or earth filling or Some times both will get according to the desired shape and level. Basically the volume of earthwork is computed from length, breadth, and depth of excavation or filling.

In this chapter the various methods of calculating the earth work quantities shall be discussed.

7.2 Lead and Lift:

Lead:

It is the average horizontal distance between the centre of excavation to the centre of deposition. The unit of lead is 50m.

Lift:

It is the average height through which the earth has to be lifted from source to the place of spreading or heaping. The unit of lift is 2.00m for first lift and one extra lift for every 1.0m. for example when earth is to be lifted for 4.5m, Four lifts are to be paid to the contractor.

i.e. Upto2.0 -	1 lift	} Total 04 lifts
1.0 -	1 Lift	
1.0 -	1 lift	
0.5 -	1 lift	

7.3 Calculation of earth work for Roads:

7.3.1 case 1) volume of earth work in banking or in cutting having "no longitudinal slope".

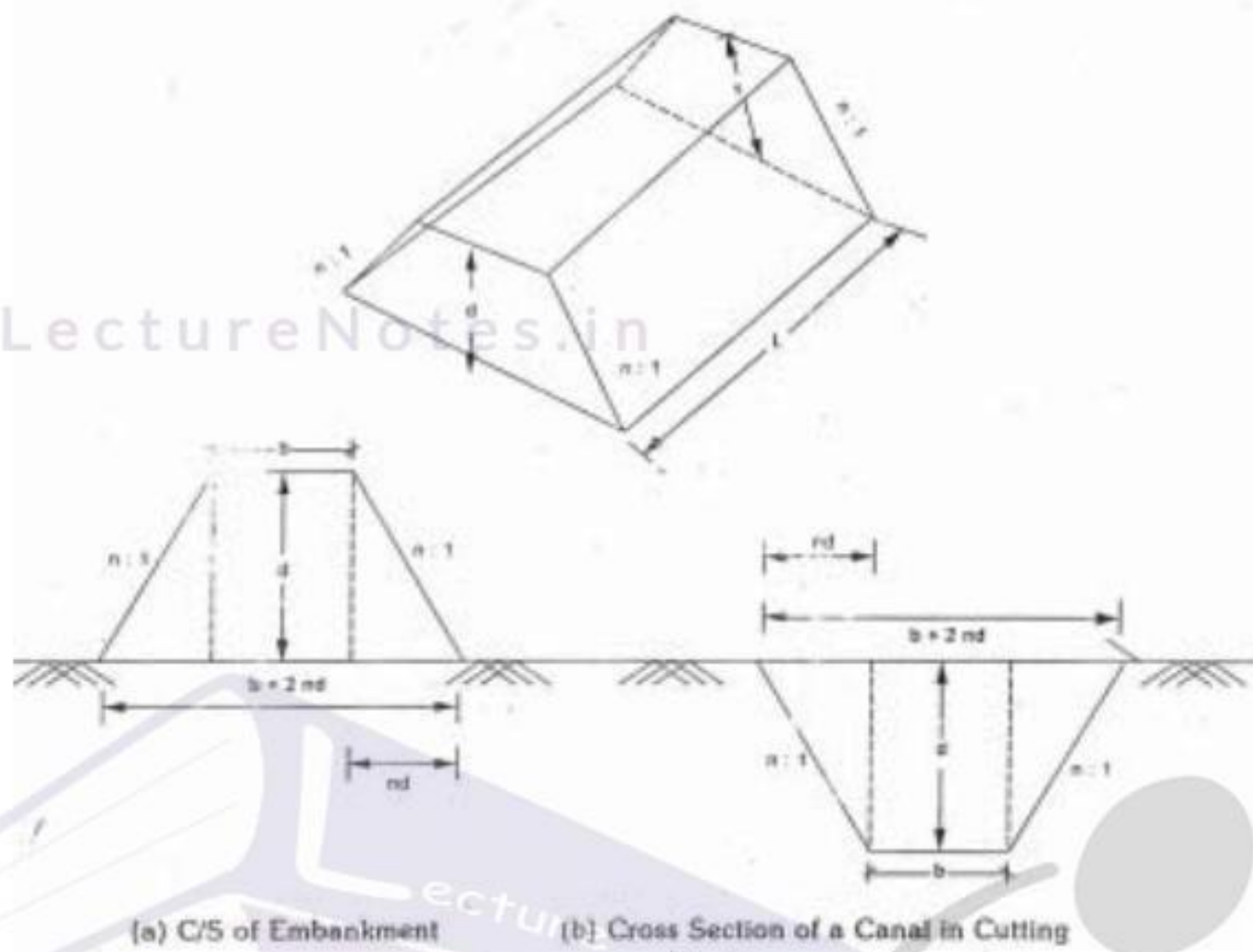

$$V = (bd + 2 \times \frac{1}{2} \times nd \times d)L$$

$$V = (bd + nd^2)L$$

Case 2:

When the ground is in longitudinal slope or the formation has uniform gradient for a length the earth work may be calculated by the following methods.

1. By Mid Section or Mid ordinate method.

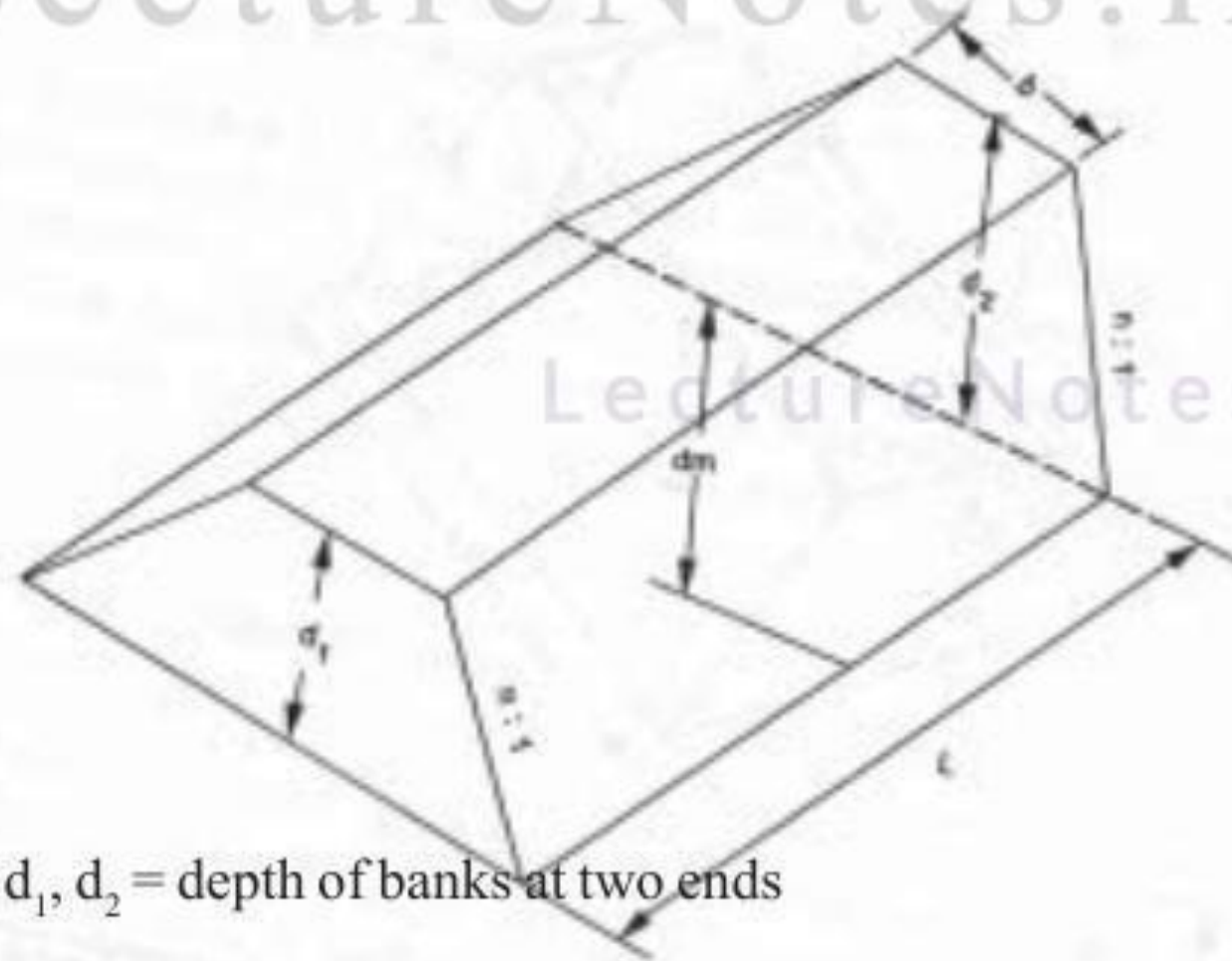

Where d_1, d_2 = depth of banks at two ends

$$\text{Mid ordinate (or) Average depth (d}_m) = \frac{d_1 + d_2}{2}$$

$$\text{Area of mid section (A}_m) = (bd_m + nd_m^2)$$

$$\text{volume of earth work (v)} = A_m \times L = (bd_m + nd_m^2) \times L$$

ii) Trapezoidal formula: (for two sections)

In this method also called mean sectional area method

Let A_1 & A_2 be two areas at two ends.

$$A = (bd_1 + nd_1^2), \quad A_2 = (bd_2 + nd_2^2)$$

$$A_m = \frac{A_1 + A_2}{2}$$

$$\text{Volume of earth work (v)} = A_m \times L$$

iii) Trapezoidal formula for a series of c/s areas at equal intervals.

Let $A_1, A_2, A_3, \dots, A_n$ are the cross sectional areas along L.S of Road 'L' is the distance between two cross sections

The volume of earth work

$$V = L \left[\left(\frac{A_1 + A_n}{2} \right) + (A_2 + A_3 + \dots + A_{n-1}) \right] \text{ (or)}$$

$$= \frac{L}{2} [(A_1 + A_n) + 2(A_2 + A_3 + \dots + A_{n-1})]$$

$$= \frac{\text{length}}{2} [(\text{sum of first and last areas}) + 2(\text{remaining Areas})]$$

iv) Prismoidal formula for a series of cross sectional areas at equal intervals.

Note : This method is adopted when there is odd number of cross sections.

Volume of earth work

$$V = \frac{L}{3} [(A_1 + A_n) + 4(A_2 + A_4 + A_6 + \dots + A_{n-1}) + 2(A_3 + A_5 + \dots + A_{n-2})]$$

$$= \frac{\text{length}}{3} (\text{Sum of first and last areas}) + 4(\text{even areas}) + 2(\text{odd Areas})]$$

Example 7.1 : Find the volume of earth work in embankment of length 12m.

Top width is 5.5m and depth is 2.5m the side slopes are 1½:1

Sol : Top width b=5.5m

Depth d= 2.5m

side slopes =1½:1 i.e. n=1.5

length L=12m

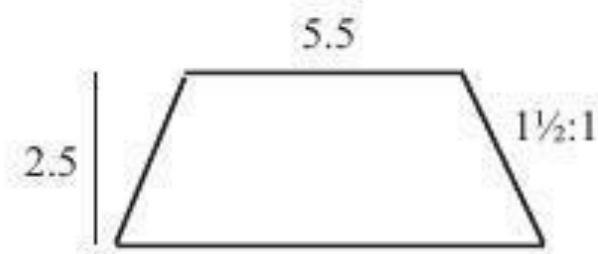

$$\begin{aligned} \text{Volume of earth work } V &= (bd+nd^2)L \\ &= (5.5 \times 2.5 + 1.5 \times 2.5^2)12 \\ &= 77.5\text{m}^3 \end{aligned}$$

Example 7.2 : The depths at two ends of an embankment of road of length 70m are 2m and 2.5m. The formation width and side slopes are 8m and 2:1 respectively. Estimate the Quantity of earth work by

a) Mid Sectional Area (ii) Mean sectional Area method.

Sol: a) b=8m, d1=2m, d2=2.5m, l=70m, n=2

$$\text{Mean depth } d_m = \frac{d_1+d_2}{2} = \frac{2+2.5}{2} = 2.25\text{m}$$

$$\text{Mid sectional Area} = A_m = bdm + ndm^2 = (8 \times 2.25 + 2 \times 2.25^2)2 = 28.125\text{m}^2$$

$$\text{Volume of earth work (V)} = A_m \times L = 28.125 \times 70 = 1968.75\text{m}^3.$$

b) Area of c/s at one end $A_1 = bd_1 + nd_1^2 = 8 \times 2 + 2 \times 2^2 = 24\text{m}^2$

$$\text{Area of C/s at other end } A_2 = bd_2 + nd_2^2 = 8 \times 2.5 + 2 \times 2.5^2 = 32.5\text{m}^2$$

$$\text{Mean Sectional Area (A}_m) = \frac{A_1 + A_2}{2} = \frac{24 + 32.5}{2} = 28.25\text{m}^2$$

$$\text{Volume of earth work (V)} = A_m \times L = 28.25 \times 70 = 1977.5\text{m}^3.$$

Example 7.3

The following width of road embankment is 10m. The side slopes are 2:1
The depth along the centre line road at 50m intervals are 1.25, 1.10, 1.50, 1.20, 1.0, 1.10, 1.15m calculate the Quantity of earth work by

- a) Mid sectional rule
- b) Trapezoidal rule
- c) Prismoidal rule

a) Mid Sectional rule : b=10m, n=2.

Chainage	Depths	Mean depth (d_m)	Area of ($bd_m + nd_m^2$)	Length b/w Chainages	Quantity (m^3) $A_m \times L$
0	1.25	1.175	14.51	50	725.56
50	1.10				
100	1.15	1.175	14.51	50	725.56
150	1.20	1.10	13.4	50	671.00
200	1.00	1.02	12.70	50	635.25
250	1.10	1.125	13.78	50	689.06
300	1.15				
Total					4135.49m ³

b) Trapezoidal rule

$$A = bd + nd^2$$

$$A_1 = bd_1 + nd_1^2 = 10 \times 1.25 + 2 \times 1.25^2 = 15.625 \text{ m}^2$$

$$A_2 = bd_2 + nd_2^2 = 10 \times 1.10 + 2 \times 1.10^2 = 13.42 \text{ m}^2$$

$$A_3 = 10 \times 1.15 + 2 \times 1.15^2 = 14.145 \text{ m}^2$$

$$A_4 = 10 \times 1.2 + 2 \times 1.2^2 = 14.88 \text{ m}^2$$

$$A_5 = 10 \times 1.0 + 2 \times 1^2 = 12.0 \text{ m}^2$$

$$A_6 = 10 \times 1.1 + 2 \times 1.1^2 = 13.42 \text{ m}^2$$

$$A_7 = 10 \times 1.15 + 2 \times 1.15^2 = 14.145 \text{ m}^2$$

Volume of earth work by Trapezoidal rule

$$\begin{aligned}
 v &= L \left[\left(\frac{A_1 + A_n}{2} \right) + (A_2 + A_3 + \dots + A_{n-1}) \right] \\
 &= 50 \left[\left(\frac{15.625 + 14.145}{2} \right) + (13.42 + 14.145 + 14.818 + 12.0 + 13.42) \right] \\
 &= 4137.50 \text{ m}^3
 \end{aligned}$$

c) By Prismoidal rule

$$\begin{aligned}
 v &= \frac{L}{3} [(A_1 + A_n) + 4(\text{even Areas}) + 2(\text{Odd Areas})] \\
 &= \frac{L}{3} [(A_1 + A_7) + 4(A_2 + A_4 + A_6) + 2(A_3 + A_5)] \\
 &= \frac{50}{3} [(15.625 + 14.145) + 4(13.42 + 14.88 + 13.42) + 2(14.145 + 12)] \\
 &= 4149 \text{ m}^3
 \end{aligned}$$

Example 7.4:- Estimate the Quantity of earth work for a portion of road from the following data

Chainage	0	1	2	3	4	5	6	7	8	9
RL	7.50	7.70	7.50	7.25	6.85	6.95	6.70	6.45	6.30	5.95

The formation level at Chainage 0 is 8.0 and having falling gradient of 1 in 100. The top width is 12m and side slopes 1½ horizontal to 1 vertical assuming the transverse direction is in level calculate the quantity of earth work Take 1 chain = 20m by using trepezoidol & Prismoidol formula.

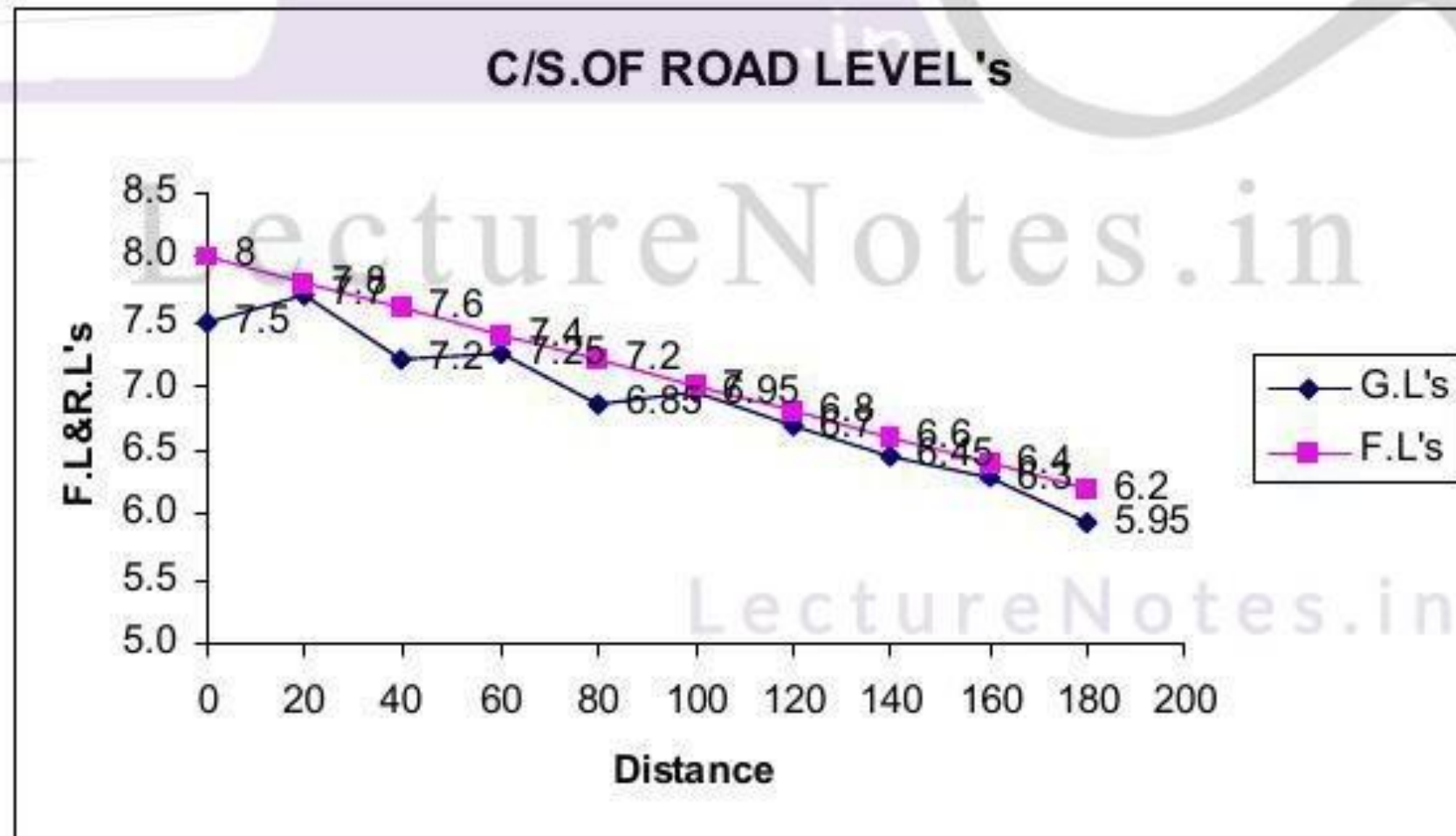

Sol :-

$$b=12m \quad n=5$$

Chainage	Distance	Reduced level	Formation Level	Depth(d) of		Area of	
				Embankment	Cutting	Embankment $bd+nd^2$	Cutting
0	0	7.50	8.0	0.50		6.375	
1	20	7.70	7.8	0.10		1.275	
2	40	7.50	7.6	0.10		1.215	
3	60	7.25	7.4	0.15		1.839	
4	80	6.85	7.2	0.35		4.38	
5	100	6.95	7.0	0.05		0.63	
6	120	6.70	6.8	0.10		1.215	
7	140	6.45	6.6	0.15		1.837	
8	160	6.30	6.4	0.10		1.215	
9	180	5.95	6.2	0.25		3.09	

Trapezoidal formula :

$$V = L \left[\left(\frac{A_1 + A_n}{2} \right) + (A_2 + A_3 + \dots + A_{n-1}) \right]$$

$$= 20 \left[\left(\frac{6.375 + 3.09}{2} \right) + (1.215 + 1.215 + 1.837 + 4.38 + 0.63 + 1.215 + 1.837 + 1.215) \right]$$

$$= 365.53m^3$$

Prismoidal formula:

$$V = \frac{L}{3} [(A_1 + A_n) + 4(\text{even areas}) + 2(\text{Odd areas})]$$

$$= \frac{L}{3} [(A_1 + A_{10}) + 4(A_2 + A_4 + A_6 + A_8) + 2(A_3 + A_5 + A_7 + A_9)]$$

$$= \frac{20}{3} [(6.375 + 3.09) + 4(1.215 + 1.837 + 0.63 + 1.837) +$$

$$2(1.215 + 4.38 + 1.815 + 1.215)]$$

$$= 317.27 m^3$$

Example 7.5:- The road has the following data

Chainage	0	20	40	60	80	100	120
RL of Ground	20.6	21.0	21.5	22.1	22.7	22.9	23.0

The formation level at chainage zero is 22.0 and having a rising gradient of 1 in 100 the top width is 12.0m and side slopes are 1½ :1 Assuming the transverse direction is in level. calculate the quantity of earth work by

- a) Trapezoidal formula b) Prismoidal formula

Chainage Distance	Reduced level	Formation Level	Depth (d)of		Area of	
			Embark-ment	Cut-ting	Embark-ment	Cutting
0	20.6	22.0	1.40		19.74	
20	21.0	22.2	1.20		16.56	
40	21.5	22.4	0.90		12.01	
60	22.1	22.6	0.50		6.375	
80	22.7	22.8	0.10		1.215	
100	22.9	23.0	0.10		1.215	
120	23.0	23.2	0.20		2.460	

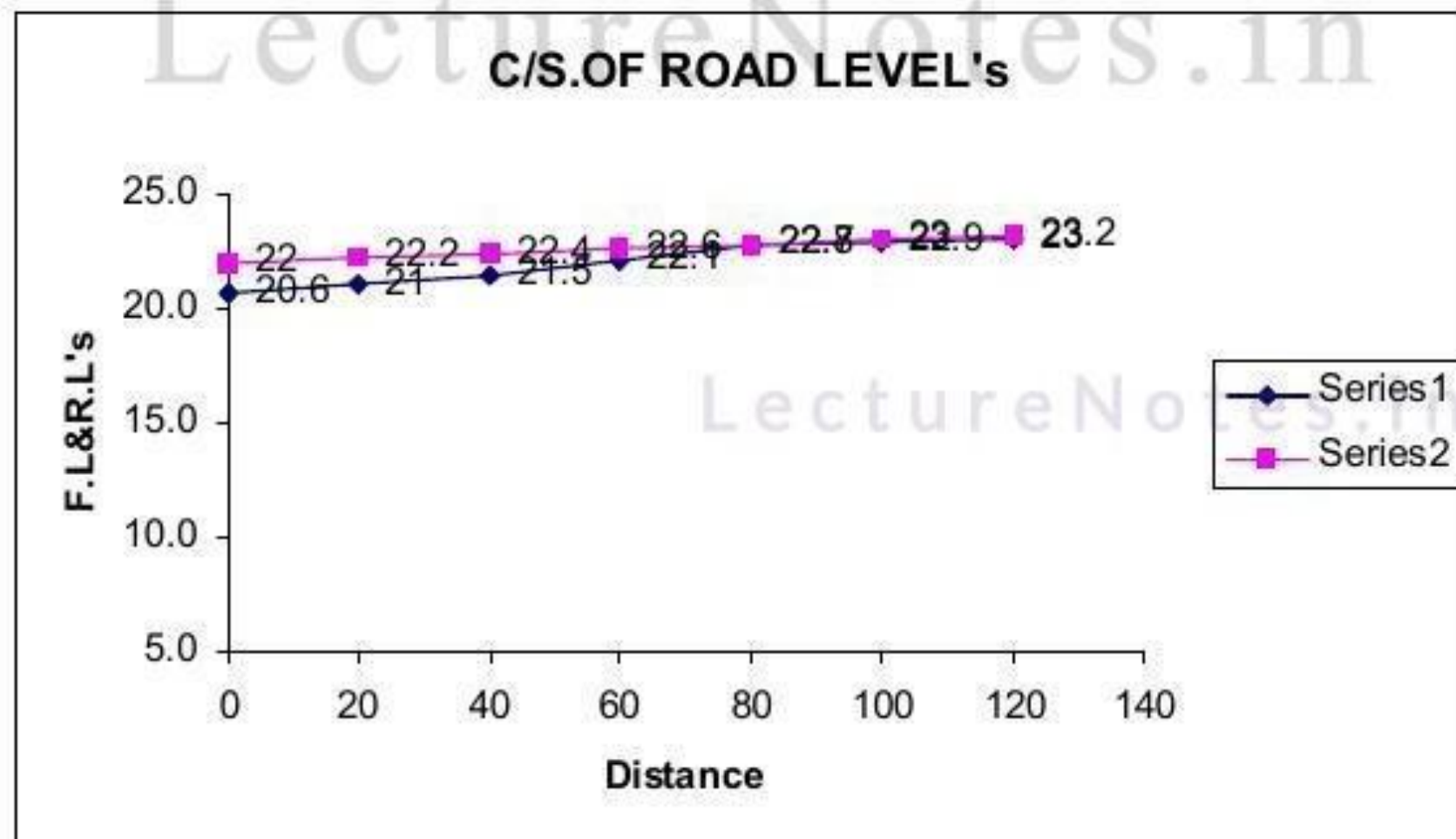

a) Trapezoidal formula:

Vol of earth work in embankment

$$V = L \left[\left(\frac{A_1 + A_n}{2} \right) + (A_2 + A_3 + \dots + A_{n-1}) \right]$$

$$= 20 \left[\left(\frac{19.74 + 2.46}{2} \right) + (16.56 + 12.01 + 6.375 + 1.215 + 1.215) \right]$$

$$= 969.5 \text{ m}^3$$

b) Prismoidal formula

$$V = \frac{L}{3} [(A_1 + A_n) + 4(\text{even Areas}) + 2(\text{Odd Areas})]$$

$$= \frac{20}{3} [(19.74 + 2.46) + 4(16.56 + 6.325 + 1.2 + 5) + 2(12.01 + 1.215)]$$

$$= 968.33 \text{ m}^3$$

LectureNotes.in

LectureNotes.in

Example 7.6:-From the above problem if the formation level at 0th chainage in 20m. Calculate the volume of earth work by using the formulas?

Chainage	Reduced level	Formation Level	Depth (d)of		Area of	
			Embankment	Cutting	Embankment	Cutting $bd+nd^2$
0	20.60	20.00	--	0.60	--	7.740
20	21.00	20.20	--	0.80	--	10.56
40	21.50	20.40	---	1.10	---	15.015
60	22.10	20.60	--	1.50	--	21.375
80	22.70	20.80	--	1.90	--	28.215
100	22.90	21.00	--	1.90	--	28.215
120	23.00	21.20	--	1.80	--	26.460

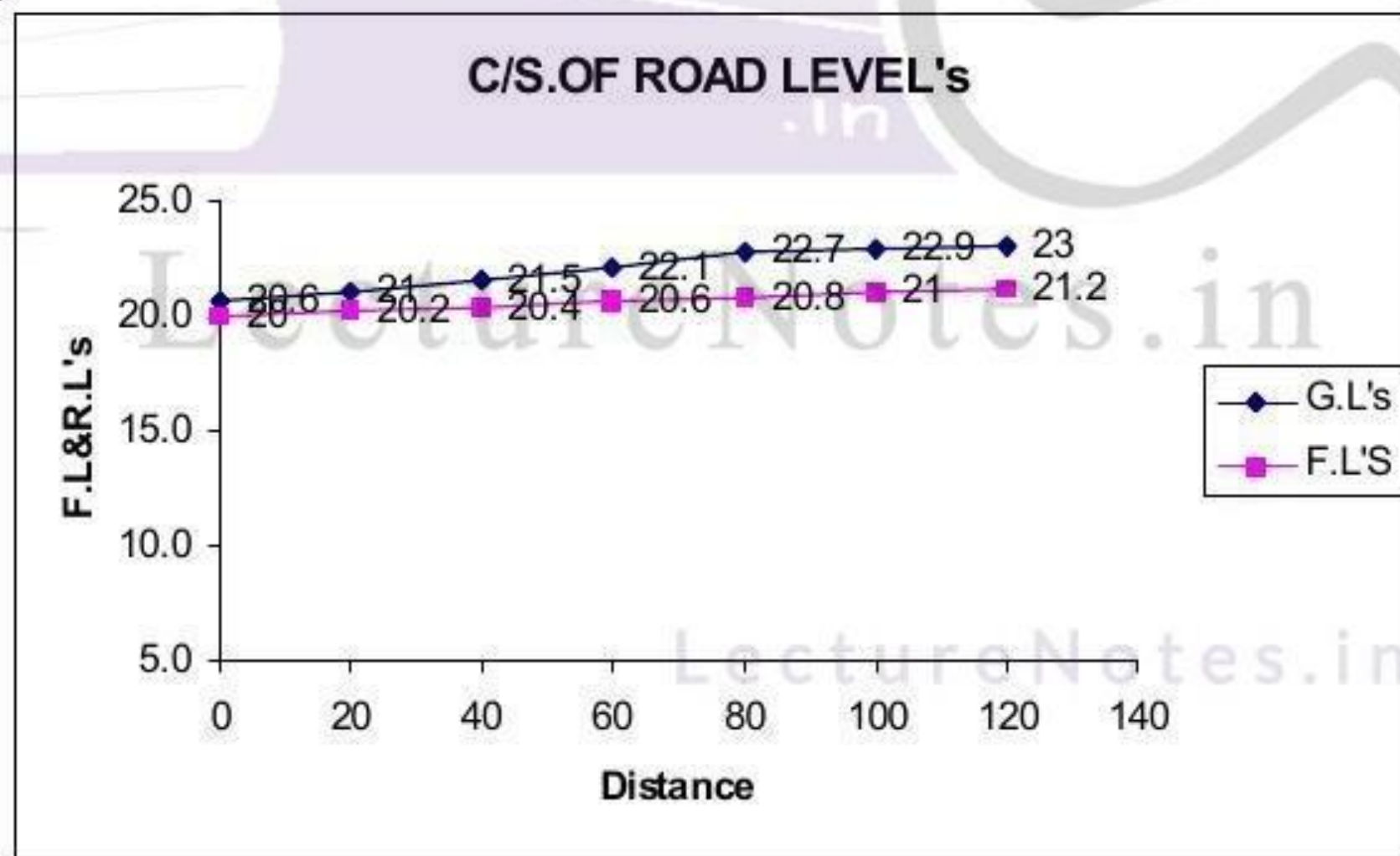

a) Trapezoidal formula:

Vol. of earth work in cutting

$$V = L \left[\left(\frac{A_1 + A_n}{2} \right) + (A_2 + A_3 + \dots + A_{n-1}) \right]$$

$$= 20 \left[\left(\frac{7.74 + 26.46}{2} \right) + (10.56 + 15.015 + 21.375 + 28.215 + 28.215) \right]$$

$$= 2409.6 \text{ m}^3$$

b) Prismoidal formulae :

$$V = \frac{L}{3} [(A_1 + A_n) + 4(\text{even areas}) + 2(\text{Odd areas})]$$

$$= \frac{L}{3} [(A_1 + A_7) + 4(A_2 + A_4 + A_6) + 2(A_3 + A_5)]$$

$$= \frac{20}{3} [(7.74 + 26.46) + 4(10.56 + 21.375 + 28.215) +$$

$$2(15.015 + 28.215)]$$

$$= 2408.4 \text{ m}^3$$

Example 7.7:- From the same above problem 7.6 if the gradient is in 100 falling calculate the quantity of earth work by using the formulas

Chainage	Reduced level	Formation Level	Depth (d) of		Area of	
			Embankment	Cutting	Embankment	Cutting
0	20.60	20.00	--	0.60	--	7.74
20	21.00	19.8	--	1.20	--	16.56
40	21.50	19.6	---	1.90	---	28.215
60	22.10	19.4	--	2.70	--	43.335
80	22.70	19.20	--	3.50	--	60.375
100	22.90	19.0	--	3.90	--	69.615
120	23.00	18.80	--	4.20	--	76.86

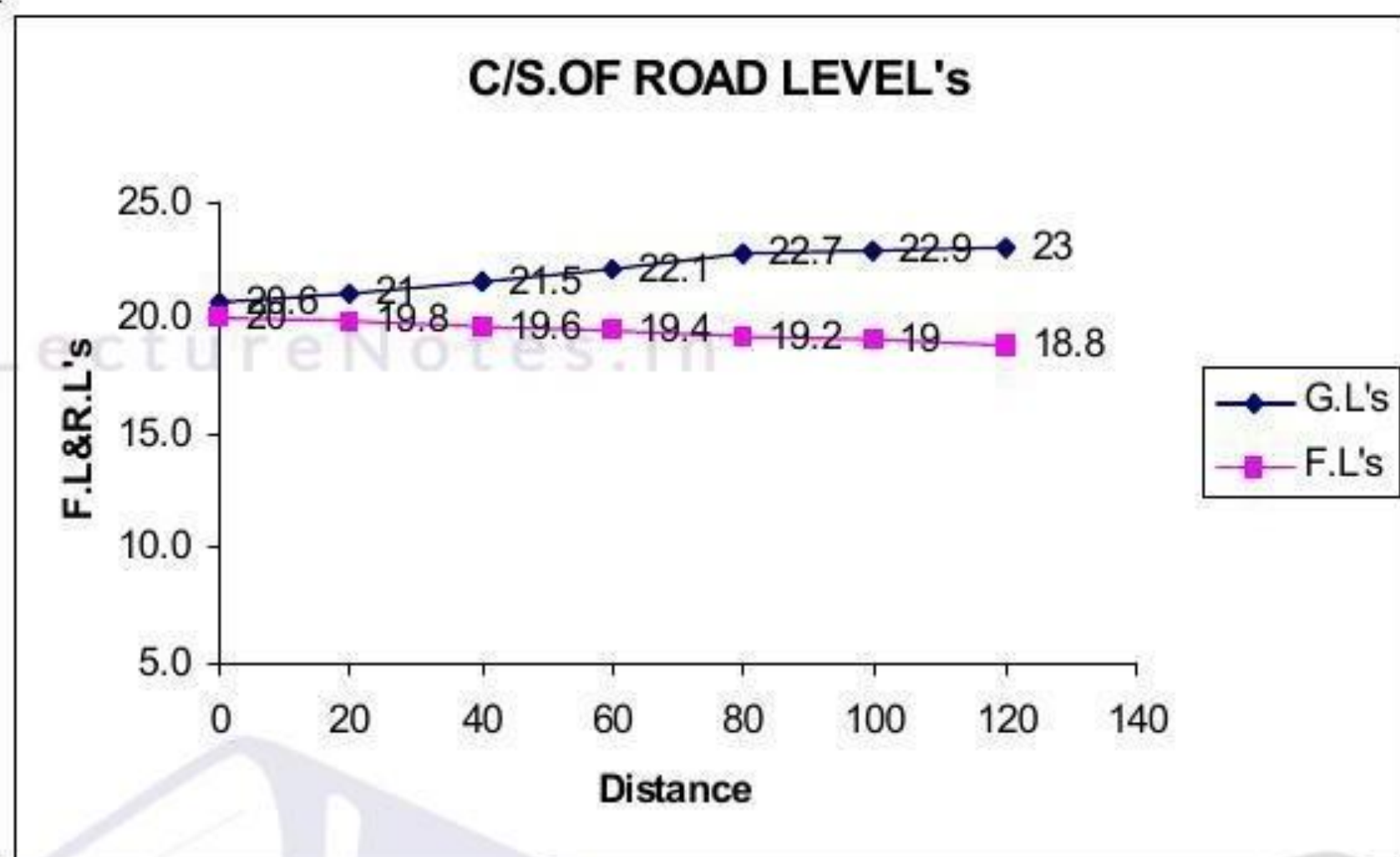

a) Trepzoidol formulae:

Vol.of earth work in cutting

$$V = L \left[\left(\frac{A_1 + A_n}{2} \right) + (A_2 + A_3 + \dots + A_{n-1}) \right]$$

$$= 20 \left[\left(\frac{7.74 + 76.86}{2} \right) + (16.56 + 28.215 + 43.335 + 60.375 + 69.615) \right]$$

$$= 5208 \text{ m}^3$$

b) Prismoidal formulae :

$$V = \frac{L}{3} [(A_1 + A_n) + 4(\text{even areas}) + 2(\text{Odd areas})]$$

$$= \frac{L}{3} [(A_1 + A_7) + 4(A_2 + A_4 + A_6) + 2(A_3 + A_5)]$$

$$= \frac{20}{3} [(7.74 + 76.86) + 4(16.56 + 43.335 + 69.615) + 2(28.215 + 60.375)]$$

$$= 5198.8 \text{ m}^3$$

Example 7.8:- From the problem 7.5 if the gradient is 1 in 100 raising upto 40th chainage and 1 in 100 falling ragient from 40th Chainage to 120th chainage. Calculate the vol of earth work by using the formulas.

Chainage (m)	R.L.	F.L.	Depth (d)of .		Area of .	
			Embank- ment	Cutting	Embank ment $bd+nd^2$	Cutting $bd+nd^2$
0	20.6	22.0	1.40		19.74	
20	21.0	22.20	1.20		16.56	
40	21.5	22.40	0.90		12.01	
60	22.1	22.20	0.10		1.215	
62.5			0.00	0.00	0.000	0.000
80	22.7	22.00		0.70		9.135
100	22.9	21.80		1.10		15.015
120	23.0	21.60		1.40		19.74

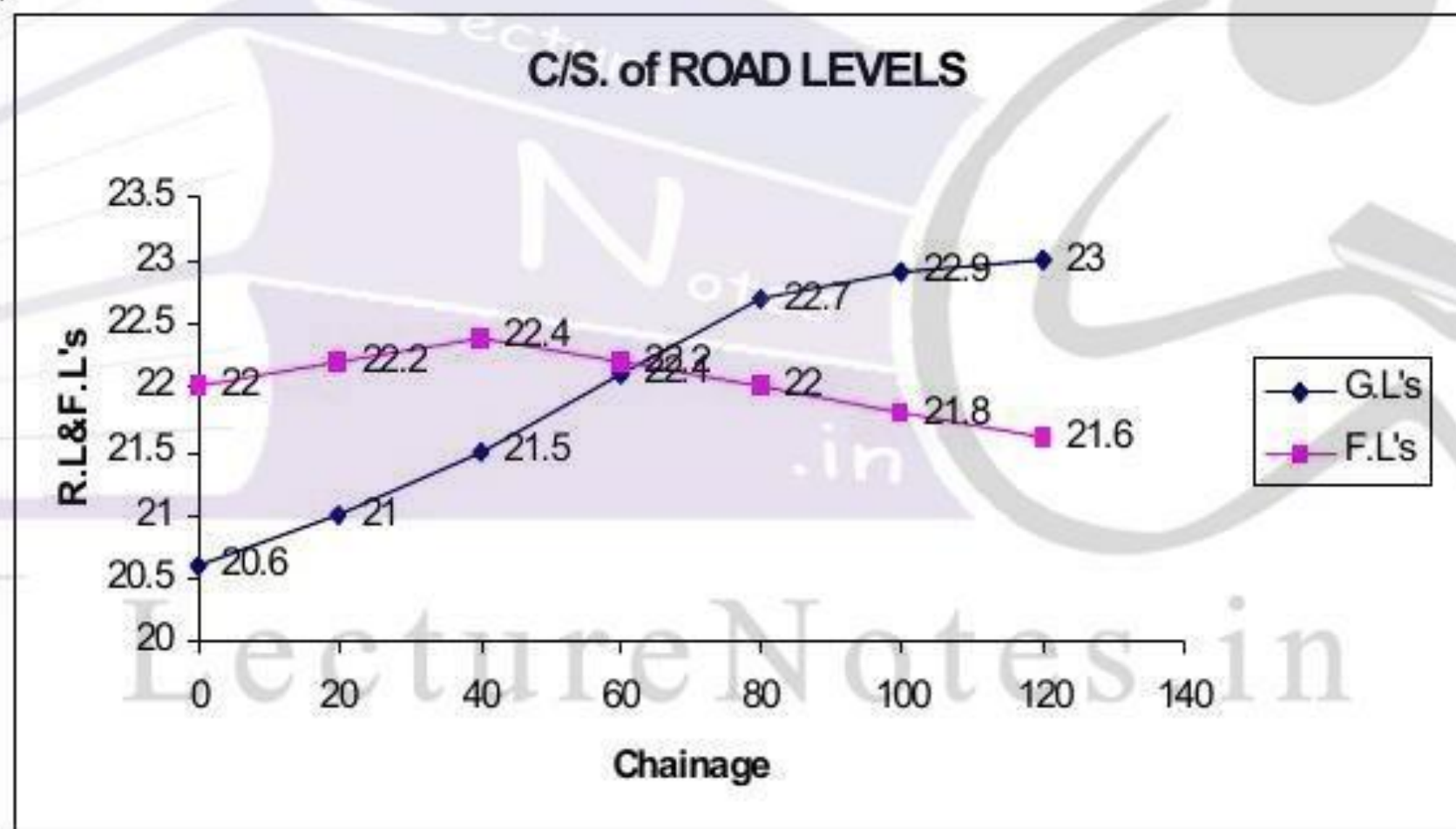

From similar triangel properties

$$\begin{aligned} \frac{x}{0.1} &= \frac{20-x}{0.7} \\ 0.7x &= (20-x)0.1 \\ 0.7x &= 2-0.1x \\ 0.7x+0.1x &= 2 \\ 0.8x &= 2 \\ x &= \frac{2}{0.8} = \frac{20}{8} = 2.5 \end{aligned}$$

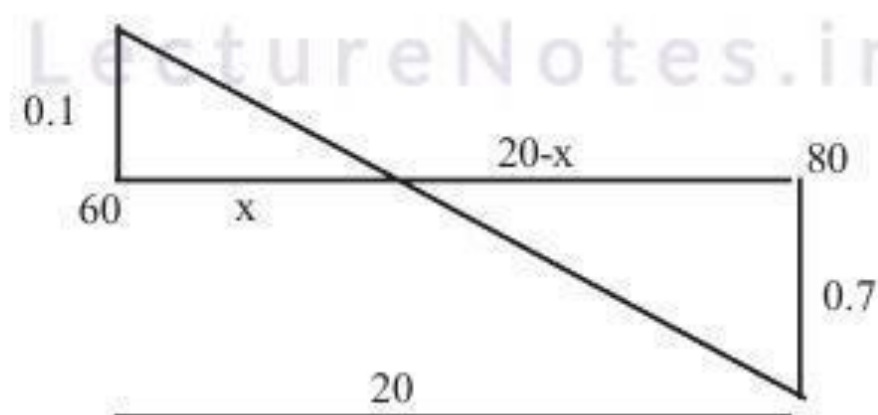

Earth work Calculations

94

vol of earth work in embankment

Chainage	0	20	40	60	62.5
Area	19.74	16.56	12.01	1.215	0.00

here the intervals are not equal so we have to take the separate volumes from 0th chainage to 60th chainage and 60th chainage to 62.5 chainage

$$\begin{aligned}V &= \text{Vol}(0-60) + \text{vol}(60-62.5) \\ &= 20 \left[\left(\frac{19.74 + 1.215}{2} \right) + (16.56 + 12.01) \right] + 2.5 \left[\frac{1.215 + 0.00}{2} \right] \\ &= 782.46 \text{m}^3\end{aligned}$$

By Prismoidal

$$\begin{aligned}V &= \frac{20}{3} [(19.74 + 1.215) + 4 \times 16.56 + 2 \times 12.01] + \frac{2.5}{3} [(1.215 + 0.00)] \\ &= 742.44 \text{ m}^3\end{aligned}$$

Vol of earth work in cutting

Chainage	62.5	80	100	120
Area	0.00	9.135	15.015	19.74

Volume (v) = vol (62.5-80) + Vol (80-120)

By Tripezoidal formula

$$\begin{aligned}V &= 17.5 \left[\frac{0 + 9.135}{2} \right] + 20 \left[\left(\frac{9.135 + 19.74}{2} \right) + 15.015 \right] \\ &= 668.98 \text{m}^3\end{aligned}$$

By Prismoidal

$$\begin{aligned}v &= \frac{17.5}{3} [0.9 + 135] + \frac{20}{3} [(9.135 + 19.74) + 4 \times 15.015] \\ &= 646.18 \text{ m}^3\end{aligned}$$

EXERCISE**Short Answer Questions**

- State the following formulae with usual notation
 - Prismoidal formula
 - Trapezoidal formula
- For an embankment 90m long of uniform gradient when the height of bank is 2.4m at one end and 1.8m at the other end the width of embankment at top is 8m and its side slopes 2 vertical to 1 Horizontal calculate the quantity of earth work by a) Mid Sectional area method b) Mean sectional area method.
- Find the earthwork in embankment between 5/2km to 5/5km of the proposed road whose c/s is given below.

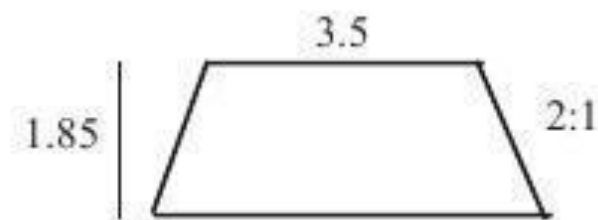
**Essay type questions**

- The road has the following data

Chainage in m	0	30	60	90	120
G.L. in m	25.8	26.5	27.2	28.1	28.5

The Formation level at chainage zero is 28 and having the rising gradient of 1 in 100 the top width is 10m and the side slopes are $1\frac{1}{2}$ horizontal to 1 vertical Assuming transverse slope is level calculate the volume of earth work.

- The reduced level of ground along the centre line of a proposed road from chainage 0 to 6 are given below. The formation level at '0' chainage is 10.00 and the road is in down ward gradient of 1 in 100 formation width of road is 10m and side slopes are 2:1 for both banking and cutting. Length of chain is 20m calculate the quantity of earth work required by a) Trapezoidal rule b) Prismoidal rule.

Chainage	0	1	2	3	4	5	6
RL of ground	8.0	7.8	7.6	7.3	6.9	6.2	6.5

Chapter

8

DETAILED ESTIMATES

A) Gravel Road

A gravel road comprising of a gravel of thickness 100mm compacted thickness and compacted by hand roller. A gravel is placed over an earthen formation which is compacted by a 2 tonne roller.

The estimate of gravel road consists of determining the following quantities.

- i) Earth work excavation and depositing on bank and compaction
- ii) collection of gravel
- iii) spreading compacting gravel to OMC

Example 8.1:- Find the estimation of a gravel road for the fig shown below. for a proposed road from 0km to 12km.

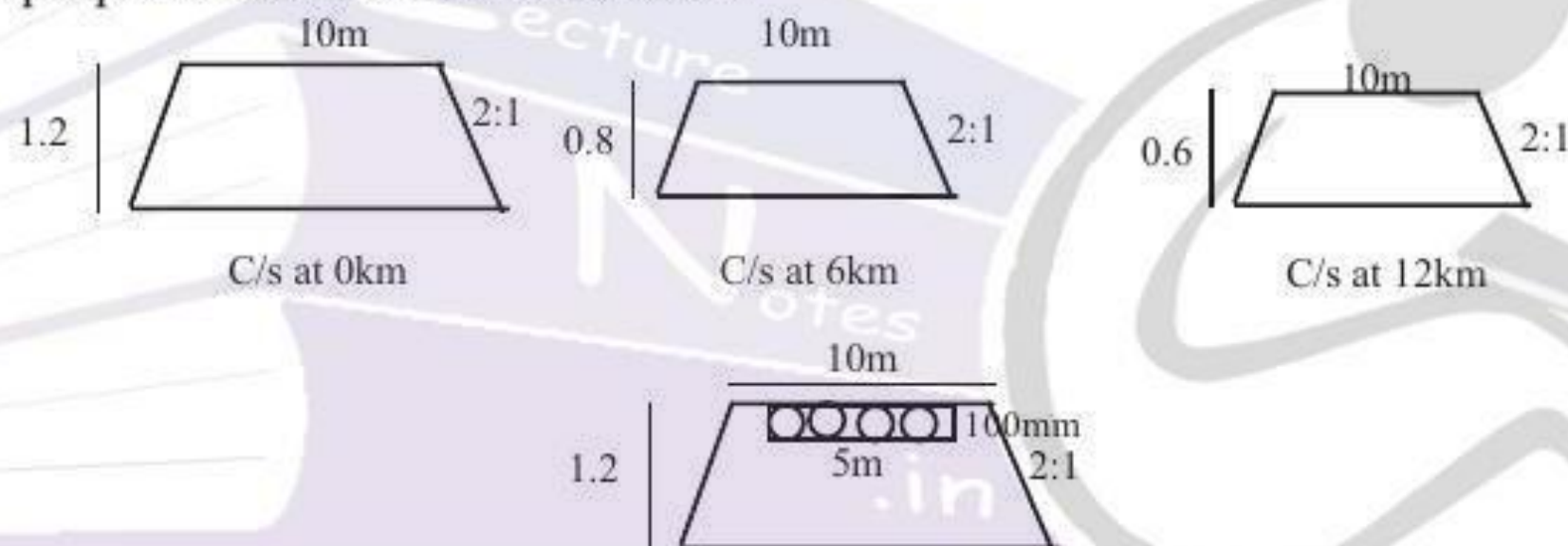

S.No.	Particulars of Items	No.	L	B	H	Q	Explanation
1	a) Earth work excavation and depositing on bank with an initial lead and lift of soil for formation and filling of pits, pot holes etc.						
	Area of C/s at 0 km (A) = $10 \times 1.2 + 2 \times 1.2^2 = 14.88 \text{m}^2$						
	Area of C/s at 6 Km (A2) = $10 \times 0.8 + 2 \times 0.8^2 = 9.28 \text{m}^2$						
	Area of C/s. at 12 km (A3) = $10 \times 0.6 + 2 \times 0.6^2 = 6.72 \text{m}^2$						
	Vol of earth work = $600 \left[\left(\frac{14.88 + 6.72}{2} \right) + 9.28 \right]$						= 12048m ³
	b) Add extra for pits & pot holes LS						= 52m ³
	Total						<u>12100 m³</u>
	Deduct for gravel = $1 \times 1200 \times 5 \times 0.1 = 600 \text{m}^3$						
	Net Earth work = $12100 - 600 = 11,500 \text{m}^3$						

2.	Collection of gravel including cost & conveyance etc complete 50% allowance is given for OMC compaction.	1	1200	5.00	0.15	900m ³	
3.	Spreading of gravel and watering	1	1200	5.00	---	6000m ²	
4.	Un forcean items @2%					L.S.	
5.	Tools and plant @1%					L.S.	
6.	P.S. and continsecis @4%					L.S.	

Cement concrete road

C.C. road is laid over an existing W.B.M road, In certain cases. It is laid over a prepared sub grade and a base course is provided. The concrete used for roads is M15 grade using 20mm H.B.G. metal while for base course a concrete of 1:4:8 using 40mm HBGmetal the stages of Estimations of a C.C.road is

- Earth work excavation and deposing on the bank
- Cement concrete (1:4:8) for base course
- Cement concrete (1:2:8) for wearing course.

Example 8.2:- Calculation for the estimation of a C.C.road for a length of 100m and width of C.C.road is 3.50m with 100mm thickness of earh layer.

S.No.	Particulars of Items	No.	L	B	H	Q	Explanation
1	C.C.(1:4:8) for base course including cost and conveyance of all materials at site machine mixing, laying curing etc.	1	100	3.5	0.1	35. cum	
2	C.C.(1:2:4) for pavement	1	100	3.5	0.1	35cum	
3	Provision for mastic pads					L.S.	
4	Unforcean items @2%					L.S.	
5	Petty supervision @4%					L.S.	

Example 8.3 :- Prepare an estimate for 1 Km length of C.C. track or the fig shown below.

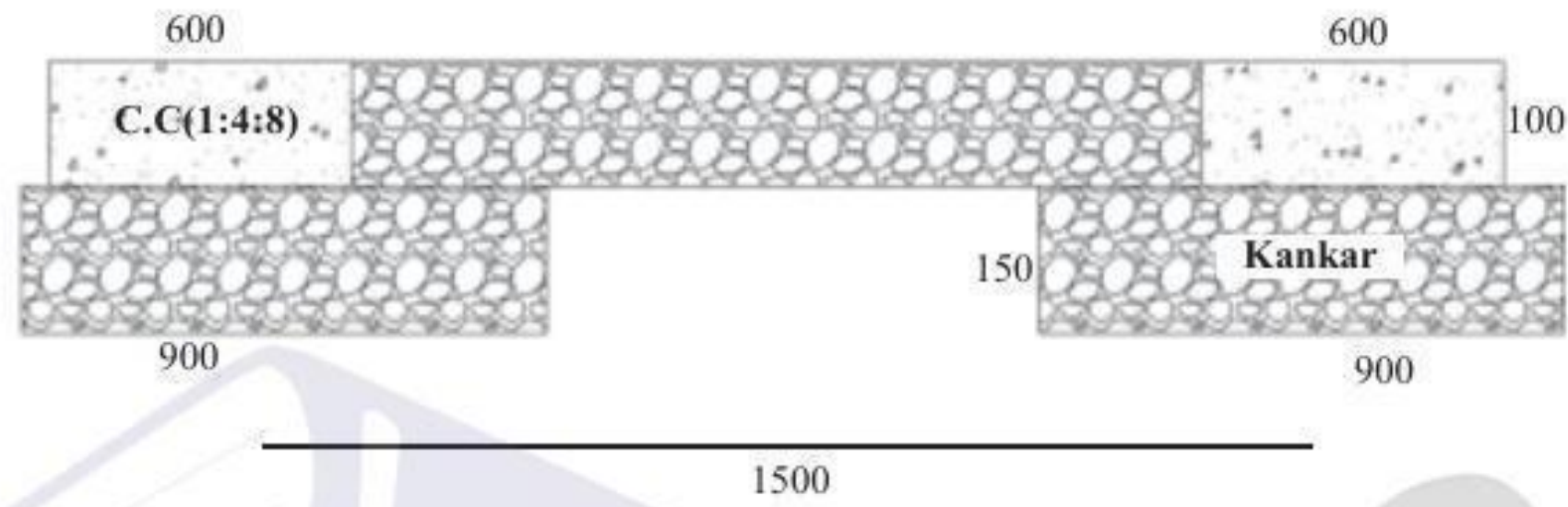



S.No.	Particulars of Items	No.	L	B	H	Q	Explanation
1	C.C.(1:2:4) in tracks including laying	2	1000	0.6	0.1	120m ³	
2.	laying of kankar (for loose thickness increase with 33 1/3%)						
	a) in between C.C.tracks	1	1000	0.9	0.133	120	
	b) under C.C.tracks	2	1000	0.9	0.20	360	
						480 m ³	

Example 8.4:- Calculate the quantities of different items of the figure shown in below

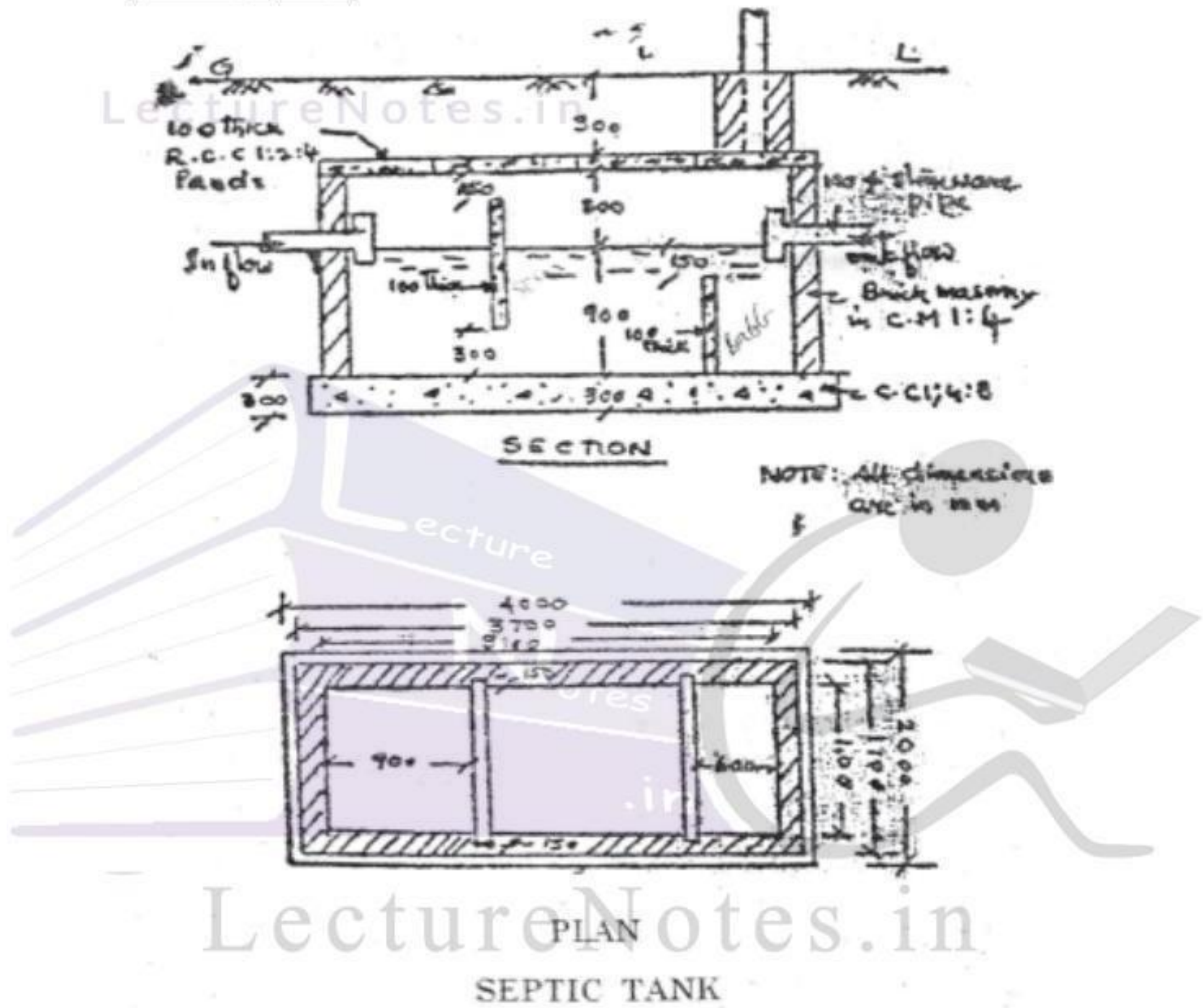
SEPTIC TANK

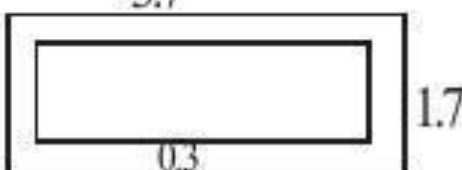

S.No.	Particulars of Items	No.	L	B	H	Q	Explanation
1	Earth work excation upto GL.	1	4.0	2.0	1.9	15.2m ³	
2.	C.C. (1:4:8) bed	1	4.0	2.0	0.3	2.4m ³	
3.	Brick masonry in CM 1:4 for side walls						
							
	Long wall short wall method						
	Long wall	2	3.7	0.3	1.2	2.664	
	Shortwalls	2	1.1	0.3	1.2	0.792	
	(or) Total					3.456	
	centre line method						
							
	total centre line length (3400+1400)2=9600	1	9.6	0.3	1.2	3.456	
4	R.C.C. (1:2:4) using 20mm HBG metal						
	a) R.C.C slab		3.70	1.70	0.1	0.629	
	b) Baffle wall		1.40	0.1	0.75	0.105	
	c) Scum board		1.40	0.1	0.75	0.105	
	Total					0.839	
5.	Plastering with CM(1:4) with 20mm th						
	a) Inner surface of septic tank		8.40	---	1.2	10.08	(3.1+1.1)2=8.4
	b) flooring		3.1	1.1	--	3.41	
	c) Sides of Scum board	1x2	1.1	--	0.75	1.65	
	d) Top and bottom	1x2	1.1	0.1	--	0.22	
	e) sides of baffle wall	1x2	1.0	--	0.75	1.65	
	f) top of baffle wall	1x1	1.0	0.1	---	0.1	
	Deduct for Pipe openings	2	$\frac{\pi}{4} \times (0.1)^2$			0.0157	
	Total (net) Plastering					17.10	

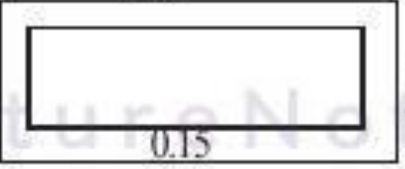
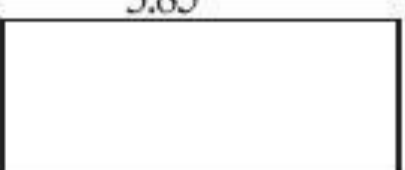



S.No.	Particulars of Items	No.	L	B	H	Q	Explanation
6.	a) Earth filling with excavated soil around the brick wall <div style="text-align: center;">  </div> centre line method <div style="text-align: center;">  </div> Total Centre line length = $(1.85+3.85)2=11.4$	1	11.4	0.15	1.30	2.223	
	b) over R.C.C. pannels (neglecting the space for venti pipe footing)	1	3.70	1.70	0.30	1.1887	
					Total	4.11	
7	supply fixing of steel grills including labour for fabrication @ 750N/m ³	1	0.839	x750=	6292N	62.92 Kgs	
8	Provision of 100mm dia inlet and out let tees	1x2	---	--	--	2Nos	
9.	Provision of A.C. ventilating shaft 3m high duly embedded in b/w at bottom	1x1			1 No	1 No	
10	Provision for A.C.cowl for ventilating pipe	1x1			1nos	1 No	
11	Unforcean itsm @2x				L.S	L.S	
12	P.S.& contingencies @4%				L.S	L.S	

LectureNotes.in

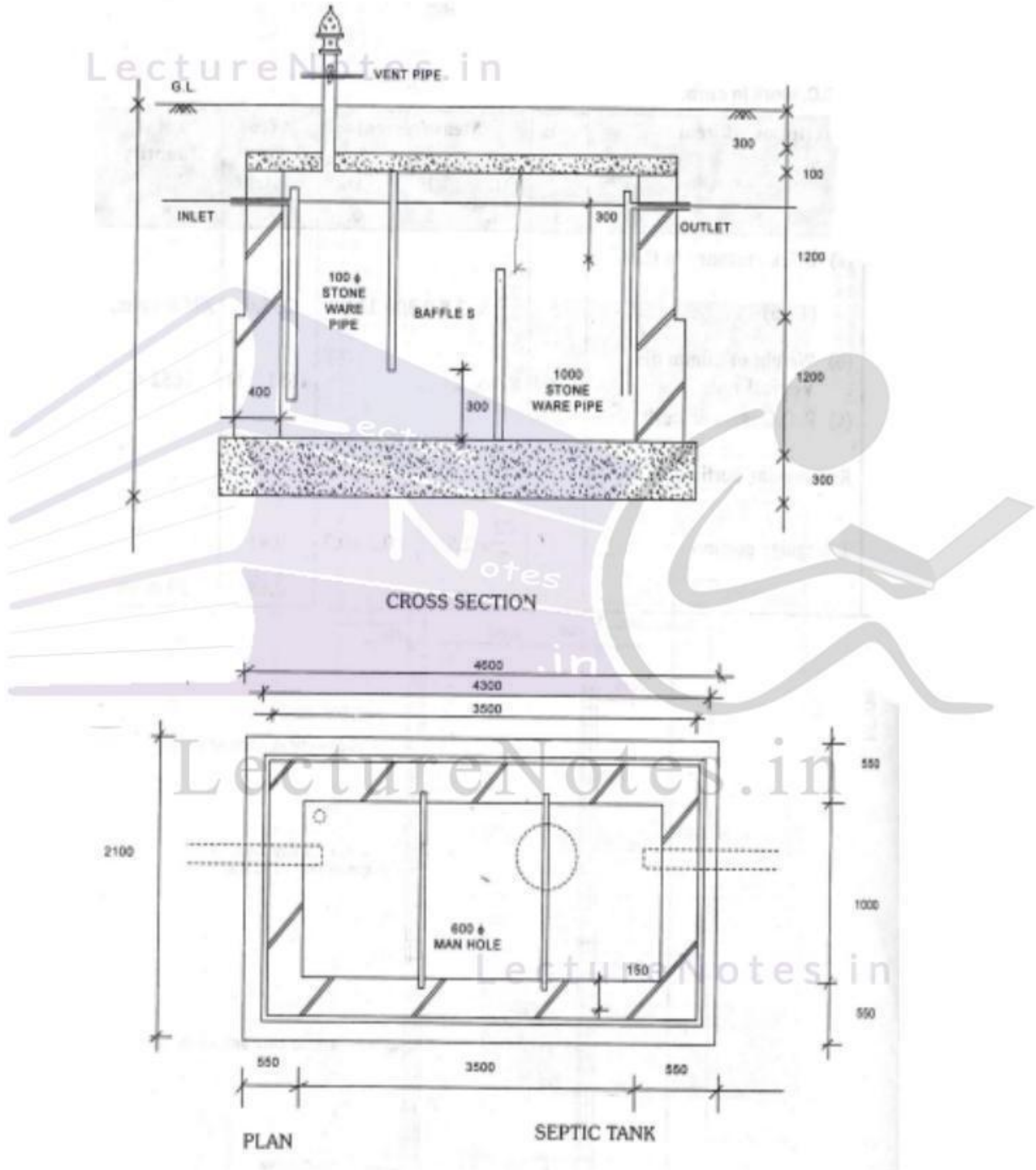
Example 8.5:- Calculate the quantities of different items of the figure shown in below

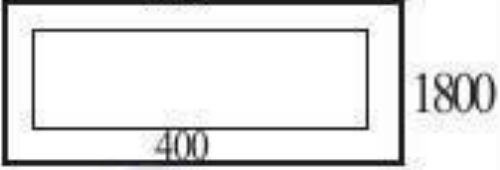
SEPTIK TANK

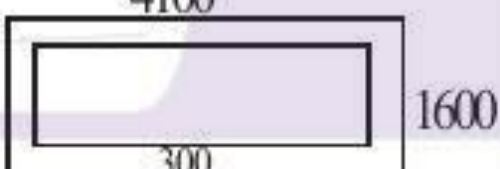

S.No.	Particulars of Items	No.	L	B	H	Q	Explanation
1.	Earth work excavation upto GL.	1	4.60	2.10	3.1	29.95	
2.	C.C.(1:4:8) bed for foundation	1	4.6	2.10	0.30	2.898	
3.	Brick masonry in CM 1:4 for side walls a) Upto first step (400th)						
							
	centre line method 3900	1	10.60	0.40	1.20	5.088	
							
	total centre line length =(3900+1400)2=10600						
	b) from Ist to II step (300th)						
							
	Centre line method 3800						
							
	Total centre line length (3800+1300)2=10200	1	10.20	0.3	1.20	3.672	
	Total Brick Masonry					= 5.088+3.672 = 8.76	
4.	R.C.C. (1:2:4) using 20mm HBG metal						
	a) RCC roof slab	1	4.10	1.60	0.1	0.656	(Assure projection
	b) Baffle wall	1	1.20	0.10	1.80	0.216	100mm inside the
	c) Scum ward	1	1.20	0.10	2.10	0.252	wall)
					Total	1.124	



S.No.	Particulars of Items	No.	L	B	H	Q	Explanation
5.	Plastering with CM(1:4) with 20mm thick						
	a) Inner surface of septic tank	1	9.0	--	2.4	21.6	L=2(3.5+1.0)=9.0
	b) flooring	1	3.5	1.0	--	3.15	
	c) sides of scum board	1x2	1.0	--	2.1	4.2	
	d) Bottom of scum board	1	1.0	0.1	---	0.1	
	e) sides of baffle wall	1x2	1.0	---	1.8	3.6	
	f) Top of baffle wall	1	1.0	0.1	--	0.10	
	g) deduction for Pipe opening	2	$\frac{\pi \times (0.1)^2}{4}$			-0.015	
						33.08	Net Plastering = 33.08 m ²
6.	Earth filling with excavated soil around the brick work						
	a) upto first step						
				1.60			
	Total length = (4.45+1.95)2 = 12.8	12.80	0.15	1.2		2.304	
	b) from 1st step to up to Ground Level						
				1x2			
				1x1			
	Total Centre Line length = 2(4.35+1.85) = 12.4	1	12.40	0.25	1.60	4.96	

S.No.	Particulars of Items	No.	L	B	H	Q	Explanation
7	Supply & fixing of steel grills including labour for fabrication @750 N/m ³	1				L.S	
8	Provision of 100mm dia inlet & outlet Tees	1x2	---	----	---	2Nos	
9	Provision of A.C. cowl for ventilating shaft 3 mt height duly embedded below at bottom	1x1	--	--	--	1No	
10	Provision of A.C. cowl for ventilating pipe	1x1	--	--	--	1 No	
11	Unforceen items @2x					L.S	
12	R.S.& Contingeties @4%					L.S	

Example 8.6:- Calculate the quantities of different items of the figure shown in below

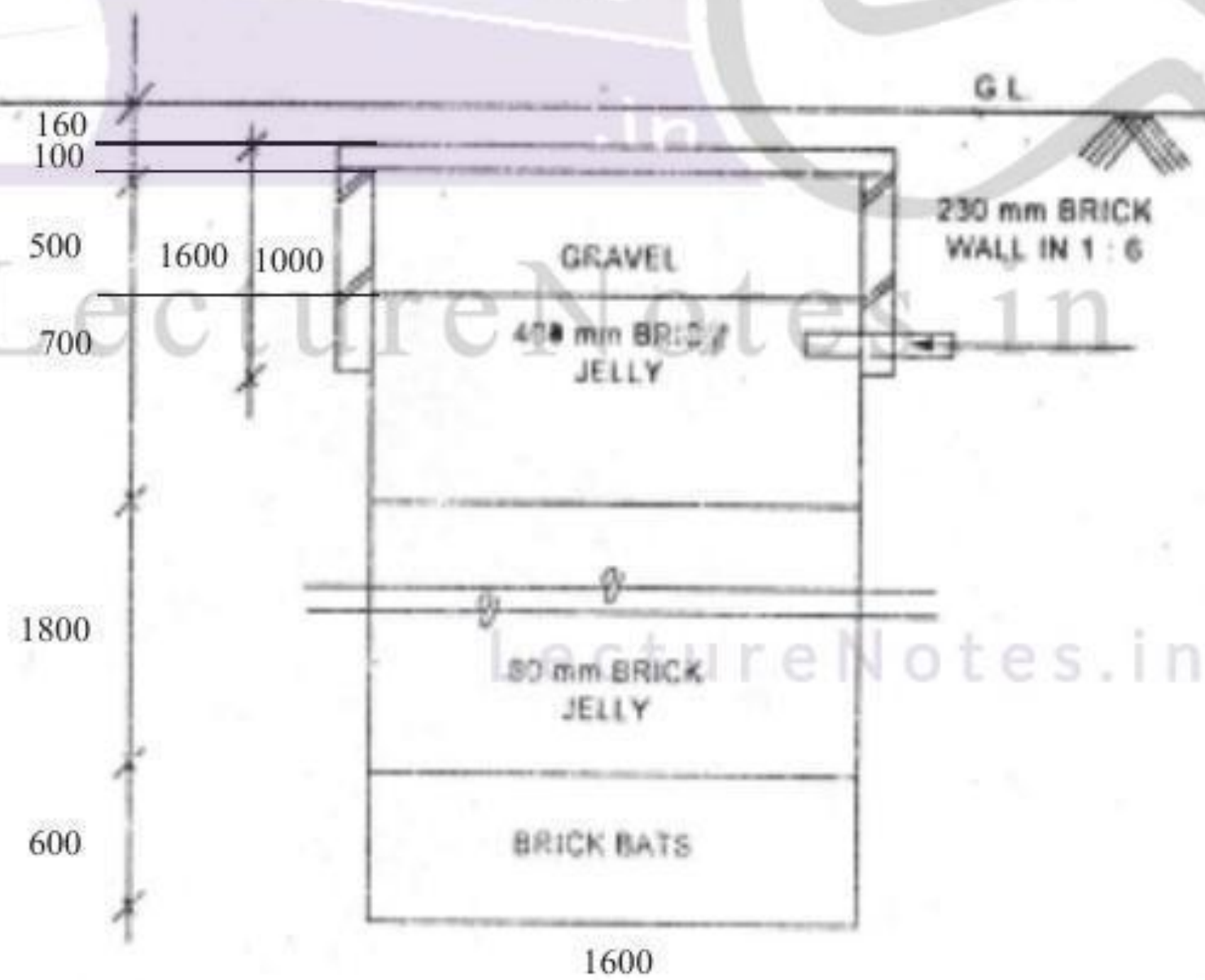
SOAK PIT

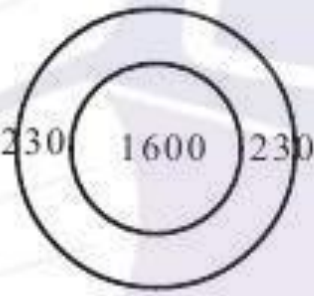

S.No.	Particulars of Items	No.	L	B	H	Q	Explanation
1.	Earth work excavation in non cohesive soils like sandy soils with an initial lead & lift						
	a) Soak pit	1	$\frac{\pi}{4} \times 1.6^2$		3.86	7.76	
	b) side brick wall	1	$\frac{\pi}{4} (2.06^2 - 1.6^2)$		1.16	1.53	
					Total	9.29	
2.	Brick work in CM(1:5) with country bricks including cost and conveyance etc complete around the pit						
	 centre line method	1	$\frac{\pi}{4} (2.06^2 - 1.6^2)$	0.9		1.19	
		1	$\pi (1.83)$	0.23	0.9	1.19	
3.	supply & packing including cost & conveyance						
	a) Brick bats	1	$\frac{\pi}{4} \times 1.6^2$		0.6	1.2	
	b) 80mm brick jelly	1	$\frac{\pi}{4} \times 1.6^2$		1.8	3.62	
	c) 40mm brick jelly	1	$\frac{\pi}{4} \times 1.6^2$		0.7	1.4	
	d) gravel brick jelly	1	$\frac{\pi}{4} \times 1.6^2$		0.5	1.00	
					Total	7.22	
4.	R.C.C.(1:2:4) slab panels (precast) using 20mm HBG metal including cost & conveyance	1	$\frac{\pi}{4} \times 2.06^2$		0.1	0.33	
5.	Filling with clay soil on top of pit upto GL.	1	$\frac{\pi}{4} \times 2.06^2$		0.16	0.53	

$$\frac{\pi}{4} \times 1.6^2$$

$$\frac{\pi}{4} \times 1.6^2$$

S.No.	Particulars of Items	No.	L	B	H	Q	Explanation
7.	Laying of joining 100mm popies including earth work Encavation, sand filling packing joints etc complets $L=12+0.23+1.6/2$	1	13.03			13.03	RM
8	Unforcean items of work@2%	1	--			LS	
9	Petty supervision and contingencies@4%	1	---			LS	

EXERCISE

1. Calculate the quantities of various elements of the figure shown in below.

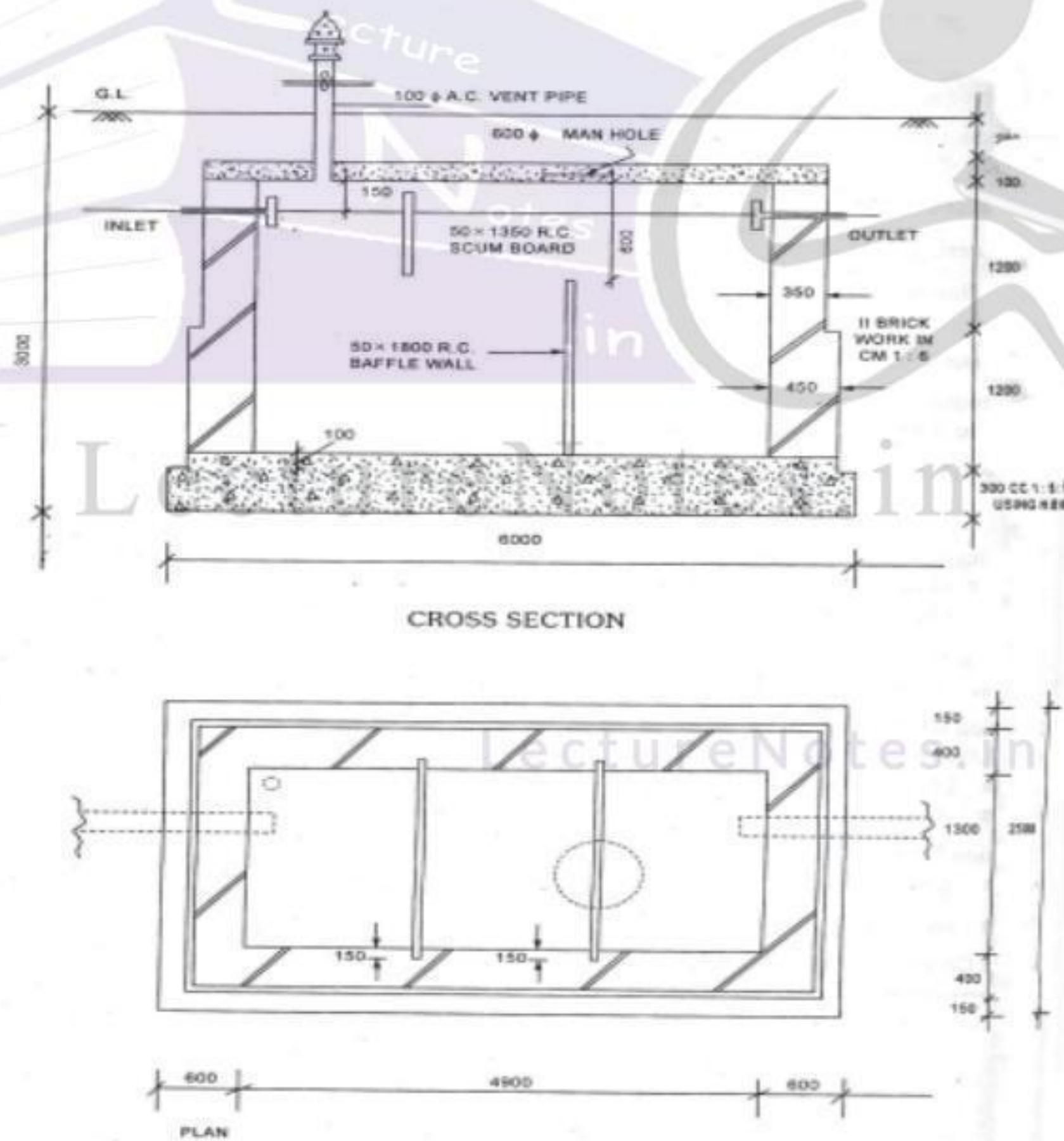

2. Prepare a detailed estimate for following items of work of "SOAKPIT" from the given figure
- a) 800mm size brick jelly.
 - b) 40mm size brick jelly.
 - c) Gravel,
 - d) Brick masonry in C.M. (1:6):

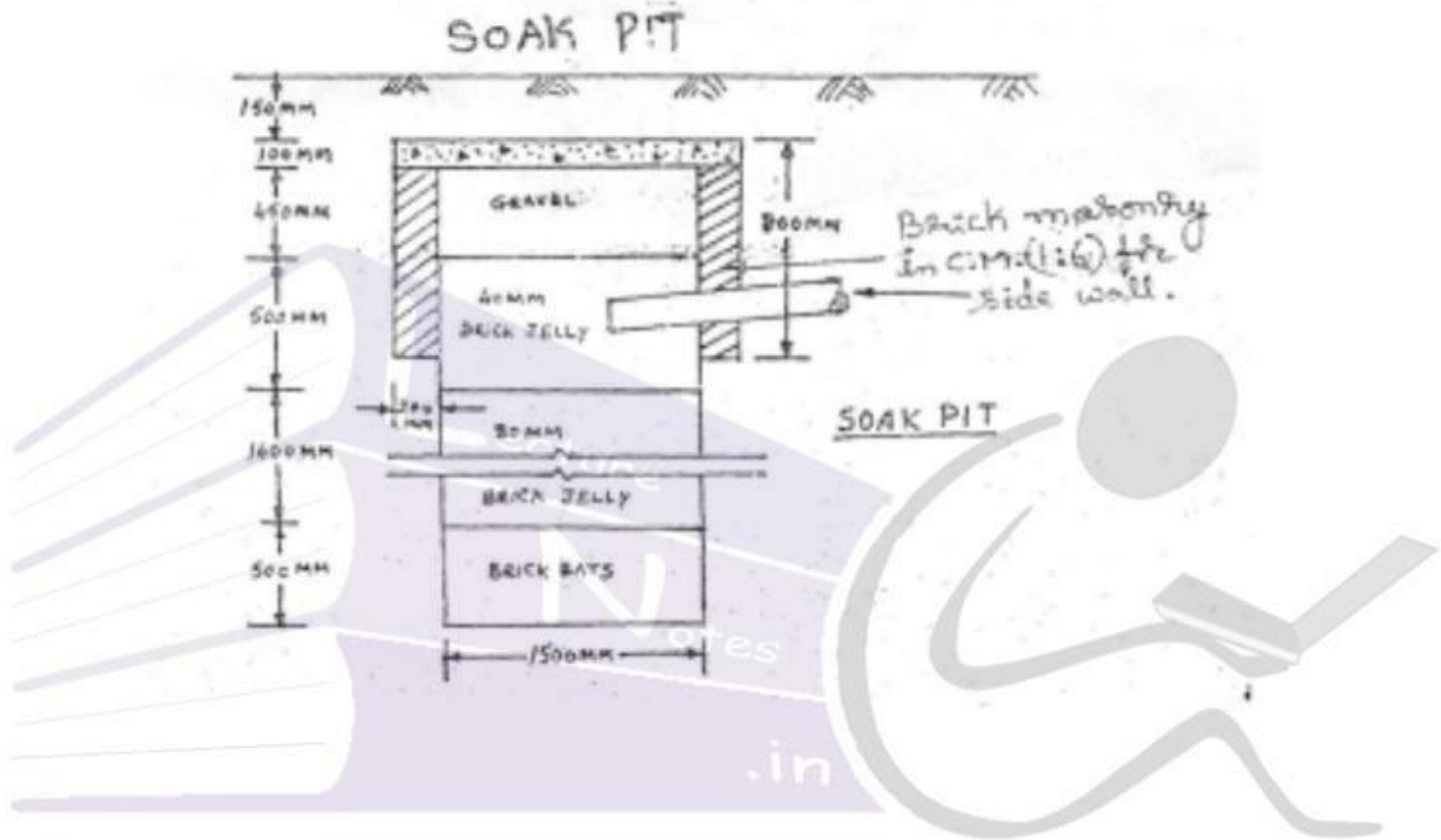

LectureNotes.in

LectureNotes.in

APPENDIX**Quantities of Materials and their Costs:**

This includes the quantities of various materials for unit quantity of an item followed by the specification and costs of various materials. The cost includes first cost, freight, transportation and insurance charges.

Labour and Cost:

This includes the number and wages of different categories of labourers. Skilled, unskilled etc.,

Cost of Equipment:

For big projects it is necessary to use special type of tools and plants like special type of mixed concrete transport vehicle called tripping wagons, cranes etc. in order to purchase such tools and plants and amount of 2 to 3% of estimated cost is provided in the estimate.

Over head Charges:

This includes office rent, depreciation of equipments, salaries of office staff, postage, lighting travelling allowances, telephone bills. The contractor may provide small tools like ladders, trowels, ropes etc., for his workmen. Here an amount of 5% of estimated cost is provided towards overhead charges.

Profit :

Generally 10% of estimated cost is considered for contractor's profit after allowing the charges of equipments and establishments. For small jobs 15% and large works 8% profit is considered.

Standard Data Book:

This book gives the quantities of materials and labour required for unit item of work.

Standard scheduled of rates:

The rates of materials and wages of labourers are fixed by superintending Engineer for this cycle for every year. And these rates are approved by board of engineers. The S.S.R. for 2002-2003 is presented in the last pages.

Water Charges:

For drinking and for works the arrangement of water is done either by sinking tube well or by giving connection to the work site from corporation by a pipe line. Centrally 1% of estimated.

Task or out-turn work:

This is the quantity of work which can be done by an artisan for trade working of 8 hours. Although the task is different from person to person according to their physical and mental abilities, the average task or out turn work is taken into consideration for preparing rate per unit item. Task does not mean that the quantity of work done by one labour. But other labourers also be engaged to complete the given task.

For example a mason can prepare 2.0m³ of cement concrete per day provided he is helped by two mazdoors to carry and mix the ingredients.

The following may be taken as approximate quantity of work out-turn work or task for an average artisan per day.

Sundries:

A lumpsum amount is generally provided in the analysis of rates, towards purchase of certain tools and other petty items which cannot be accounted in detail. an amount of 2½ to 3% of labour cost is provided for this purpose.

TABLE

No.	Description of work	Quantity of work per day (8 hours of day)
1.	Earth work excavation in foundation, trenches in ordinary soils, lead 50m and lift up to 1.5m	2.75 m ³ /Mazd
2.	Earth work in excavation in foundation trenches in hard soils, lead 50m and lift upto 1.5m	2.10m ³ / Mazd
3.	Earth work in soft or decomposed rock by blasting lead up to 50m and lift upto 1.5m	0.55m ³ / MaZd
4.	Sand filling in plinth, consolidation and dressend	4.0m ³ / Mazd
5.	Single layer brick flat soling including ramming, dresing etc.	9.0Sqm/ Mazd
6.	Lime concrete in foundation	10m ³ /Mason
7.	C.C.	4.0m ³ / Mason
8.	R.C.C. (1:2:4)	3.25m ³ / Mason
9.	Brick work in foundation and plinth	1.40m ³ /Mason
10	Brick work in super structure (G.F)	1.25m ³ /Mason
11	Half brick work in partition wall	7.00Sqm/ Mason

12	Bricks in plain arches	1.0m ³ / Mason
13	Reinforced brick work in slabs	1.00m ³ / Mason
14	2.5 cm C.c.D. P.C.	12.5 m ² /Mason
15	2.0cm D.P.C. with C.M.	20Sqm/ Mason
16	R.R.Masonry foundation & Plinth	1.00cm/Mason
17	R.R.Masonry in superstructure	0.9m ³ / Mason
18	Ashlar masonry in superstructure	0.40m ²
19	C.R.S. Masonry in superstructure	0.67m ²
20	Brick on 1st floor with C.M.	1.0 Sqm/ Mason
21	7.5 cm floor with (1:4:8)	10.0Sqm/mason
22	Teraced flooring -7.5cm TH	20Sqn/mason
23	2.5cm THC.C. flooring	12.50 Sqm/mason
24	Terrazzo flooring 6mm TH mosaic work ove 2cm thick C.C.(1:2:4)	5.0 Sqm/m ²
25	Pre cast Terrazzo tiles 2mm TH, laying on bed of 25mm thick L.M.	5.0 Sq/m ²
26	Ranigang Tile roofing	6.7 Sqm
27	Mangaloe tile roofing including wooden battens, tiles set in C.M.	20 m ²
28	Corrugated G.I. sheet roofing	10Sqm
29	12mmTH current plaster on new brick work	10Sqm
30	Rule pointing on brick work	10Sqm
31	Single coat white washing over old white washing	133 Sqm
32	White washing over one coat printing	33.70 sqm
33	Lime pinning over interior surfaces(Plaster)	5.00sqm
34	Water proofing cement paint to new cement plaster	20.m ³ /Paints
35	Snow cem washing on plaster surface two coats	20 m ³ /sqm
36	Priming coat with ready mined primer on wood or steel	40m ³
37	Painting two coats with ready mined paint for wood work	18m ²
38	Breaking of over burnt brick to ballast 40mm down	0.75m ³ /Mazd
39	Breaking of over burnt brick to ballast 25mm	0.55m ³

PREAMBLE

1. AREA ALLOWANCES:

A. MUNICIPALITIES

- i) Allow 15% extra over basic rates on labour components works (upto a belt of 12k.m from the Municipal limits in all District Head Quarters for all special class, first class and the remaining Municipalities.
- ii) For works at Tirumala Hills 30% extra over the S.S.Rates and 30% extra for Hoarsely Hills over the S.S.Rates of (R&B) circle, CHITTOOR is allowed on labour component works.
- iii) For works located inside Tirumala Temple allow 20% extra over the rate for Tirumala Hills.

Note: For Items (i) above works within a belt of 12 Kilometers from all the Municipal limits shall be taken into account for purpose of allowing the extra percentage.

B. INDUSTRIAL AREA

10% extra over the basic rates on Labour component shall be allowed (upto a belt of 10km from the Municipal limits).

C. RURAL AREA

Allow 15% extra on skilled and semi skilled workmen in rural areas where no other allowances including importation of labour and amenities are admissible

D. AGENCY/TRIBAL AREA

Not applicable to this circle.

E. GHAT ROADS

For the Ghat roads steeper than 1 in 20 gradient, the length of the road may be taken as 1.50 times of the existing length of the road for the purpose of leads only for the conveyance of materials based on the certificate for the Ghat Road given by the Superintending Engineer concerned.

NOTE : Under the compelling circumstances the concerned Chief Engineer can adopt the equivalent length of the road at 2.5 times of the actual length.

F. JAIL COMPOUNDS

15% extra is allowed over labour rates for the works in the Jails compounds, only equivalent number of men mazdoors shall be provided for works in jail Premises as no women and Children are allowed inside.

NOTE: If more than one area allowance such as those for (a) Municipalities (b) Industrial area (c) Ghat Roads are applicable for a particular situation only the maximum out of the allowable percentage is to be allowed.

II. IMPORTATION OF LABOUR AND LABOUR AMENITIES:

Maximum of 13% towards labour importation and amenities to labour butting etc., of the total labour component is allowed only in case of works where the labour component (i.e.,) excluding the cost of materials such as cement and steel works out to more than Rs. 1.00 lakhs vide G.O. Ms. No. 270 T R&B(c-I0 Department dated: 20-5-1978 on the basis of certificate of the Executive Engineer that the local labour available is not adequate and that labour has to be imported for executing the work subject to the approval of the Chief Engineer Concerned.

NOTE:

1. Extra percentage towards Labour importation and labour amenities where ever necessary is admissible in addition to other percentages allowable.
2. The above percentages may be allowed where ever necessary on the following item.
 1. Labour Rates.
 2. Materials like Sand, Metal Kankar, Quarry rubbish and clay for foundation or filling etc., bricks and tiles.
 3. Jungle Clearance.
 4. Dismantling
 5. Earth work including leads and lifts.
 6. Purely labour involving items like grinding, mixing, binding, steel and feeding ingredients into mixer etc.,
 7. Blasting, Drilling holes etc.,
 8. Stacking metal, Sand, Gravel, Stone, Picking, metallised, gravelled surface spreading metal etc.,
 9. Loading and unloading materials excluding that parts of work in conveyance of materials by carts and lorries.
 10. Labour components to be included in the data for items like masonry, mortar etc.,

III. WATER LEAD

The following labour is allowed for conveyance of water for every half kilometer lead or part there over the initial lead or part there of over the initial lead of half Kilometer.

- a) Cement Concrete 1.50 Woman Mazdoor / cum.
- b) Masonry 1.60 Woman Mazdoor /cum.
- c) Plastering 0.50 Woman Mazdoor / 10sqm.

IV. EXCAVATION OF TRIAL TRENCHES, TRIAL PITS AND EXCAVATION IN RESTRICTED PLACES.

- a) Trial trenches not more than 2 Metres in width and depth not less than twice the Width -20% extra.
- b)
 - 1. Trial pits upto 2 M depth 125% extra
 - 2. Over 2M depth and upto 4M depth 200% extra
 - 3. Over 4M depth and upto 6M depth 300% extra
 - 4. Over 6M depth and upto 8M depth 400% extra
 - 5. Over 8M depth and upto 9M depth 400% extra
 - 6. Over 9M depth 550% extra
- c) Excavation in Restricted places:
 - i) Foundation of building, excavation of road boundary drains, model sections for canals, excavation of field channels excavation of narrow trenches of similar nature not more than 2M in width and depth not less than twice the width.
 - 50% Extra
 - ii) For pipe lines where the depth is less than 1.5times 75% Extra the width
 - iii) For pipe lines where the depth is 1.5 times or more than the width 150%Extra
 - iv) Silt removal in restricted area such as channels of under tunnels, culverts and syphons. 150% Extra

NOTE :

- i) The extra percentage allowed is over S.s., 301 rates for the corresponding soil, it includes the charges of all lifts and initial lead but do not include dewatering charges if any in respect of all the items under (a) & (b) above.
- ii) The above extra percentage in respect of excavation in restricted places are not to be allowed in respect of items involving blasting component which is to be taken as 1/3 of the cost.

V. PROVISIONS OF 1st CLASS AND 2nd CLASS WORK MEN UNDER SKILLED LABOUR

30% of the skilled labour provided in the data may be taken as 1st Class and remaining 70% as 2nd class.

Where the nature of work is same no distinction need be made in case of men and women workers.

VI. CEMENT CONCRETE PROPORTION AND REQUIREMENTS TO COARSE AGGREGATES ETC.,(UNIT=1cum)OF FINISHED WORK

- i) For Cement Concrete proportions (1:4:8) (1:5:10) etc. 0.92 cum of coarse aggregate shall be adopted and the quantity of mortar required calculated proportionately in each case.
- ii) For Cement concrete proportions (1:5:8) (1:6:10) etc., 0.90 cum of coarse aggregate shall be adopted and the quantity of mortar required calculated proportionately in each case.

VII. REQUIREMENTS OF CEMENT MORTAR FOR STONE MASONRY

Per unit (1cum) of finished work:

- | | | |
|---------------------------|---|---------------------------|
| a) CR. Masonry first sort | - | 0.28 cum of Cement mortar |
| b) CR.Masonry second sort | - | 0.32 cum of Cement mortar |
| c) R.R.Masonry | - | 0.34 cum of Cement mortar |

NOTE: In massive walls above 3M thick, 0.40cum of cement mortar shall be allowed.

VIII. REVETMENT AND APRON WORKS

- i) The size of stone for the volume range 0.0515 to 0.030 cum shall not be less than 0.30 x 0.30 x 0.15M to 0.30x 0.225 x 0.225M.
- ii) The rate of labour components as per the standard Data book is to be adopted for revetment work only. However for apron work Rs. 2.50 per cum should be deducted.
- iii) Labour charges for rock to be adopt two thirds of the labour charges of revetment item.

IX. SEIGNIORAGE CHARGES

- i) The seigniorage charges as existing actually may be added in the Data rates in the estimates subject to the conditions that the concerned Executive Engineer who prepare the estimates should certify in writing the rates of seigniorage charges in all cases where the seigniorage charges are actually payable.
- ii) The revised seigniorage charges as fixed by Government in G.O.M.S. No.154 (Industries and commerce(M-I) Department Dt. 23-07-96 may be adopted as follows.