

C.V. RAMAN POLYTECHNIC, BHUBANESWAR



C.V.Raman Polytechnic
Quality Education for the New Millenium

LECTURE NOTE

CONCRETE TECHNOLOGY (Th-4)

SEM-6TH

BRANCH-CIVIL ENGINEERING

Prepared by

SAFALYA MOHANTY

(Asst. Prof. in Civil Engineering)

Concrete technology

Unit 1- Introduction

Definition of concrete:

Concrete is the most commonly used man-made material on earth. It is an important construction material used extensively in buildings, bridges, roads and dams. Its uses range from structural applications, to kerbs, pipes and drains.

Concrete is a mixture of binding material, aggregates and water in a definite proportion.

1. Types of concrete:

1. Cement concrete: It is a mixture of cement, fine aggregates, coarse aggregates and water in a definite proportion.
2. Lime concrete: Here binding material is lime (CaO)
3. RCC: Steel reinforcing is done in the Cement Concrete.
4. Prestressed cement concrete:

This concrete is a form of concrete used in construction which is "pre-stressed" by being placed under compression prior to supporting any loads beyond its own dead weight. This compression is produced by the tensioning of high-strength "tendons" located within or adjacent to the concrete volume, and is done to improve the performance of the concrete in service.

2. Uses of concrete:

Many structural elements like footings, columns, beams, chejjas, lintels, roofs are made with R.C.C. Cement concrete is used for making storage structures like water tanks, bins, silos, bunkers etc. Bridges, dams, retaining walls are R.C.C. structures in which concrete is the major ingredient storage structures like water tanks, bins, silos, bunkers etc.

3. Benefits of concrete:

There are numerous positive aspects of concrete:

1. It is a relatively cheap material and has a relatively long life with few maintenance requirements.
2. It is strong in compression.

3. Before it hardens it is a very pliable substance that can easily be shaped.
4. It is non-combustible.

4. Limitations of concrete:

The limitations of concrete include:

1. Relatively low tensile strength when compared to other building materials.
2. Low ductility.
3. Low strength-to-weight ratio.
4. It is susceptible to cracking.

Unit 2

Ingredients of concrete

A. **Cement:** cement is a binding material used in the masonry.

Physical Properties of Cement

Different blends of cement used in construction are characterized by their physical properties. Some key parameters control the quality of cement. The physical properties of good cement are based on:

Fineness of cement

Soundness

Consistency

Strength

Setting time

Heat of hydration

Loss of ignition

Bulk density

Specific gravity (Relative density)

These physical properties are discussed in details in the following segment. Also, you will find the test names associated with these physical properties.

1. Fineness of Cement

The size of the particles of the cement is its fineness. The required fineness of good cement is achieved through grinding the clinker in the last step of cement production process. As hydration rate of cement is directly related to the cement particle size, fineness of cement is very important.

2. Soundness of Cement

refers to the ability of cement to not shrink upon hardening. Good quality cement retains its volume after setting without delayed expansion, which is caused by excessive free lime and magnesia.

Tests: Unsoundness of cement may appear after several years, so tests for ensuring soundness must be able to determine that potential.

Le Chatelier Test

This method, done by using Le Chatelier Apparatus, tests the expansion of cement due to lime. Cement paste (normal consistency) is taken between glass slides and submerged in water for 24 hours at $20 \pm 1^\circ\text{C}$. It is taken out to measure the distance between the indicators and then returned under water, brought to boil in 25-30 mins and boiled for an hour. After cooling the device, the distance between indicator points is measured again. In a good quality cement, the distance should not exceed 10 mm.

3. Consistency of Cement

The ability of cement paste to flow is consistency.

It is measured by Vicat Test.

In Vicat Test Cement paste of normal consistency is taken in the Vicat Apparatus. The plunger of the apparatus is brought down to touch the top surface of the cement. The plunger will penetrate the cement up to a certain depth depending on the consistency. A cement is said to have a normal consistency when the plunger penetrates 10 ± 1 mm.

4. Strength of cement

Three types of strength of cement are measured – compressive, tensile and flexural. Various factors affect the strength, such as water-cement ratio, cement-fine aggregate ratio, curing conditions, size and shape of a specimen, the manner of molding and mixing, loading conditions and age. While testing the strength, the following should be considered:

Cement mortar strength and cement concrete strength are not directly related. Cement strength is merely a quality control measure.

The tests of strength are performed on cement mortar mix, not on cement paste.

Cement gains strength over time, so the specific time of performing the test should be mentioned.

5. Compressive Strength

It is the most common strength test. A test specimen (50mm) is taken and subjected to a compressive load until failure. The loading sequence must be within 20 seconds and 80 seconds.

Tensile strength

Though this test used to be common during the early years of cement production, now it does not offer any useful information about the properties of cement.

Flexural strength

This is actually a measure of tensile strength in bending. The test is performed in a 40 x 40 x 160 mm cement mortar beam, which is loaded at its center point until failure.

Standard test: ASTM C 348: Flexural Strength of Hydraulic Cement Mortars

6. Setting Time of Cement

Cement sets and hardens when water is added. This setting time can vary depending on multiple factors, such as fineness of cement, cement-water ratio, chemical content, and admixtures. Cement used in construction should have an initial setting time that is not too low and a final setting time not too high. Hence, two setting times are measured:

Initial set: When the paste begins to stiffen noticeably (typically occurs within 30-45 minutes) Final set: When the cement hardens, being able to sustain some load (occurs below 10 hours) Again, setting time can also be an indicator of hydration rate.

Standard Tests:

AASHTO T 131 and ASTM C 191: Time of Setting of Hydraulic Cement by Vicat Needle AASHTO T 154: Time of Setting of Hydraulic Cement by Gillmore Needles

ASTM C 266: Time of Setting of Hydraulic-Cement Paste by Gillmore Needles

7. Heat of Hydration

When water is added to cement, the reaction that takes place is called hydration. Hydration generates heat, which can affect the quality of the cement and also be beneficial in maintaining curing temperature during cold weather. On the other hand, when heat generation is high, especially in large structures, it may cause undesired stress. The heat of hydration is affected most by C3S and C3A present in cement, and also by water-cement ratio, fineness and curing temperature. The heat of hydration of Portland cement is calculated by determining the difference between the dry and the partially hydrated cement (obtained by comparing these at 7th and 28th days).

Standard Test: ASTM C 186: Heat of Hydration of Hydraulic Cement

8. Loss of Ignition

Heating a cement sample at 900 - 1000°C (that is, until a constant weight is obtained) causes weight loss. This loss of weight upon heating is calculated as loss of ignition. Improper and prolonged storage or adulteration during transport or transfer may lead to pre-hydration and carbonation, both of which might be indicated by increased loss of ignition.

Standard Test: AASHTO T 105 and ASTM C 114: Chemical Analysis of Hydraulic Cement

9. Bulk density

When cement is mixed with water, the water replaces areas where there would normally be air. Because of that, the bulk density of cement is not very important. Cement has a varying range of density depending on the cement composition percentage. The density of cement may be anywhere from 62 to 78 pounds per cubic foot.

10. Specific Gravity (Relative Density)

Specific gravity is generally used in mixture proportioning calculations. Portland cement has a specific gravity of 3.15, but other types of cement (for example, portland-blast-furnace-slag and portland-pozzolan cement) may have specific gravities of about 2.90.

Standard Test: AASHTO T 133 and ASTM C 188: Density of Hydraulic Cement

B. Chemical Properties of Cement

The raw materials for cement production are limestone (calcium), sand or clay (silicon), bauxite (aluminum) and iron ore, and may include shells, chalk, marl, shale, clay, blast furnace slag, slate. Chemical analysis of cement raw materials provides insight into the chemical properties of cement.

1 Tricalcium aluminate (C3A)

Low content of C3A makes the cement sulfate-resistant. Gypsum reduces the hydration of C3A, which liberates a lot of heat in the early stages of hydration. C3A does not provide any more than a little amount of strength.

Type I cement: contains up to 3.5% SO₃ (in cement having more than 8% C3A) Type II

cement: contains up to 3% SO₃ (in cement having less than 8% C3A)

2. Tricalcium silicate (C3S)

C3S causes rapid hydration as well as hardening and is responsible for the cement's early strength gain an initial setting.

3. Dicalcium silicate (C2S)

As opposed to tricalcium silicate, which helps early strength gain, dicalcium silicate in cement helps the strength gain after one week.

4. Ferrite (C4AF)

Ferrite is a fluxing agent. It reduces the melting temperature of the raw materials in the kiln from 3,000°F to 2,600°F. Though it hydrates rapidly, it does not contribute much to the strength of the cement.

5. Magnesia (MgO)

The manufacturing process of Portland cement uses magnesia as a raw material in dry process plants. An excess amount of magnesia may make the cement unsound and expansive, but a little amount of it can add strength to the cement. Production of MgO-based cement also causes less CO₂ emission. All cement is limited to a content of 6% MgO.

6. Sulphur trioxide

Sulfur trioxide in excess amount can make cement unsound.

7. Iron oxide/ Ferric oxide

Aside from adding strength and hardness, iron oxide or ferric oxide is mainly responsible for the color of the cement.

8. Alkalis

The amounts of potassium oxide (K_2O) and sodium oxide (Na_2O) determine the alkali content of the cement. Cement containing large amounts of alkali can cause some difficulty in regulating the setting time of cement. Low alkali cement, when used with calcium chloride in concrete, can cause discoloration. In slag-lime cement, ground granulated blast furnace slag is not hydraulic on its own but is "activated" by addition of alkalis. There is an optional limit in total alkali content of 0.60%, calculated by the equation $Na_2O + 0.658 K_2O$.

9. Free lime

Free lime, which is sometimes present in cement, may cause expansion.

10. Silica fumes

Silica fume is added to cement concrete in order to improve a variety of properties, especially compressive strength, abrasion resistance and bond strength. Though setting time is prolonged by the addition of silica fume, it can grant exceptionally high strength. Hence, Portland cement containing 5-20% silica fume is usually produced for Portland cement projects that require high strength.

11.11.

Cement containing high alumina has the ability to withstand frigid temperatures since alumina is chemical-resistant. It also quickens the setting but weakens the cement.

Aggregates:

What is an Aggregate?

Aggregates are the important constituents of the concrete which give body to the concrete and also reduce shrinkage. Aggregates occupy 70 to 80 % of total volume of concrete. So, we can say that one should know definitely about the aggregates in depth to study more about concrete.

Classification of Aggregates as per Size and Shape

Aggregates are classified based on so many considerations, but here we are going to discuss about their shape and size classifications in detail.

Classification of Aggregates Based on Shape

We know that aggregate is derived from naturally occurring rocks by blasting or crushing etc., so, it is difficult to attain required shape of aggregate. But, the shape of aggregate will affect the workability of concrete. So, we should take care about the shape of aggregate. This care is not only applicable to parent rock but also to the crushing machine used.

Aggregates are classified according to shape into the following types

- Rounded aggregates
- Irregular or partly rounded aggregates
- Angular aggregates
- Flaky aggregates
- Elongated aggregates
- Flaky and elongated aggregates

Rounded Aggregate

The rounded aggregates are completely shaped by attrition and available in the form of seashore gravel. Rounded aggregates result the minimum percentage of voids (32 – 33%) hence gives more workability. They require lesser amount of water-cement ratio. They are not considered for high strength concrete because of poor interlocking behavior and weak bond strength.



FIG-1

Irregular Aggregates

The irregular or partly rounded aggregates are partly shaped by attrition and these are available in the form of pit sands and gravel. Irregular aggregates may result 35- 37% of voids. These will give lesser workability when compared to rounded aggregates. The bond strength is slightly higher than rounded aggregates but not as required for high strength concrete.



FIG-2

Angular Aggregates

The angular aggregates consist well defined edges formed at the intersection of roughly planar surfaces and these are obtained by crushing the rocks.

Angular aggregates result maximum percentage of voids (38-45%) hence gives less workability. They give 10-20% more compressive strength due to development of stronger aggregate-mortar bond. So, these are useful in high strength concrete manufacturing.



FIG-3

Flaky Aggregates

When the aggregate thickness is small when compared with width and length of that aggregate it is said to be flaky aggregate. Or in the other, when the least dimension of aggregate is less than the 60% of its mean dimension then it is said to be flaky aggregate.



FIG-4

Elongated Aggregates

When the length of aggregate is larger than the other two dimensions then it is called elongated aggregate or the length of aggregate is greater than 180% of its mean dimension.



FIG-5

Flaky and Elongated Aggregates

When the aggregate length is larger than its width and width is larger than its thickness then it is said to be flaky and elongated aggregates. The above 3 types of aggregates are not suitable for concrete mixing. These are generally obtained from the poorly crushed rocks. FIG-6



Classification of Aggregates Based on Size

Aggregates are available in nature in different sizes. The size of aggregate used may be related to the mix proportions, type of work etc. the size distribution of aggregates is called grading of aggregates.

Following are the classification of aggregates based on size:

Aggregates are classified into 2 types according to size

- Fine aggregate
- Coarse aggregate

Fine Aggregate

When the aggregate is sieved through 4.75mm sieve, the aggregate passed through it called as fine aggregate. Natural sand is generally used as fine aggregate, silt and clay are also come under this category. The soft deposit consisting of sand, silt and clay is termed as loam. The purpose of the fine aggregate is to fill the voids in the coarse aggregate and to act as a workability agent.

Fine aggregate	Size variation
Coarse Sand	2.0mm – 0.5mm
Medium sand	0.5mm – 0.25mm
Fine sand	0.25mm – 0.06mm
Silt	0.06mm – 0.002mm
Clay	<0.002

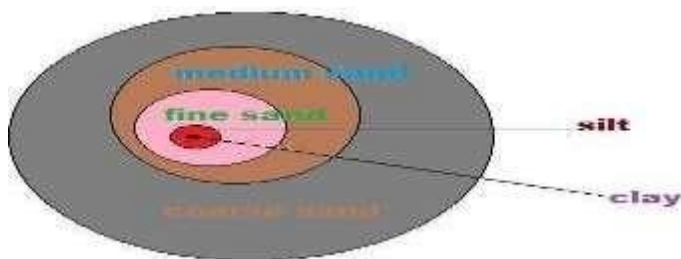

FIG-7

Coarse Aggregate

When the aggregate is sieved through 4.75mm sieve, the aggregate retained is called coarse aggregate. Gravel, cobble and boulders come under this category. The maximum size aggregate used may be dependent upon some conditions. In general, 40mm size aggregate used for normal strengths and 20mm size is used for high strength concrete. the size range of various coarse aggregates given below.

Coarse aggregate	Size
Fine gravel	4mm – 8mm
Medium gravel	8mm – 16mm
Coarse gravel	16mm – 64mm
Cobbles	64mm – 256mm
Boulders	>256mm

Bulking of Sand

The increase in moisture of sand increases the volume of sand. The reason is that moisture causes film of water around sand particles which results in the increase of volume of sand. For a moisture content percentage of 5 to 8 there will be an increase in volume up to 20 to 40 percent depending upon sand. If the sand is finer there will be more increase in volume. This is known as bulking of sand.

Graphical representation of bulking of sand is shown below.

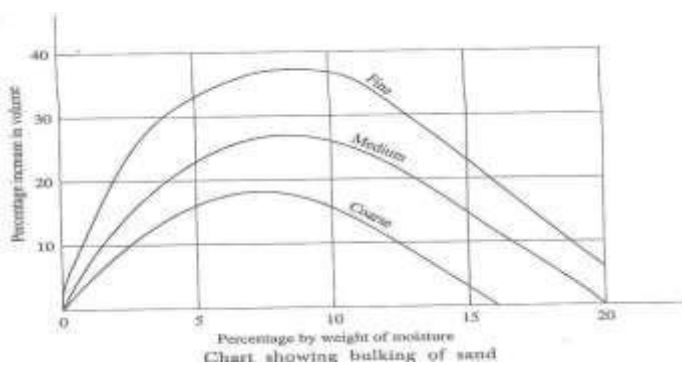

FIG-8

When the moisture content of sand is increased by adding more water, the sand particles pack near each other and the amount of **bulking of sand** is decreased. Thus, it helps in determining the actual volume of sand, the dry sand and the sand completely filled with water will have the exact volume.

The volumetric proportioning of sand is greatly affected by bulking of sand to a greater extent. The affected volume will be great for fine sand and will be less for coarse sand. If proper allowance is not made for the bulking of sand, the cost of concrete and mortar increases and it results into under-sanded mixes which are harsh and difficult for working and placing.

SPECIFIC GRAVITY AND WATER ABSORPTION TEST

AIM:

i) To measure the strength or quality of the material ii) To determine the water absorption of aggregates

-

APPARATUS:

The apparatus consists of the following

- (a) A balance of capacity about 3kg, to weigh accurate 0.5g, and of such a type and shape as to permit weighing of the sample container when suspended in water.
- (b) A thermostatically controlled oven to maintain temperature at 100-110° C.
- (c) A wire basket of not more than 6.3 mm mesh or a perforated container of convenient size with thin wire hangers for suspending it from the balance. (d) A container for filling water and suspending the basket
- (e) An air tight container of capacity similar to that of the basket
- (f) A shallow tray and two absorbent clothes, each not less than 75x45cm.

-

THEORY:

The specific gravity of an aggregate is considered to be a measure of strength or quality of the material. Stones having low specific gravity are generally weaker than those with higher specific gravity values.

-

PROCEDURE:

- (i) About 2 kg of aggregate sample is washed thoroughly to remove fines, drained and placed in wire basket and immersed in distilled water at a temperature between 22- 32° C and a cover of at least 5cm of water above the top of basket.
- (ii) Immediately after immersion the entrapped air is removed from the sample by lifting the basket containing it 25 mm above the base of the tank and allowing it to drop at the rate of about one drop per second. The basket and aggregate should remain completely immersed in water for a period of 24 hour afterwards.
- (iii) The basket and the sample are weighed while suspended in water at a temperature of 22° – 32°C. The weight while suspended in water is noted =W1g.
- (iv) The basket and aggregates are removed from water and allowed to drain for a few minutes, after which the aggregates are transferred to the dry absorbent clothes. The empty basket is then returned to the tank of water jolted 25 times and weighed in water=W2g. .

(v) The aggregates placed on the absorbent clothes are surface dried till no further moisture could be removed by this cloth. Then the aggregates are transferred to the second dry cloth spread in single layer and allowed to dry for at least 10 minutes until the aggregates are completely surface dry. The surface dried aggregate is then weighed =W3 g

(vi) The aggregate is placed in a shallow tray and kept in an oven maintained at a temperature of 110° C for 24 hrs. It is then removed from the oven, cooled in an air tight container and weighted=W4 g.

Specific gravity = (dry weight of the aggregate /Weight of equal volume of water)

(1) Apparent specific gravity = (dry weight of the aggregate/Weight of equal volume of water excluding air voids in aggregate)

OBSERVATIONS

Weight of saturated aggregate suspended in water with basket = W1 g Weight of basket suspended in water = W2 g

Weight of saturated aggregate in water = W1 – W2 g Weight of saturated surface dry aggregate in air = W3 g

Weight of water equal to the volume of the aggregate = W3–(W1–W2)g Weight of oven dry aggregate = W4 g

(1) Specific gravity = $W3 / (W3 - (W1 - W2))$

(2) Apparent specific gravity = $W4 / (W4 - (W1 - W2))$ (3) Water

Absorption = $((W3 - W4) / W4) \times 100$

RESULT:

(1) Specific gravity =

(2) Apparent specific gravity = (3)

Water Absorption =

RECOMMENDED VALUE:

The size of the aggregate and whether it has been artificially heated should be indicated. ISI specifies three methods of testing for the determination of the specific gravity of aggregates, according to the size of the aggregates. The three size ranges used are aggregates larger than 10 mm, 40 mm and smaller than 10 mm. The specific gravity of aggregates normally used in road construction ranges from about 2.5 to 3.0 with an average of about 2.68. Though high specific gravity is considered as an indication of high strength, it is not possible to judge the suitability of a sample road aggregate without finding the mechanical properties such as aggregate crushing, impact and abrasion values. Water

absorption shall not be more than 0.6 per unit by weight.

Unit 3

Water Cement Ratio

Hydration of Cement

Introduction

Portland cement is a hydraulic cement; hence it derives its strength from chemical reactions between the cement and water. The process is known as hydration.

Cement consists of the following major compounds (see [composition of cement](#)):

- Tricalcium silicate, C_3S
- Dicalcium silicate, C_2S
- Tricalcium aluminate, C_3A
- Tetra calcium aluminoferrite, C_4AF
- Gypsum, CSH_2

Water–cement ratio

The **water–cement ratio** is the ratio of the weight of water to the weight of [cement](#) used in a [concrete](#) mix. A lower ratio leads to higher strength and durability, but may make the mix difficult to work with and form. Workability can be resolved with the use of [plasticizers](#) or [super-plasticizers](#).

Often, the ratio refers to the ratio of water to cement plus [pozzolan](#) ratio, $w/(c+p)$. The pozzolan is typically a [fly ash](#), or [blast furnace slag](#). It can include a number of other materials, such as silica fume, rice husk ash or natural pozzolans. Pozzolans can be added to strengthen concrete.

Duff Abrams' law

The notion of water–cement ratio was first developed by [Duff A. Abrams](#) and published in 1918.

Concrete hardens as a result of the chemical reaction between cement and water (known

as [hydration](#), this produces heat and is called the heat of hydration). For every pound (or kilogram or any unit of weight) of cement, about 0.35 pounds (or 0.35 kg or corresponding unit) of water is needed to fully complete hydration reactions.

However, a mix with a ratio of 0.35 may not mix thoroughly, and may not flow well enough to be placed. More water is therefore used than is technically necessary to react with cement. Water–cement ratios of 0.45 to 0.60 are more typically used. For higher-strength concrete, lower ratios are used, along with a plasticizer to increase flowability.

Too much water will result in [segregation of the sand and aggregate components from the cement paste](#)

Effect of Water Cement Ratio on Strength of Concrete:

The water-cement ratio is one of the most important aspect when it comes to maintaining the strength of Concrete. The ratio depends on the grade of concrete and the structure size. We generally prefer a W/C ratio of 0.4 to 0.6, but it can be decreased in case of high-grade concrete, we reduce the amount of water and use plasticizers instead.

W/C ratio affects the workability of concrete and thus should be taken into careful consideration. Also, if the ratio exceeds the normal value, segregation of concrete occurs and the coarse aggregate settles at the bottom, thus affecting the strength of concrete greatly.

Limitation of Water Cement Law:

1. The internal moisture condition of hydration of cement continues till the concrete gain full strength.
2. The concrete specimen is cured under standard temperatures.
3. The concrete specimens should of same size.
4. The concrete specimens should of same age.

Unit- 4

Workability

Workability is defined as the amount of energy required to overcome internal friction and cause complete compaction.

Workability is completely depending upon the properties of various ingredients of concrete.

Factors Affecting Workability

-Cement content of concrete

Water content of concrete Mix

proportions of concrete Size of

aggregates

Shape of aggregates

Grading of aggregates

Surface texture of aggregates Use

of admixtures in concrete

Use of supplementary cementitious materials

Following are the general factors affecting concrete workability:

1. Cement Content of Concrete

Cement content affects the workability of concrete in good measure. More the quantity of cement, the more will be the paste available to coat the surface of aggregates and fill the voids between them. This will help to reduce the friction between aggregates and smooth movement of aggregates during mixing, transporting, placing and compacting of concrete.

Also, for a given water-cement ratio, the increase in the cement content will also increase the water content per unit volume of concrete increasing the workability of concrete. Thus, increase in cement content of concrete also increases the workability of concrete.

2. Type and Composition of Cement

There are also affect of type of cement or characteristics of cement on the workability of concrete. The cement with increase in fineness will require more water for same workability than the comparatively less fine cement. The water demand increased for cement with high Al₂O₃ or C₂S contents.

3. Water/Cement Ratio or Water Content of Concrete

Water/cement ratio is one of the most important factors which influence the concrete workability. Generally, a water cement ratio of 0.45 to 0.6 is used for good workable concrete without the use of any admixture. Higher the water/cement ratio, higher will be the water content per volume of concrete and concrete will be more workable.

Higher water/cement ratio is generally used for manual concrete mixing to make the mixing process easier. For machine mixing, the water/cement ratio can be reduced. These generalized method of using water content per volume of concrete is used only for nominal mixes.

For designed mix concrete, the strength and durability of concrete is of utmost importance and hence water cement ratio is mentioned with the design. Generally designed concrete uses low water/cement ratio so that desired strength and durability of concrete can be achieved.

4. Mix Proportions of Concrete

Mix proportion of concrete tells us the ratio of fine aggregates and coarse aggregates w.r.t. cement quantity. This can also be called as the aggregate cement ratio of concrete. The more cement is used, concrete becomes richer and aggregates will have proper lubrications for easy mobility or flow of aggregates.

The low quantity of cement w.r.t. aggregates will make the less paste available for aggregates and mobility of aggregates is restrained.

5. Size of Aggregates

Surface area of aggregates depends on the size of aggregates. For a unit volume of aggregates with large size, the surface area is less compared to same volume of aggregates with small sizes.

When the surface area increases, the requirement of cement quantity also increases to cover up the entire surface of aggregates with paste. This will make more use of water to lubricate each aggregate.

Hence, lower sizes of aggregates with same water content are less workable than the large size aggregates.

6. Shape of Aggregates

The shape of aggregates affects the workability of concrete. It is easy to understand that rounded aggregates will be easy to mix than elongated, angular and flaky aggregates due to less frictional resistance.

Other than that, the round aggregates also have less surface area compared to elongated or irregular shaped aggregates. This will make less requirement of water for same workability of concrete. This is why river sands are commonly preferred for concrete as they are rounded in shape.

7. Grading of Aggregates

Grading of aggregates have the maximum effect on the workability of concrete. A well graded aggregates have all sizes in required percentages. This helps in reducing the voids in a given volume of aggregates.

The less volume of voids makes the cement paste available for aggregate surfaces to provide better lubrication to the aggregates.

With less volume of voids, the aggregate particles slide past each other and less compacting effort is required for proper consolidation of aggregates. Thus, low water cement ratio is sufficient for properly graded aggregates.

8. Surface Texture of Aggregates

Surface texture such as rough surface and smooth surface of aggregates affects the workability of concrete in the same way as the shape of aggregates.

With rough texture of aggregates, the surface area is more than the aggregates of same volume with smooth texture. Thus, concrete with smooth surfaces are more workable than with rough textured aggregates.

9. Use of Admixtures in Concrete

There are many types of admixtures used in concrete for enhancing its properties. There are some workability enhancer admixtures such as plasticizers and superplasticizers which increases the workability of concrete even with low water/cement ratio.

They are also called as water reducing concrete admixtures. They reduce the quantity of water required for same value of slump.

Air entraining concrete admixtures are used in concrete to increase its workability. This admixture reduces the friction between aggregates by the use of small air bubbles which acts as the ball bearings between the aggregate particles.

Measurement of Workability:

Slump Test.

Concrete slump test is to determine the workability or consistency of concrete mix prepared at the laboratory or the construction site during the progress of the work. Concrete slump test is carried out from batch to batch to check the uniform quality of concrete during construction.

The slump test is the simplest workability test for concrete, involves low cost and provides immediate results. Due to this fact, it has been widely used for workability tests since 1922. The slump is carried out as per procedures mentioned in **IS 456: 2000**

Generally **concrete slump value** is used to find the workability, which indicates water-cement ratio, but there are various factors including properties of materials, mixing methods, dosage, admixtures etc. also affect the concrete slump value.

Factors which influence the concrete slump test:

-Material properties like chemistry, fineness, particle size distribution, moisture content and temperature of cementitious materials.

- Size, texture, combined grading, cleanliness and moisture content of the aggregates,

-Chemical admixtures dosage, type, combination, interaction, sequence of addition and its effectiveness,

-Air content of concrete,

-Concrete batching, mixing and transporting methods and equipment,

-Temperature of the concrete,

- Sampling of concrete, slump-testing technique and the condition of test equipment,
- The amount of free water in the concrete, and
- Time since mixing of concrete at the time of testing.

Equipment's Required for Concrete Slump Test:

Mould for slump test, non-porous base plate, measuring scale, tamping rod. The mould for the test is in the form of the frustum of a cone having height 30 cm, bottom diameter 20 cm and top diameter 10 cm. The tamping rod is of steel 16 mm diameter and 60cm long and rounded at one end.

Sampling of Materials for Slump Test:

A concrete mix (M15 or other) by weight with suitable water/ cement ratio is prepared in the laboratory similar to that explained in 5.9 and required for casting 6 cubes after conducting Slump test.

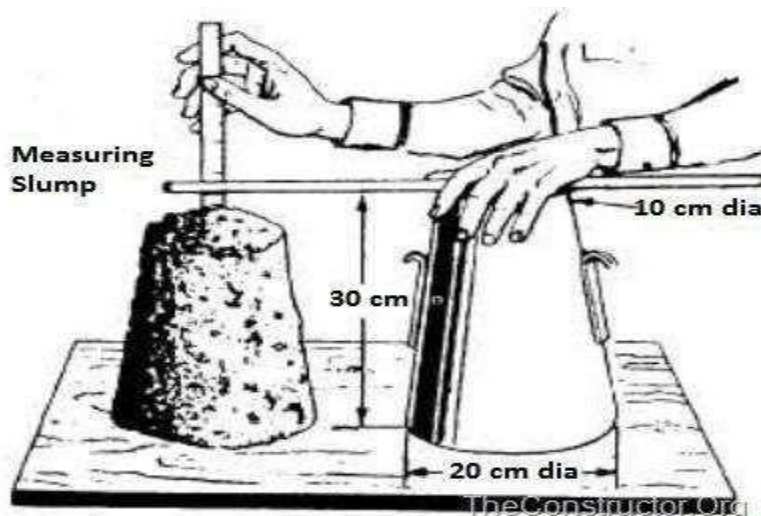

FIG-1

1. Compaction Factor Test

Compaction factor test is the workability test for concrete conducted in laboratory. The compaction factor is the ratio of weights of partially compacted to fully compacted concrete. It was developed by Road Research Laboratory in United Kingdom and is used to determine the workability of concrete.

The compaction factor test is used for concrete which have low workability for which slump test is not

suitable.

Apparatus

Compaction factor apparatus consists of trowels, hand scoop (15.2 cm long), a rod of steel or other suitable material (1.6 cm diameter, 61 cm long rounded at one end) and a balance.

Sampling

Concrete mix is prepared as per mix design in the laboratory.

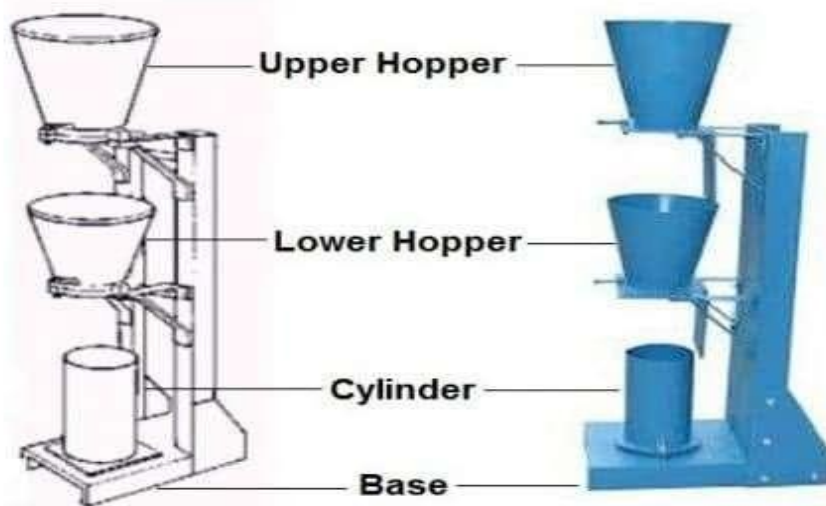

Compaction Factor Test on Concrete

FIG-2

Procedure of Compaction Factor Test on Concrete

-Place the concrete sample gently in the upper hopper to its brim using the hand scoop and level it.

-Cover the cylinder.

-Open the trapdoor at the bottom of the upper hopper so that concrete fall into the lower hopper. Push the concrete sticking on its sides gently with the rod.

-Open the trapdoor of the lower hopper and allow the concrete to fall into the cylinder below.

-Cut off the excess of concrete above the top level of cylinder using trowels and level it.

-Clean the outside of the cylinder.

-Weight the cylinder with concrete to the nearest 10 g. This weight is known as the weight of partially compacted concrete (W_1).

-Empty the cylinder and then refill it with the same concrete mix in layers approximately 5 cm deep, each layer being heavily rammed to obtain full compaction.

-Level the top surface.

-Weigh the cylinder with fully compacted. This weight is known as the weight of fully compacted concrete (W_2).

-Find the weight of empty cylinder (W).

2. VEE-BEE CONSISTOMETER TEST



FIG-3

SUITABILITY

This method is suitable for dry concrete having very low workability

PROCEDURE

The test is performed as given described below

1. Mix the dry ingredients of the concrete thoroughly till a uniform colour is obtained and then add the required quantity of water.

(Prepared By: Mr. Saurabh, Assistant Professor, civil)

2. Pour the concrete into the slump cone with the help of the funnel fitted to the stand.
3. Remove the slump mould and rotate the stand so that transparent disc touches the top of the concrete.
4. Start the vibrator on which cylindrical container is placed.
5. Due to vibrating action, the concrete starts remoulding and occupying the cylindrical container. Continue vibrating the cylinder till concrete surface becomes horizontal.
6. The time required for complete remoulding in seconds is the required measure of the workability and it is expressed as number of Vee-bee seconds.

COMPARISON OF WORKABILITY MEASUREMENTS BY VARIOUS METHODS

Workability Description	Slump in mm	Vee-bee Time in Seconds	Compacting Factor
Extremely dry	–	32 – 18	
Very stiff	–	18 – 10	0.70
Stiff	0 – 25	10 – 5	0.75
Stiff plastic	25 – 50	5 – 3	0.85
Plastic	75 – 100	3 – 0	0.90
Flowing	150 – 175	–	0.95

(Prepared By: Mr. Saurabh, Assistant Professor, civil)

CHAPTER-5

CONCRETE MIX DESIGN

INTRODUCTION

The common method of expressing the proportions of ingredients of a concrete mix is in the terms of parts or ratios of cement, fine and coarse aggregates. For e.g., a concrete mix of proportions 1:2:4 means that cement, fine and coarse aggregate are in the ratio 1:2:4 or the mix contains one part of cement, two parts of fine aggregate and four parts of coarse aggregate. The proportions are either by volume or by mass. The water-cement ratio is usually expressed in mass.

Concrete mix design may be defined as the art of selecting suitable ingredients of concrete and determining their relative proportions with the object of producing concrete of certain minimum strength & durability as economically as possible.

Objectives of Mix Design

- To achieve the designed/ desired workability in the plastic stage
- To achieve the desired minimum strength in the hardened stage
- To achieve the desired durability in the given environment conditions
- To produce concrete as economically as possible.

Factors to be considered for mix design

- The grade designation giving the characteristic strength requirement of concrete.
- The type of cement influences the rate of development of compressive strength of concrete.
- Maximum nominal size of aggregates to be used in concrete may be as large as possible within the limits prescribed by IS 456:2000.
- The cement content is to be limited from shrinkage, cracking and creep.
- The workability of concrete for satisfactory placing and compaction is related to the size and shape of section, quantity and spacing of reinforcement and technique used for transportation, placing and compaction.

Basic Considerations

- Cost
- Specification
- Workability
- Strength and Durability

Cost

The cost of concrete is made up of

- Material Cost

(Prepared By: Mr. Saurabh, Assistant Professor, civil)

- Equipment Cost
- Labour Cost

The variation in the cost of materials arises from the fact that cement is several times costlier than aggregates. So, it is natural in mix design to aim at as lean a mix as possible. Therefore, all possible steps should be taken to reduce the cement content of a concrete mixtures without sacrificing the desirable properties of concrete such as strength and durability.

Specifications

- Minimum Compressive Strength required
- Minimum water/ cement ratio
- Maximum cement content to avoid shrinkage cracks
- Maximum aggregate / cement ratio
- Maximum density of concrete in case of gravity dams

Workability

The consistency of concrete should no more than that necessary for placing, compacting and finishing. For concrete mixes required high consistency at the time of placing, the use of water-reducing and set-retarding admixtures should be used rather than the addition of more water.

Wherever possible, the cohesiveness and fishability of concrete should be improved by increasing sand/ aggregate ratio than by increasing the proportion of the fine particles in the sand.

Strength and durability

Strength and durability require lower w/c ratio. It is usually achieved not by increasing the cement content, but by lowering the water at given cement content. Water demand can be lowered by throughout control of the aggregate grading and by using water reducing admixtures.

Grade of Concrete		
Group	Grade designation	Characteristics compressive strength of 150 mm cube at 28 days, N/mm ²
Ordinary Concrete	M10	10
	M15	15
	M20	20
Standard Concrete	M25	25
	M30	30
	M35	35
	M40	40
	M45	45
	M50	50
	M55	55
High Strength Concrete	M60	60
	M65	65
	M70	70
	M75	75
	M80	80

TABLE 5.1

(Prepared By: Mr. Saurabh, Assistant Professor, civil)

TYPES OF CONCRETE MIXES

A. NOMINAL MIX

The wide use of concrete as construction materials has led to the use of mixes of fixed proportion, which ensures adequate strength. These mixes are called nominal mixes.

They offer simplicity and Under normal circumstances, has margin of strength above that specified. Nominal mix concrete may be used for concrete of grades M5, M 7.5, M10, M15 and M20.

Mixes of fixed proportions, IS:456-2000 permits nominal mixes for concretes of strength M20 or lower

Grade	Proportions C: FA: CA
M5	1: 5:10
M 7.5	1:4:8
M 10	1:3:6
M 15	1:2:4
M 20	1:1.5:3

TABLE 5.2- Proportions of Ingredients in Nominal Mixes

B. DESIGN MIX

Designed on the basis of requirements of the concrete in fresh and hardened states.

Factors Influencing Choice of Mix Design

According to IS 456:2000 and IS 1343:1980 the important influencing the design of concrete mix are

- Grade of Concrete
- Type of Cement
- Maximum nominal Size of Aggregate
- Grading of Combined aggregate
- Maximum Water/ Cement Ratio
- Workability
- Durability
- Quality Control.

Grade of Concrete

The grade of concrete gives characteristic compressive strength of concrete. It is one of the important factors influencing the mix design. The grade M 20 denotes characteristic compressive

(Prepared By: Mr. Saurabh, Assistant Professor, civil)

strength of 20 N/mm². Depending upon the degree of control available at site, the concrete mix is to be designed for a target mean compressive strength applying suitable standard deviation.

DESIGNATION	MIX PROPORTION	CHARACTERISTIC COMPRESSIVE STRENGTH IN N/MM ²	GROUP AS PER IS 456-2000
M 5	1:5:10	5	LEAN MIX
M 7.5	1:4:8	7.5	
M 10	1:3:6	10	ORDINARY CONCRETE
M 15	1:2:4	15	
M 20	1:11/2:3	20	
M 25	1:1:2	25	STANDERD CONCRETE
M 30	DESIGNED	30	
M 35		35	
M 40		40	
M 45		45	
M 50		50	
M 55		55	
M 60		60	

TABLE-5.3

Type of Cement

The rate of development of strength of concrete is influenced by the type of cement. The higher the strength of cement used in concrete, lesser will be the cement content. The use of 43 grade and 53 grades of cement, gives saving in cement consumption as much as 15 % and 25 % respectively, as compared to 33 grades of cement. For concrete of grade M25 it is advisable to use 43 and 53 grades of cement.

Maximum nominal Size of Aggregate

The maximum size of C.A is determined by sieve analysis. It is designated by the sieve size higher than larger size on which 15 % or more of the aggregate is retained. The maximum nominal size of C.A. should not be more than one-fourth of minimum thickness of the member.

For heavily reinforced concrete members as in the case of ribs of main beams, the nominal maximum size of the aggregate should usually be restricted to sum less than the minimum clear distance between the main bars or 5 mm less the minimum cover to the reinforcement, whichever is smaller.

Grading of Combined aggregate

The relative proportions of the fine and coarse aggregate in a concrete mix is one of the important factors affecting the strength of concrete. For dense concrete, it is essential that the fine and coarse aggregate be well graded. In the case when the aggregate available from natural sources do not confirm to the specified grading, the proportioning of two or more aggregate become essential.

(Prepared By: Mr. Saurabh, Assistant Professor, civil)

Maximum Water/ Cement Ratio

Abram's water/Cement ratio states that for any given condition of test, the strength of a workability concrete mix is dependent only on water/cement ratio. The lower the water/Cement ratio, the greater is the compressive strength.

Workability

Workability of fresh concrete determines the ease with which a concrete mixture can be mixed, transported, placed, compacted and finished without harmful segregation and bleeding.

Durability

Durability requires low water/Cement ratio. It is usually achieved not by increasing the cement content, but by lowering the water demand at a given cement content. Water demand can be lowered by through control of the aggregate grading and by using water reducing admixtures.

Procedure for Concrete Mix Design – IS456:2000

- Determine the mean target strength f_t from the specified characteristic compressive strength at 28-day f_{ck} and the level of quality control.
- $f_t = f_{ck} + 1.65 S$
- Where, S is the standard deviation obtained from the Table of approximate contents given after the design mix.
- Obtain the water cement ratio for the desired mean target using the empirical relationship between compressive strength and water cement ratio so chosen is checked against the limiting water cement ratio. The water cement ratio so chosen is checked against the limiting water cement ratio for the requirements of durability given in table and adopts the lower of the two values.
- Estimate the amount of entrapped air for maximum nominal size of the aggregate from the table.
- Select the water content, for the required workability and maximum size of aggregates (for aggregates in saturated surface dry condition) from table.
- Determine the percentage of fine aggregate in total aggregate by absolute volume from table for the concrete using crushed coarse aggregate.
Smartworld.com Smartworld.asiajntuworldupdates.org Specworld.in
- Adjust the values of water content and percentage of sand as provided in the table for any difference in workability, water cement ratio, grading of fine aggregate and for rounded aggregate the values are given in table.
- Calculate the cement content from the water-cement ratio and the final water content as arrived after adjustment. Check the cement against the minimum cement content from the requirements of the durability, and greater of the two values is adopted.

(Prepared By: Mr. Saurabh, Assistant Professor, civil)

- From the quantities of water and cement per unit volume of concrete and the percentage of sand already determined in steps 6 and 7 above, calculate the content of coarse and fine aggregates per unit volume of concrete from the following relations:

$$V = \left[W + \frac{C}{S_c} + \frac{1}{p} \frac{f_a}{S_{fa}} \right] \times \frac{1}{1000}$$

$$V = \left[W + \frac{C}{S_c} + \frac{1}{1-p} \frac{C_a}{S_{ca}} \right] \times \frac{1}{1000}$$

- Where, V = absolute volume of concrete = gross volume (1m³) minus the volume of entrapped air
 S_c = specific gravity of cement
W = Mass of water per cubic metre of concrete, kg
C = mass of cement per cubic metre of concrete, kg
p = ratio of fine aggregate to total aggregate by absolute volume
 f_a , C_a = total masses of fine and coarse aggregates, per cubic metre of concrete, respectively, kg, and S_{fa} , S_{ca} = specific gravities of saturated surface dry fine and coarse aggregates, respectively
- Determine the concrete mix proportions for the first trial mix.
- Prepare the concrete using the calculated proportions and cast three cubes of 150 mm size and test them wet after 28-days moist curing and check for the strength.
- Prepare trial mixes with suitable adjustments till the final mix proportions are arrived at.

Difference between nominal and controlled concrete

- NOMINAL MIX**
It is used for relatively unimportant and simpler concrete works. In this type of mix, all the ingredients are prescribed and their proportions are specified.
Therefore, there is no scope for any deviation by the designer. Nominal mix concrete may be used for concrete of M-20 or lower.
- DESIGN MIX**
It is a performance-based mix where choice of ingredients and proportioning are left to the designer to be decided. The user has to specify only the requirements of concrete in fresh as well as hardened state. The requirements in fresh concrete are workability and finishing characteristics, whereas in hardened concrete these are mainly the compressive strength and durability.

Nominal Mix	• DESIGN MIX (CONTROLLED CONCRETE)
When the concrete is produced by taking standard arbitrary proportions of concrete	It can be defined as the process of selecting suitable ingredients of concrete and

(Prepared By: Mr. Saurabh, Assistant Professor, civil)

ingredients, it is known as nominal mix concrete	determining their relative proportions with the object of producing concrete of certain minimum strength and durability as economically as possible
Nominal mix is a mix considering all ratio in volume where Strength and cost of concrete and strength of concrete varies	Design mix is a mix considering all ratio of mix is by weight where strength of concrete is constant cost of concrete can be reduced
It is Prescriptive type concrete.	It is Performance based concrete.
It is used in ordinary concrete involving concrete grade not higher than M20	It is adopted for higher grade concrete
There is no quality control	It has Quality control
Water cement ratio is based on durability criteria, experience & practical trials	Water cement ratio based on concrete grade & 28 days compressive strength of concrete & durability of concrete.
Water content can be modified by slump value (field-based test)	Water content could be modified taking in to account the compaction factor value (laboratory-based test)
No entrapped air content is considered	Entrapped air content considered according nominal maximum size aggregates
Trial mixes concept is mentioned	Not much consideration for trial mixes

(Prepared By: Mr. Saurabh, Assistant Professor, civil)

CH-6

Introduction to Admixtures

Admixtures are chemicals, added to concrete, mortar or grout at the time of mixing, to modify the properties, either in the wet state immediately after mixing or after the mix has hardened. They can be a single chemical or a blend of several chemicals and may be supplied as powders but most are **aqueous solutions** because in this form, they are easier to accurately dispense into, and then disperse through the concrete.

- Admixtures are ingredients other than basic ingredients cement, water and aggregates that are added to concrete batch immediately before or during mixing to modify one or more of the specific properties of concrete in fresh and hardened state.
- Added in small quantity either in powder or liquid form
- Combination is used when more than one property to be altered.

1 Admixtures can be divided into three categories: -

- Active materials are those which react chemically with a component within the Cementations materials.
- Surface active admixtures (surfactants). These are generally split into two components (one positively charged and the other negatively charged) and react with the air - water - solid material interface within the mortar thereby resulting in orientation and adsorption.
- Passive or inert admixtures. These do not change their form but have a physical effect such as light absorption and reflection as in the case of pigments.

2 Function

- Increase slump and workability;

(Prepared By: Mr. Saurabh, Assistant Professor, civil)

- Retard or accelerate initial setting;
- Reduce or prevent shrinkage;
- Modify the rate or capacity for bleeding;
- Reduce segregation;
- Decrease weight of concrete
- Improve durability
- Decrease the rate of heat of hydration
- Reduce permeability
- To make porous concrete
- To make coloring concrete
- To protect chemical attack
- Increase bond of concrete to steel reinforcement
- Increase strength (compressive, tensile, or flexural)
- Increase bond between existing and new concrete

3 Types of admixture

1. Accelerating admixtures
2. retarding admixtures
3. Water-reducing admixtures
4. Air-entrainment admixtures
5. Super plasticizers admixtures
6. Pozzolana admixtures
7. Grouting admixtures
8. Waterproofing admixtures
9. Air-detraining admixtures
10. Bonding admixtures
11. Corrosion inhibiting admixtures
12. Gas forming admixtures
13. Colouring admixtures
14. Alkali-aggregate expansion inhibiting admixtures
15. Fungicidal, germicidal, insecticidal admixtures

4.1 . Accelerators: -

Main objective of using accelerators in concrete is to increase speed of setting and hardening.

Advantages of using Accelerators: -

- To remove formwork quickly.
- To reduce the curing time
- To use structure earlier.
- To finish the surface fast.
- To increase the speed of construction.

(Prepared By: Mr. Saurabh, Assistant Professor, civil)

- For quick repairing work.

Main Accelerators: -

- Calcium Chloride (CaCl₂)
- Soluble Carbonates
- Silicates

CaCl₂ is a most using accelerator in construction. If 2% CaCl₂ by weight of cement is added in concrete, then it decreases the setting time from 3 to 1 hour and final setting time from 6 to 2 hour. We can get a two days strength in 1 day at 21 ° C temperature. If the proportion of CaCl₂ is more than 3% then flash set of concrete take place and drying shrinkage and creep will increase.

Retarders: -

To decrease the speed of Hydration and setting, Retarders are used in concrete. Retarders make concrete plastic and workable for long time.

Objectives of using Retarders: -

- To decrease the setting time.
- To increase strength by decreasing W/C Ratio.
- To do concreting in hot area.
- For grouting of oil wells.

Main Retarders: -

- Calcium Sulphate (Gypsum)
- Starches
- Sugars
- Cellulose Products
- Acids or Salts

Gypsum is most commonly used retarder. Generally, 2 to 3% gypsum is added. We can also use gypsum as a plaster of parries. By use more of gypsum expansion of concrete will occur and setting of concrete will be very slow.

Plasticizers: -

Workability is a most important property of concrete. Workability of concrete will change according to situation of construction. For deep beam, light partition wall, beam-column junction, concrete pumping,

(Prepared By: Mr. Saurabh, Assistant Professor, civil)

tremie concreting high workable concrete is used. Many time plasticizers also known as “Water Reducing Admixture”. Plasticizer increases the workability without adding much water. It decreases the W/C Ratio which increases the strength.

Main plasticizers used in Construction: -

- Calcium lignosulphonates
- Sodium lignosulphonates
- Ammonium lignosulphonates

Quantity of this type of plasticizers is up to 0.1 to 0.4%.

By Using this admixture, we can reduce the use of water up to 5 to 15% without changing workability. **Main function of plasticizers is to improve the workability.**

Uses of plasticizers The plasticizers are used:

- To achieve a higher strength by decreasing the water cement ratio at the same workability as an admixture free mix.
- To achieve the same workability by decreasing the cement content to reduce the heat of hydration in mass concrete.
- To increase the workability to ease placing in accessible locations.
- Water reduction more than 5% but less than 12%
- The commonly used admixtures are Ligno-sulphonates and hydrocarbolic acid salts.
- Plasticizers are usually based on lignosulphonate, which is a natural polymer, derived from wood processing in the paper industry.

The plasticizers have a retarding effect:

- Plasticizers get adsorbed on the surface of the cement particles and form a thin sheath.
- This sheath inhibits the surface hydration reaction between water and cement as long as sufficient plasticizers molecules are available.

Effects of plasticizers on the properties of concrete

The effect of water-reducing admixtures is dependent on: dosage of the admixture, cement type, aggregate type and grading, mix proportions and temperature.

(Prepared By: Mr. Saurabh, Assistant Professor, civil)

- Workability: Typically, an initial slump in the range 25—75 mm can be increased by 50-60 mm.
- Compressive Strength: The compressive strength of concrete is increased by using water reducing admixtures to reduce water content while maintaining workability. The increase in strength is a direct result of the lower water/cement ratio.

Super Plasticizers: -

In 1960, Japan made a first Super plasticizer and then in 1970 Germany made it. By using Super Plasticizers, we can reduce the 30% of water. It is also called “High Range Water Reducers”. It is strong dispersing agent.

Advantages and disadvantages of Super-plasticizers

The advantages of Super-plasticizers are:

- Significant water reduction
- Reduced cement contents
- Reduce water requirement by 12-30%
- Increased workability of concrete
- Reduced effort required for placement
- More effective use of cement
- More rapid rate of early strength development
- Increased long-term strength
- Reduced permeability of concrete

The disadvantages of Super-plasticizers are:

- Additional admixture cost (the concrete in-place cost may be reduced)
- Slump loss greater than conventional concrete
- Modification of air-entraining admixture dosage
- Less responsive with some cement
- Mild discoloration of light-coloured concrete

Polymers used as super plasticizers

- Sulphonates melamine formaldehyde condensates (SMF)
- Sulphonates naphalene formaldehyde condensates (SNF)
- Modified ligno - sulphonates (MLS)
- Acrylic polymer (AP)
- Poly carboxylate ester (PC)

(Prepared By: Mr. Saurabh, Assistant Professor, civil)

Air Entraining Admixtures: -

Air entraining agent is used to get an air entrained concrete. This air entraining agent produces small air bubbles in concrete and works as ball bearing. So the properties of the concrete like workability, segregation, bleeding ...etc. will change.

Some Air entraining agents: -

- Aluminium Powder
- Hydrogen peroxide
- Alkali salts
- Vegetable Oils and Fats.
- Zinc Powder.
- Natural wood resing ...etc.

Effect of Air entraining agents: -

- Decrease in strength of concrete.
- Decrease in volume of concrete.
- Increase in permeability of concrete.
- Workability increase.
- Decease in Alkali-aggregate reaction.
- Resistance against Sulphate attack.
- Decrease in heat of hydration.

4.6 SILICA FUME CONCRETE

Υ Silica fume is an artificial pozzolana having high pozzolonic activity.

Υ It is a By- product from an electric arc furnace used in manufacture of silicon metal or silicon alloy.

Υ It has high silica content of more than 80%.

Υ It is an excellent for use as a portland cement supplement.

4.6.1 CHEMICAL COMPOSITION

Chemical composition depends on the product being made by the furnace.

Υ Composition is also influenced by the furnace design.

Υ It is mostly made of silica having percentage of more than 80.

(Prepared By: Mr. Saurabh, Assistant Professor, civil)

γ The other chemical composition include $Fe_2O_3, Al_2O_3, CaO, Na_2O, K_2O$ in small percentages.

γ Unlike the other By- products like Fly Ash, Silica fume from a single source has little or no variation in chemical composition from one day to another.

4.6.2 PHYSICAL CHARACTERISTICS

γ It should be in premium white and standard grey colors.

γ The specific gravity of the silica fume concrete is 2.2.

γ Its specific surface area is to be 20,000 sq.meters / kg.

γ Particle size is less than 1 micron with average diameter of 0.1 micron.

γ The shape of the particle is spherical.

γ It should be in Amorphous in nature.

4.6.3 ADVANTAGES OF SILICA FUME

γ High early compressive strength.

γ High tensile flexural strength and modulus of elasticity.

γ Very low permeability to chloride and water intrusion.

γ High bond strength.

γ High electrical resistivity and low permeability.

4.7 Rice husk

- They are the hard-protecting coverings of grains of rice.
- It is used as fuel in the boilers for processing of paddy producing energy through direct combustion and / or by gasification.
- for every 1000 kgs of paddy milled, about 220 kgs (22 %) of husk is produced

(Prepared By: Mr. Saurabh, Assistant Professor, civil)



FIG- RICE HUSK

4.7.1 Applications

- | | | | |
|--------------------------------------|--------------|--------------------------------|----|
| a) High performance concrete | b) Insulator | c) Green concrete | d) |
| Bathroom floors | | e) Industrial factory flooring | f) |
| Concreting the foundation | | g) Swimming pools | |
| h) Water proofing and rehabilitation | | | |

4.7.2 Advantages

- ♣ Improves compressive strength, flexural strength and split tensile strength of concrete when mixed with RHA.
- ♣ RHA mixed with concrete shows better bond strength as compared to OPC concrete.
- RHA makes a role to increase resistance to chemical reactions.
- RHA would result in a reduction of the cost of concrete construction,

(Prepared By: Mr. Saurabh, Assistant Professor, civil)

- Reduction of the environmental greenhouse effects.

4.7.3 Disadvantages

- Suitable incinerator /Furner as well as grinding method is required for burning and grading rice husk in order to obtain good quality ash
- Transportation problem
- Unburnt RHA is not suitable for concrete production

References:

Nawy, E.G., (2008). Concrete Construction Engineering Handbook: Chapter 3 - Chemical Admixtures. by David P. Whitney, DOI: 10.1201/9781420007657.ch3

(Prepared By: Mr. Saurabh, Assistant Professor, civil)

CH-7

Special Concretes

Introduction

- Special concretes are the concrete prepared for specific purpose like light weight, high density, fire protection, radiation shielding etc. concrete is a versatile material possessing good compressive strength. But it suffers from many drawbacks like low tensile strength, permeability to liquids, corrosion of reinforcement, susceptibility to chemical attack and low durability.
- Modification have been made from time to time to overcome the deficiencies of cement concrete. The recent developments in the material and construction technology have led to significant changes resulting in improved performance, wider and more economical use.
- Research work is going on in various concrete research laboratories to get improvement in the performance of concrete.
- Attempts are being made for improvements in the following areas.
 - Improvement in mechanical properties like compressive strength, tensile strength, impact resistance.
 - Improvement in durability in terms of increased chemical and freezing resistances.
 - Improvements in impermeability, thermal insulation, abrasion, skid resistance etc.

1. Different Types of Special Concrete are:

- Lightweight concrete
- High strength concrete
- Fibre reinforced concrete
- Ferrocement
- Ready mix concrete
- Shotcrete
- Polymer concrete
- High performance concrete

2. Difference Between Ordinary and Special Concrete

(Prepared By: Mr. Saurabh, Assistant Professor, civil)

Ordinary Concrete	Special Concrete
Ordinary concrete is used for normal works like building, bridges, road etc.	This type of concrete is used for special type of structures like nuclear reactor, buildings with acoustic treatment, air conditioned buildings etc.
Ingredients of ordinary concrete are cement, sand, aggregate and water.	In case of light weight aggregate concrete, light weight aggregates are used. In polymer concrete, polymer binder is used instead of water.
Construction is carried out by conventional method.	Concreting is done by special techniques
Properties of Concrete like density, strength etc. are of normal range.	Properties of concrete like density strength are of higher range. For example, density of light weight concrete is about 500 to 2000 kg/m ³ and that of heavy weight concrete is about 3000 to 5000 kg.m ³
It is economical	It is costly

Table -1

3. Light Weight Concrete

- The density of conventional concrete is in order of 2200 to 2600 kg/m³. This heavy self-weight will make it uneconomical structural material. The dead weight of the structure made up of this concrete is large compared to the imposed load to be carried. A small reduction in dead weight for structural members like slab, beam and column in high-rise buildings, results in considerable saving in money and manpower.
- Attempts have been made in the past to reduce the self-weight of the concrete to increase the efficiency of concrete as a structural material. The light weight concrete with density in the range of 300 to 1900 kg/ m³ have been successfully developed.



(Prepared By: Mr. Saurabh, Assistant Professor, civil)

Fig-1 Light weight concrete

The Light Weight Concrete Offers the Following Advantage:

- Reduction of Dead Load
- Smaller section of structural members can be adopted. • Lower haulage and handling costs.
- Increase in the progress of work.
- Reduction of foundation costs, particularly in the case of weak soil and tall structures.
- Light weight concrete has a lower thermal conductivity. In case of buildings where air conditioning is to be installed, the use of light weight concrete will result in better thermal comforts and lower power consumption.
- The use of light weight concrete gives an outlet for industrial wastes such as fly ash, clinkers, slag etc. which otherwise create problem for disposal. • It offers great fire resistance.
- Light weight concrete gives overall economy.
- The lower modulus of elasticity and adequate ductility of light weight concrete may be advantageous in the seismic design of structures.

The Light Weight Concrete Is Achieved by Three Different Ways:

- By replacing the normal mineral aggregate, by cellular porous or light weight aggregate.
- By introducing air bubble in mortar this is known as 'aerated concrete'.
- • By omitting sand fraction from the aggregate This is known as 'no fines concrete'.

Natural lightweight aggregate	Artificial lightweight aggregate
(i) Pumice	(i) Artificial cinder
(ii) Diatomite	(ii) Coke breeze
(iii) Scoria	(iii) Foamed slag
(iv) Volcanic cinder	(iv) Bloated clay
(v) Sawdust	(v) Expanded shales and slate
(vi) Rice husk	(vi) Sintered fly ash
	(vii) Expanded perlite

Table -2

Light Weight Aggregates

Natural light weight aggregate:

(Prepared By: Mr. Saurabh, Assistant Professor, civil)

- Pumice: These are rocks of volcanic origin. They are light coloured or nearly white and has a fairly even texture of interconnected voids. Its bulk density is 500 – 800 kg/ m³.
- Scoria: Scoria is light weight aggregate of volcanic origin, they are dark in colour It is slightly weaker than pumice.
- Rice Husk: Use of rice husk or groundnut husk has been reported as light weight aggregate.
- Saw dust: Saw dust is used as light weight aggregate in the flooring and in the manufacture of precast elements. But the presence of carbohydrates in the wood, adversely affect the setting and hardening of Portland cement.
- Diatomite: It is derived from the remains of microscopic aquatic plants called diatoms. It is also used as a pozzolanic material.



Fig-2

Natural light weight aggregate: Pumice Scoria Rice Husk Saw Dust Diatomite

Artificial Light Weight Aggregates:

- **Sintered flash (Pulverized fuel ash):** The fly ash collected from modern thermal power plants burning pulverized fuel, is mixed with water and

(Prepared By: Mr. Saurabh, Assistant Professor, civil)

coal slurry in screw mixers and then fed on to rotating pans, known as pelletizers, to form spherical pellets. The pellets are then fed on to a sinster strand at a temperature of 1000 0C to 1200 0C. Due to sintering the fly ash particles coagulate to form hard brick like spherical particles. The produces material is screened and graded. In UK it is sold by the trade name ' Lytag'.

- **Foamed Slag:** Foamed slag is a by-product produced in the manufacture of pig iron. It is a porous, honeycombed material which resembles pumice.



fig-3

- **Bloated Clay:** When special grade of clay and shales are heated to the point of incipient fusion, there will be expansion due to formation of gas within the mass. The expansion is known as bloating and the product so formed is used as light weight aggregate.



fig-4

- **Exfoliated vermiculite:** The raw vermiculite material resembles mica in appearance and consists of thin flat flakes containing microscopic particles of water. On heating with certain percentage of water it expands by delamination in the same way as that of slate or shale. This type of expansion is known as exfoliation. The concrete made with vermiculate as aggregate will have very low density and very low strength.

- **Ciders, clinkers, breeze:** The partly fused or sintered particles arising from the combustion of coal, is termed as cinder or clinker or breeze. Cinder aggregate undergo high drying shrinkage and moisture

(Prepared By: Mr. Saurabh, Assistant Professor, civil)

movement. These are used for making building blocks for partition walls, for making screening over flat roofs and for plastering purposes.



No Fines Concrete

- 'No fines concrete' is obtained by omitting fine aggregate fraction (below 12 mm) from the conventional concrete. It consists of cement, coarse aggregates and water only. Cement Content is correspondingly increased. Very often only single sized coarse aggregate, of size passing through 20 mm and retained on 10 mm is used. By using single sized aggregate, voids can be increased. The actual void content may vary between 30 to 40 percent depending upon the degree of consolidation of concrete.
- No fines concrete is generally made with the aggregate/ cement ratio 6:1 to 10:1. The water/ cement ratio for satisfactory consistency will vary between 0.38 to 0.50. The strength of no fines concrete is dependent on the water/ cement ratio, aggregate/ cement ratio and unit weight of concrete
- When conventional aggregate is used, no-fines concrete show a density of about 1600 to 2000 kg/ m³. but by using light weight aggregate, the density may reduce to about 350 kg/m³. Through the strength of no fines concrete is lower than ordinary concrete, the strength is sufficient for use in structural members and load bearing wall in normal buildings up to 3 stories high. Strengths of the order of 15 N/mm² have been attained with no fines concrete. The bond strength of no-fines concrete is very low and therefore, reinforcement is not used in no-fines concrete. However, if reinforcement is required to be used in no fines concrete, it is advisable to smear the reinforcement with cement paste to improve the bond strength and to protect it from rusting.

(Prepared By: Mr. Saurabh, Assistant Professor, civil)



Fig-7 No Fines Concrete

Advantages of Lightweight Concrete:

- a) Reduced dead load of the concrete allows longer span. This saves both labour and time.
- b) Screeds and walls where timber has to be attached by nailing.
- c) Casting structural steel to protect it against fire and corrosion or as a covering for architectural purposes.
- d) Gives heat insulation on roofs.
- e) Used in insulation of water pipes.
- f) Construction of partition walls and panel walls in frame structures.
- g) Fixing bricks to receive nails from joinery, mainly in domestic or domestic type construction.
- h) General insulation of walls.
- l) It is also being used for reinforced concrete.

4. HIGH STRENGTH CONCRETE

- High strength concrete can be defined by compressive strength of concrete at 28 days of water curing.
- When the grade of concrete exceeds M35, then the concrete may be called as high strength concrete.
- In general, producing of HSC is difficult with the use of conventional materials like cement, aggregate and water alone and it can be achieved by using of chemical and mineral admixtures or any one of the following methods.
 - (a) Seeding
 - (b) Re vibration

(Prepared By: Mr. Saurabh, Assistant Professor, civil)

- (c) High speed slurry mixing
- (d) Use of admixtures
- (e) Inhibition of cracks
- (f) Sulphur Impregnation
- (g) Use of cementitious aggregates

A. Seeding:

- In this method, small percentage of finely ground, fully hydrated Portland cement is added to fresh concrete mix.

B. Re vibration:

- Mixing water to concrete mix creates continuous capillary channels, bleeding and accumulates of water at some selected places. All these reduce the strength of concrete.
- Hence controlled re-vibration is given after suitable time and it is increasing the strength of concrete.

C. High speed slurry mixing:

- This process involves advanced preparation of cement water mixture which is then blended with aggregate to produce HSC

(d) Use of admixtures:

The high strength can be achieved by adding chemical admixtures such as super plasticizer and mineral admixtures such as fly ash, silica fume etc...

(e) Inhibition of cracks:

- Inhibition or arresting of crack is needed to improve the strength of concrete.
- Normally, it is achieved by replacing 2-3% of fine aggregate (polythene of 0.025 mm thick and 3 to 4 mm in diameter).
- The polythene is act as a crack arrester. By this method the strength is much improved up to 105 MPa

(f) Sulphur Impregnation:

- Satisfactory high strength concrete has been produced by impregnating low strength porous concrete by sulphur.
- The process consists of the harden concrete (drying them at 120° C for 24 hours), immersing in molten sulphur under vacuum for 2 hours.
- By this method the strength is improved up to 58 MPa.

(g) Use of cementitious aggregates:

- Some kind of clinkers are used as aggregate in concrete and is called cementitious aggregate (E.g. ALAG).
- It gives high strength to the concrete up to 125 MPa with very low water cement ratio of 0.32.

(Prepared By: Mr. Saurabh, Assistant Professor, civil)

5. Fibre Reinforced Concrete (FRC)

• Fibre reinforced concrete (FRC) can be defined as a composite material consisting of concrete and discontinuous, discrete, uniform dispersed fine fibres. The continuous meshes, woven fabrics and long wires or rods are not considered to be discrete fibres. • The inclusion of fibres in concrete and shotcrete generally improves material properties like ductility, flexural strength, toughness impact resistance and fatigue strength. There is little improvement in compressive strength. The type and amount of improvement in compressive strength. The type and amount of improvement is dependent upon the fibre type, size, strength and configuration and amount of fibre

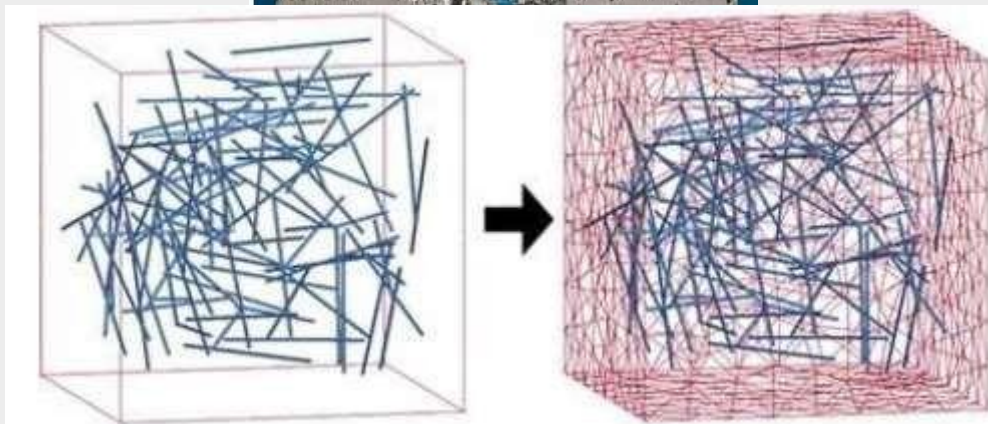

FIG-Fibre Reinforced Concrete (FRC)-8-(A, B, C)

Types of fibre:

Following are the different type of fibres generally used in the construction industries.

1. Steel Fibre
2. Polypropylene Fibre
3. GFRC Glass Fibre
4. Asbestos Fibres
5. Carbon Fibres
6. Organic Fibres

(Prepared By: Mr. Saurabh, Assistant Professor, civil)

7. Natural fibre (Coir fibre, Cotton fibre, Sisal fibre, Jute fibre and Wool fibre)

- Fibre is a small discrete reinforcing material produced from steel, polypropylene, nylon, glass, asbestos, coir or carbon in various shape and size. They can be circular or flat.

Steel fibres: Steel fibre is one of the most commonly used fibre. They are generally round. The diameter may vary from 0.25 mm to 0.75 mm. The steel fibre is likely to get rusted and lose some of its strength. Use of steel fibre makes significant improvements in flexural impact and fatigue strength of concrete.

- Steel fibres have been extensively used in overlays or roads, pavements, air fields, bridge decks, thin shells and floorings subjected to wear and tear and chemical attack.

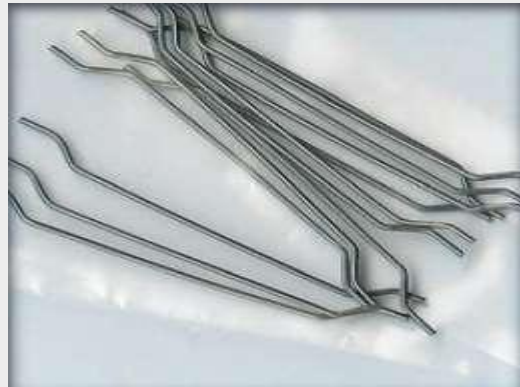

FIG-9 Steel Fibres

Glass Fibres: These are produced in three basic forms:

- (a) Roving's • (b) Strands • (c) Woven or chopped strand mats.

- Major problems in their use are breakage of fibre and the surface degradation of glass by high alkalinity of the hydrated cement paste. However, alkali resistant glass fibre has been developed now. Glass fibre reinforced concrete (GFRC) is mostly used for decorative application rather than structural purposes.

- With the addition of just 5 % glass fibers, an improvement in the impact strength of up to 1500 % can be obtained as compared to plain concrete. With the addition of 2 % fibers the flexural strength is almost doubled.

(Prepared By: Mr. Saurabh, Assistant Professor, civil)



FIG-10 Glass Fibers

Plastic fibers: Fibers such as polypropylene, nylon, acrylic, aramid and polyethylene have high tensile strength thus inhibiting reinforcing effect. Polypropylene and nylon fibers are found to be suitable to increase the impact strength. Their addition to concrete has shown better distribute cracking and reduced crack size.



FIG-11

Carbon Fibers: Carbon fibers possess high tensile strength and high young's modulus. The use of carbon fibre in concrete is promising but is costly and availability of carbon fibre in India is limited.

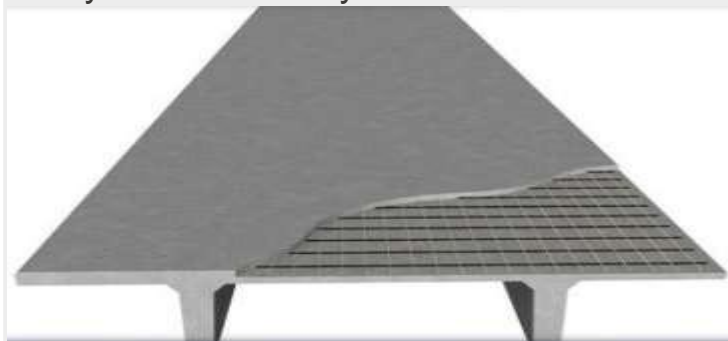

FIG-12 Carbon Fiber

Asbestos fibers: • Asbestos is a mineral fibre and has proved to be most successful fibre, which can be mixed with OPC. The maximum length of asbestos fibre is 10 mm but generally fibers are shorter than this. The composite has high flexural strength.

(Prepared By: Mr. Saurabh, Assistant Professor, civil)



FIG-13 Asbestos fibers

Factors Affecting Properties of Fiber Reinforced Concrete The important factors affecting properties of FRC are as follows:

- Volume of fibers
- Aspect ratio of fibers
- Orientation of fibers
- Size of coarse aggregate
- Workability and compaction of Concrete
- Mixing

Necessity of Fiber Reinforced Concrete:

- a) It increases the tensile strength of the concrete.
- b) It reduces the air voids and water voids the inherent porosity of gel.
- c) It increases the durability of the concrete.
- d) Fibres such as graphite and glass have excellent resistance to creep.
- e) Differential deformation is minimized
- f) It has been recognized that the addition of small, closely spaced and uniformly dispersed fibers to concrete would act as crack arrester
- g) It substantially improves its static and dynamic properties.

6. FERROCEMENT

“Ferro cement is a type of thin wall reinforced concrete, commonly constructed of hydraulic cement mortar, reinforced with closely spaced layers of continuous and relatively small size wire mesh. The mesh may be made of metallic or other suitable materials.”

Materials for ferrocement

- a) Cement mortar mix
- b) Skeleton steel
- c) Steel mesh reinforcement

(Prepared By: Mr. Saurabh, Assistant Professor, civil)



Fig-14 ferro concrete

Advantages of ferrocement

- It is highly versatile and can be formed into almost any shape for a wide range of uses
- 20% savings on materials and cost
- Suitability for pre-casting
- Flexibility in cutting, drilling and jointing
- Very appropriate for developing countries; labour intensive
- Good fire resistance
- Good impermeability
- Low maintenance costs
- Reduction in self-weight & Its simple techniques require a minimum of skilled labour
- Reduction in expensive form work so economy & speed can be achieved
- Only a few simple hand tools are needed to build any structures
- Structures are highly waterproof & Higher strength to weight ratio than R.C.C

7. READY MIX CONCRETE

“Ready mix concrete is concrete mixed away from the construction site and then it is delivered to the construction site by the truck in a ready-to-use condition is called ready mix concrete.”

Advantages of Ready Mixed Concrete:

- Concrete is produced under controlled conditions using consistent quality of raw material.
- Speed of construction can be very fast in case RMC is used.
- Reduction in cement consumption by 10 – 12 % due to better handling and proper mixing.

(Prepared By: Mr. Saurabh, Assistant Professor, civil)

- The mix design of the concrete can be tailor made to suit the placing methods of the contractor.
- Since ready mixed concrete (RMC) uses bulk cement instead of bagged cement, dust pollution will be reduced
- Conservation of energy and resources because of saving of cement.
- Environment pollution is reduced due to less production of cement.
- Better durability of structure
- Minimizing human error and reduction in dependency on labour.
- Timely deliveries in large as well as small pours.
- No need for space for storing the materials.
- Reduced noise and air pollution; less consumption of petrol and diesel and less time loss to business.



FIG-15 RMC

8. SHOTCRETE or GUNITE

Process of conveying dry (or damp) sand and cement by means of compressed air through material hose to a nozzle where water is added before the material is sprayed on the construction surface is called shotcrete or Guniting.

Methods:

- Dry mix - In this dry mix the cement and sand is mixed thoroughly in dry state
- Wet mix - Concrete is mixed with water before conveying through delivery pipe and not suitable like dry mix

(Prepared By: Mr. Saurabh, Assistant Professor, civil)

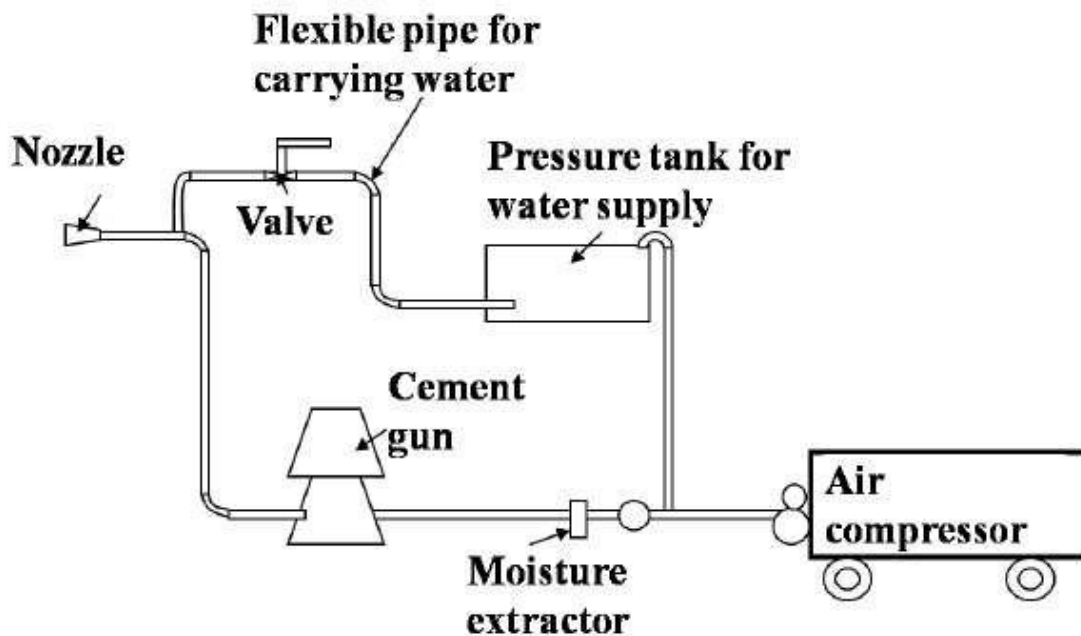

FIG-16 SHOTCRETE

Procedure of shotcrete on surface:

- Thoroughly clean all surfaces to receive shotcrete by removing
 - loose materials and dust, pressure washing and dampen the surface to a saturated surface dry condition.
 - Fix wire mesh to the concrete surface. The steel wire mesh has to be placed in position keeping the mesh within 10-15 mm from the surface. Suitable fixing pins are to be inserted to keep the mesh in proper position and to ensure that the weld mesh is not disturbed during shotcreting.
 - Prepare a cement-sand / water mix and pour this mix into Pump
 - hose for lubrication before starting to pump the production mixture
 - When the pumped mixture reaches the nozzle, turn on compressed air.
 - Apply shotcrete evenly to targeted surfaces. Built-up the desired
 - thickness of shotcrete in layers of about 30 mm thick each. The
 - presence of voids can be found by hollow hammering sound after
 - the shotcrete has attained strength after around 3 days.

8.3 Application of Shotcrete:

- Shotcrete can be used to repair the damaged surface of concrete
- Shotcrete repair can be used for bridge deck rehabilitation

(Prepared By: Mr. Saurabh, Assistant Professor, civil)

- repair of fire and earthquake damage and deterioration, strengthening walls.
- To marine structures can result from deterioration of the concrete and of the reinforcement.
- Shotcrete is used in underground excavations in rock
- used for temporary protection of exposed rock surfaces that will deteriorate when exposed to air to construct concrete swimming pools.
- Shotcrete floors in tanks and pools on well compacted sub-base

9.POLYMER CONCRETE

Polymer concrete is nothing but impregnations of monomer into the pores of harden concrete and then getting it polymerized by thermal process is called polymer concrete.

By this polymerization, the strength of the concrete is much improved.

Types of polymer concrete:

- Polymer Impregnated concrete
- Polymer cement concrete
- Polymer concrete
- Partially impregnated and surface coated polymer concrete

Types of monomer:

- Methyl methacrylate
- Styrene
- Acrylonitrile
- T-butyl styrene
- Thermoplastic monomer

Advantages of polymer concrete:

- It has high impact resistance and high compressive strength.
- Polymer concrete is highly resistant to freezing and thawing.
- Highly resistant to chemical attack and abrasion.
- Permeability is lower than other conventional concrete.

Application of polymer concrete:

- Nuclear power plants.
- Kerbstones.
- Prefabricated structural element.
- Precast slabs for bridge decks.
- Roads.
- Marine Works.
- Prestressed concrete.
- Irrigation works.
- Sewage works.

(Prepared By: Mr. Saurabh, Assistant Professor, civil)

- Waterproofing of buildings.
- Food processing buildings etc.

Questions

- State different types of special concrete and describe light weight concrete. (May 2011)
- Describe polymer concrete and its application (March 2010)
- ♣ High Strength Concrete ♣ Heavy weight concrete ♣ Fiber reinforced concrete ♣ Polymer Concrete ♣ Mass Concrete ♣ Plum Concrete ♣ Aerated Concrete ♣ Ferro cement

References

Concrete Technology by: R.P. Rethaliya - Atul Prakashan • Concrete Technology by . M.S. Shetty • Internet websites

(Prepared By: Mr. Saurabh, Assistant Professor, civil)

CH-8-CONCRETE OPERATION

CONCRETING OPERATIONS

The operations which are followed in actual practice in the making of concrete and in improving and maintaining the quality of concrete are known as concreting operations.

The following operations are involved in concrete making:

- Storing of materials
- Batching of materials
- Mixing of various ingredients
- Transportation of concrete mix
- Placing of concrete
- Compaction of concrete
- Finishing of concrete surface
- Curing of concrete
- Joints in concrete.

1. Storing of concrete materials

The process of keeping the ingredients of concrete in their proper place to protect them from the effect of weathering is called storing.

OBJECT TO STORING

Maintaining the quality and grading of materials is the main objective of storage of materials. Every effort should be made that the quality of cement do not deteriorate during storage in warehouses or at the site of work.

Storage of cement

Cement is a finely ground material. It is highly hygroscopic. It absorbs moisture which may be in the form of free water. An absorption of 1 to

(Prepared By: Mr. Saurabh, Assistant Professor, civil)

2% of water has no effect, but further amount of absorption reduces the strength of cement. If the absorption exceeds 5% the cement is, for all ordinary purposes ruined. During the storing and transporting of cement, care is always taken to keep it away from moisture.

METHOD OF STORING CEMENT IN WAREHOUSE

- The cement bags should be placed directly over the floor if it is dry and if not, then the bags should be placed on a raised platform made of wooden planks.
- The space between the exterior walls and piles should be 0.30 m (A group of number of bags arranged together closely is called pile.)
- Bags should be placed close together to avoid circulation of air.
- The height of pile should not be more than 2.7m i.e. not more than 15 bags should be placed one above the other. The width of pile should not be more than 3m.
- The cement bags should be placed in header course and stretcher course alternatively if height of pile exceeds 1.44m (i.e. 8 bags). The bags are arranged to avoid danger of over toppling of cement bags.
- Cement bags should not be removed on the principle of first in and first out. For this purpose, each consignment should be piled separately and date plates should be kept for showing date of arrival.
- Main requirement is weather-proof building or shed with following properties:
- Walls having water-proof masonry construction.
- The roof should be R.C.C. or leak-proof.
- The windows should be few and small in sizes and kept shut. This is to prevent moisture ingress.
- Dry Coarse of Soling.

(Prepared By: Mr. Saurabh, Assistant Professor, civil)

- The floor should be preferably of concrete of 15 cms. thick. Care should be taken to drain away rain water to protect the floor from dampening.
- Accumulation of water around the godown or shed, shall be avoided. Cement bags should not be stored against the wall. A space of 40 cms. should kept between wall and stacks.
- Cement bags should be stored from level of 15-20 cms. above the floor level by providing wooden planks to avoid penetration of moisture. Sometimes owing to pressure on lower layer of the bags warehouse pack or pack-set can develop in the bags. This can be avoided by not stacking more than 10 bags high for white cement & not stacking more than 20 bags high for grey cement.

Temporary Storage at Site

Sometimes cement requirement of a day or two may have to be stored at site in the open. In such cases cement bags should be laid on a dry platform made of wooden planks resting over brick-masonry concrete, dry sand aggregates raised about 15 cms. above the ground level. The stack must be kept fully covered with tarpaulin or polythene sheet and protected against atmospheric moisture. Temporary storage or open storage should not be adopted in wet weather.

Removal of Cement Bags

- When the bags are required to be removed for use, follow the 'First In First Out' rule (FIFO system) i.e. the oldest cement to be used first. For this purpose, each consignment of cement should be stacked separately and identified by a placard bearing the date of arrival.
- Remove the bags from two or three tiers at the back.
- Do not remove bags from only one tier in the front.

(Prepared By: Mr. Saurabh, Assistant Professor, civil)

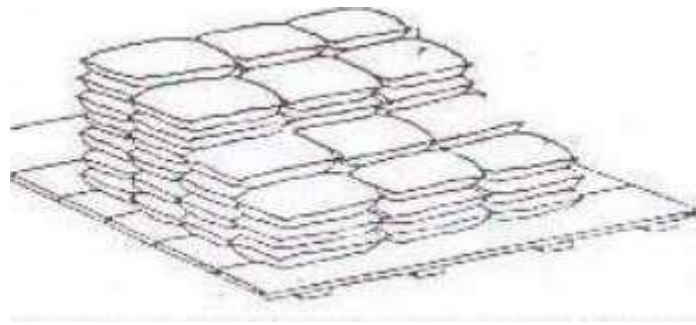

Fig-1stepping of tiers while removing cement begs

1.2.4 Effect of Storage on Strength of Cement

The cement when stored for longer period of time loses its strength characteristics. The strength of cement when used after one year of its production loses its strength by about 30-40% on application as compared to that of freshly produced cement.

Approximate reduction in strength with age (in standard water tight storage condition)

SL No.	Age in months	Loss of Strength (%)
1.	3	5 to 10
2.	6	20 to 30
3.	12	30 to 40

table-1

1.3 STORING OF AGGREGATES

Storing of aggregates should be done in such a way as to: -

- ▶ Maintain the uniformity of grading
- ▶ Prevent segregation
- ▶ Maintain uniform surface water condition

(Prepared By: Mr. Saurabh, Assistant Professor, civil)

- ▶ Avoid mixing of harmful material in the aggregate.

1.3.1 Precautions for maintaining uniformity of grading

- ▶ Hard and dry patch of ground should be selected for storing of the aggregate. If a hard surface is not available, provide a platform of planks, G.I. sheets, floor of bricks or a weak concrete layer. This platform is used to avoid the mixing of soil with the aggregates.
- ▶ The aggregates of various sizes should be kept separately. Piles of sand and coarse aggregate should be kept separate.

PRECAUTIONS FOR PREVENTION OF SEGREGATION

- ▶ During stock piling successive consignments should not be dropped on the same place to form a pyramid. It will lead to segregation i.e. the coarser material rolls down the sides of piles and fine material will concentrate in the centre.
- ▶ The aggregates should be placed in layer not thicker than one truck dumped at same place.
- ▶ The aggregates should not fall from a height while being transported and dumped.
- ▶ The pile should be as near as possible to the mixer to avoid greater distance of transport.

PRECAUTIONS FOR PRESERVING UNIFORMITY OF MOISTURE CONTENT

- ▶ The area occupied by each pile should be as large as possible. The height of pile should be from 1.25m to 1.75m.
- ▶ The pile should be allowed to stand for 24 hours at least before being used so that the moisture has time to settle.
- ▶ In the case of sand, the bottom layer (last 300mm) should not be used as the bottom layer becomes saturated with water.

PRECAUTIONS FOR CLEANLINESS OF AGGREGATES.

The piles of aggregates should be kept clean of leaves, bidis, vegetable debris, animal refuse etc.

(Prepared By: Mr. Saurabh, Assistant Professor, civil)

STORING OF WATER

Water is stored at site in a masonry tank built for the purpose or in other clean containers. The walls of the tank should be somewhat higher than the surrounding ground. Sufficient quantity of water should be stored in advance to ensure the continuity of concreting operations. If the water obtained from a source contains dust etc. it should be collected a day in advance to allow such suspended impurities to settle down before use.

BATCHING

The process of measurement of ingredients (cement, fine aggregate, coarse aggregate and water) for making concrete is called batching. Batching is done in two ways: -

- 1) Volume batching
- 2) Weigh batching

1.5.1 Volume batching

(a) Batching of cement: -Cement is always batched by weight. Cement should never be batched by volume, because its weight per unit volume varies according to the way container (forma) is filled.

(b) Batching of aggregates: - Wooden batch boxes known as formas are used for batching of fine and coarse aggregates by volume. The formas should be made of 30 mm thick timber.

(c) Batching of water: -It is practice in the field to add water by tin cans or buckets. It is not an accurate method. It results in variable strength of concrete.

Some of mixers are equipped with calibrated water tank attached permanently to the mixers. For the mixers not provided with water tank calibrated syphon system can be easily got installed, such as the one used in cisterns of water closets. If, however, there are no such automatic devices, water should be measured in calibrated cans very accurately and then only should be added in the mixer.

(Prepared By: Mr. Saurabh, Assistant Professor, civil)

	Cement kg.	Sand, litres	Coarse aggregate, litres
1 : 1 : 2 (M 200)	50	35	70
1 : 1 1/2 : 3 (M 200)	50	52.5	105
1 : 2 : 3	50	70	105
1 : 2 : 4 (M 150)	50	70	140
1 : 2 1/2 : 5	50	87.5	175
1 : 3 : 6 (M 100)	50	105	210

Water is measured either in kg. or litres as may be convenient. In this case, the two units are same, as the density of water is one kg. per litre. The quantity of water required is a product of water/cement ratio and the weight of cement; for a example, if the water/cement

TABLE-2 BATCH VOLUME OF VARIOUS BATCH MIXES

Weigh Batching:

Strictly speaking, weigh batching is the correct method of measuring the materials. For important concrete, invariably, weigh batching system should be adopted. Use of weight system in batching, facilitates accuracy, flexibility and simplicity. Different types of weigh batchers are available, the particular type to be used, depends upon the nature of the job. Large weigh batching plants have automatic weighing equipment. The use of this automatic equipment for batching is one of sophistication and requires qualified and experienced engineers. In this, further complication will come to adjust water content to cater for the moisture content in the aggregate. In smaller works, the weighing arrangement consists of two weighing buckets, each connected through a system of levers to spring-loaded dials which indicate the load.



Weigh Batcher

Fig-2

(Prepared By: Mr. Saurabh, Assistant Professor, civil)

MIXING OF CONCRETE

The process of mixing of various ingredients of concrete in specified proportions is termed as mixing of concrete.

Methods of mixing: -

There are two methods of mixing:

- (a) Hand mixing
- (b) Machine mixing

HAND MIXING The process of mixing the ingredients of concrete by manual labour is called hand mixing. The process of mixing the ingredients of concrete by manual labour is called hand mixing. Hand mixing is adopted for small and unimportant works and where quantity of concrete used is small. Hand mixing method requires more cement(10%more) than machine mixing for obtaining the small strength of concrete.

FOLLOWING IS STEP WISE PROCEDURE FOR MIXING BY HAND

- ▶ A platform of bricks, lean concrete or iron sheets is constructed. The size of the platform depends upon the quantity of concrete to be mixed at a time.
- ▶ Spread out a measured quantity of sand evenly on the mixing platform. ▶ Spread the cement uniformly on this sand and mix it till the colour of mixture is uniform.
- ▶ Spread this mixture evenly again on platform.
- ▶ Spread the measured coarse aggregate evenly on the mixing platform. ▶ Mix the material dry.
- ▶ Make a hollow in the centre of the mixed material. After this 75% of the required quantity of water based on water-cement ratio is added and then start remixing taking care that no water escapes the mixture.
- ▶ The remaining water is added with the continuation of mixing process.
- ▶ Normally mixing time should not exceed 3 min.

(Prepared By: Mr. Saurabh, Assistant Professor, civil)

► The platform should be cleaned at the end of day's work so that it is ready for use on the next day.

MACHINE MIXING

The process of mixing the ingredients of concrete by a machine is called machine mixing. The process of mixing the ingredients of concrete by a machine is called machine mixing.

In this case where a large quantity of concrete is to be produced, hand mixing becomes costly even if the labour is cheap. The machine mixing becomes essential. The concrete can thus be produced at a faster rate and at a lesser cost. The quantity of concrete by machine mixing is also better.



Modern ready mixed concrete plant.

Fig-3

1.7 TRANSPORTATION OF CONCRETE

The process of carrying concrete mix from the place of its mixing to final position or deposition is called transportation of concrete. The process of carrying concrete mix from the place of its mixing to final position or deposition is called transportation of concrete.

Transportation of concrete mix is very important because in transportation, time factor is involved. The mix should be transported as quickly as possible.

(Prepared By: Mr. Saurabh, Assistant Professor, civil)

Precaution in Transportation of concrete

The following precaution should be taken during transporting concrete from the mixing place:

- ▶ Concrete should be transported as quickly as possible to the formwork within the initial setting time of cement.
- ▶ Efforts should be made to prevent segregation. ▶ Transportation cost should be as low as possible.
- ▶ The concrete mix should be protected from drying in hot weather and from rain during transportation.
- ▶ The concrete should be kept agitated in truck mixer so that it does not become stiff when transportation is likely to take more time.
- ▶ No water should be lost from the mix during transportation.
- ▶ The permissible duration of transport of concrete should be determined in the laboratory.

The methods adopted for transportation of concrete are:

- (a) Mortar Pan
- (b) Wheel Barrow, Hand Cart
- (c) Crane, Bucket and Rope way
- (d) Truck Mixer and Dumpers
- (e) Belt Conveyors
- (f) Chute
- (g) Skip and Hoist
- (h) Transit Mixer
- (l) Pump and Pipe Line
- (j) Helicopter

Concrete Pumps:

(Prepared By: Mr. Saurabh, Assistant Professor, civil)

The modern concrete pump is a sophisticated, reliable and robust machine. In the past a simple two-stroke mechanical pump consisted of a receiving hopper, an inlet and an outlet valve, a piston and a cylinder. The pump was powered by a diesel engine.

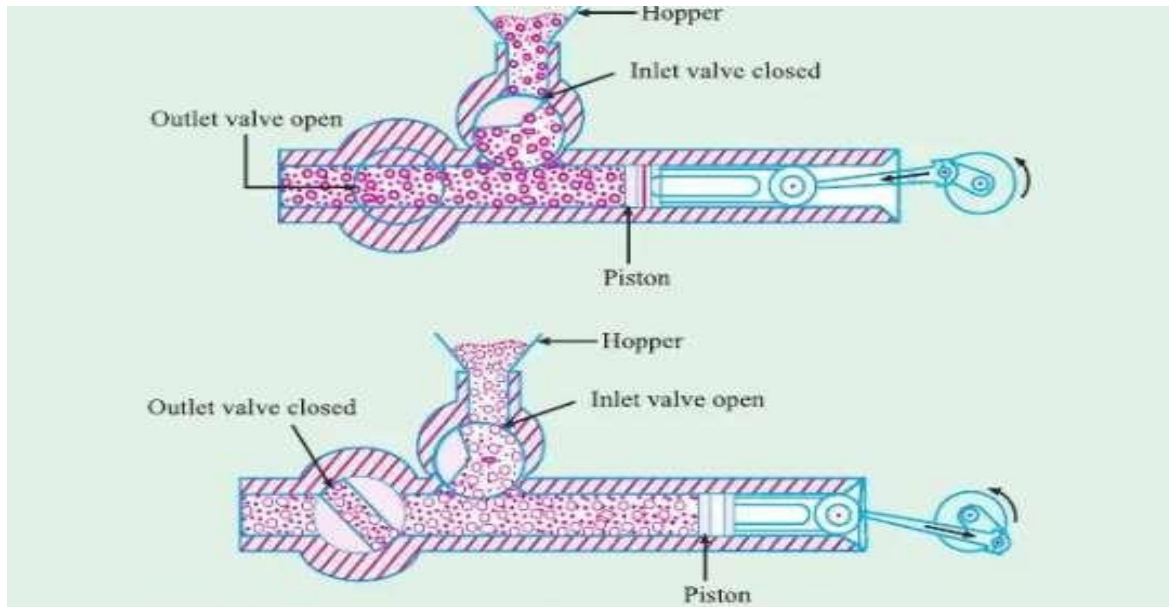

Fig-5 direct acting pumps

1.8.1 Choosing the Correct Pump

For choosing the correct pump one must know the following factors

- Length of horizontal pipe
- Length of vertical pipe
- Number of bends
- Diameter of pipeline
- Length of flexible hose
- Changes in line diameter
- Slump of Concrete

1.9 Placing Concrete

It is not enough that a concrete mix correctly designed, batched, mixed and transported, it is of utmost importance that the concrete must be placed in systematic manner to yield optimum results. The precautions

(Prepared By: Mr. Saurabh, Assistant Professor, civil)

to be taken and methods adopted while placing concrete in the under-mentioned situations, will be discussed

- a) Placing concrete within earth mould. (example: Foundation concrete for a wall or column).
- b) Placing concrete within large earth mould or timber plank formwork. (example: Road slab and Airfield slab).
- c) Placing concrete in layers within timber or steel shutters. (example: Mass concrete in dam construction or construction of concrete abutment or pier).
- d) Placing concrete within usual formwork. (example: Columns, beams and floors).
- e) Placing concrete under water



Fig-6 placing of concrete

Placing concrete within earth mould

- Concrete is invariably as foundation bed below the walls and columns before placing concrete
- All loose earth must be removed.
- Roots of trees must be cut.
- If surface is dry, it should be made damp.
- If it is too wet or rain soaked the water, then slush must be removed

(Prepared By: Mr. Saurabh, Assistant Professor, civil)

Placing concrete in layers with in timber or steel shutter :-

- This can be used in the following cases
- Dam construction
- Construction of concrete abutments
- Raft for a high-rise building
- The thickness of layers depends on
- Method of compaction
- Size of vibrator
- Frequency of vibrator used
- It is good for laying 15 to 30 cm thick layer of concrete, for mass concrete it may vary from 35 to 45 cm.
- It's better to leave the top of the layer rough so that succeeding layer can have the good bond.

Placing concrete with in usual form work:-

- Adopted for column, beam and floors rules that should be followed while placing the concrete.
- Check the reinforcements are correctly tied and placed.
- Mould releasing agent should be applied.
- The concrete must be placed carefully with a small quantity at a time so that they will not block the entry of subsequent concrete.

Placing concrete under water: -

- Concrete having cement content at least 450kg/m³ and a slump of 10 to 17.5cm can be placed underwater.

Methods: -

1. Bagged method
2. Bottom dump method

(Prepared By: Mr. Saurabh, Assistant Professor, civil)

3. Tremie

4. Grouted aggregate

5. Concrete pump

Placing Concrete Under water: - Used: Tremie

- Advantages: Can be used to funnel concrete down through the water into the structure.
- Watch for: Discharge end always has to be buried in fresh concrete to ensure seal between water and concrete mass.

1.10 Form work:

Form work shall be designed and constructed so as to remain sufficiently rigid during placing and compaction of concrete. The joints are plugged to prevent the loss of slurry from concrete.

Stripping Time: Formwork should not be removed until the concrete has developed a strength of at least twice the stress to which concrete may be subjected at the time of removal of formwork. In special circumstances the strength development of concrete can be assessed by placing companion cubes near the structure and curing the same in the manner simulating curing conditions of structures. In normal circumstances, where ambient temperature does not fall below 15°C and where ordinary Portland cement is used and adequate curing is done, following striking period can be considered sufficient as per IS 456 of 2000.

(Prepared By: Mr. Saurabh, Assistant Professor, civil)

Sr. No.	Type of Formwork	Minimum period before striking formwork
1.	Vertical formwork to columns walls and beams	16 - 24 hours
2.	Soffit formwork to slabs (props to be refixed immediately after removal of formwork)	3 days
3.	Soffit formwork to beams (Props to be refixed immediately after removal of formwork)	7 days
4.	Props to slab spanning up to 4.5 m	7 days
	spanning over 4.5 m	14 days
5.	Props to beam and arches Spanning up to 6 m	14 days
	Spanning over 6 m	21 days

Note: For other cements and lower temperature, the stripping time recommended above may be suitably modified.

Table -3 stripping time for form work

1.11 Compaction of Concrete

Compaction of concrete is the process adopted for expelling the entrapped air from the concrete. In the process of mixing, transporting and placing of concrete air is likely to get entrapped in the concrete. The lower the workability, higher is the amount of air entrapped. In other words, stiff concrete mix has high percentage of entrapped air and, therefore, would need higher compacting efforts than high workable mixes.

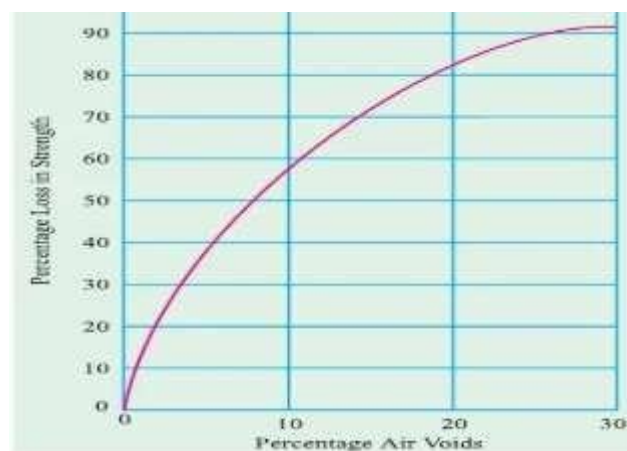

fig-7

The following methods are adopted for compacting the concrete:

(Prepared By: Mr. Saurabh, Assistant Professor, civil)

- (a) Hand Compaction
 - (i) Rodding
 - (ii) Ramming
 - (iii) Tamping
- (b) Compaction by Vibration
 - (i) Internal vibrator (Needle vibrator)
 - (ii) Formwork vibrator (External vibrator)
 - (iii) Table vibrator
 - (iv) Platform vibrator
 - (v) Surface vibrator (Screed vibrator)
 - (vi) Vibratory Roller.
- (c) Compaction by Pressure and Jolting
- (d) Compaction by Spinning.

Hand Compaction: - Hand compaction is used for ordinary and unimportant structures. Workability should be decided in such a way that the chances of honeycombing should be minimum. The various methods of hand compaction are as given below:

□ Rodding: -

It is a method of poking with 2m long, 16 mm dia. rod at sharp corners and edges. The thickness of layers for rodding should be 15 to 20 cm.

(Prepared By: Mr. Saurabh, Assistant Professor, civil)



fig-8

□ Ramming: - It is generally used for compaction on ground in plain concrete. It is not used either in RCC or on upper floors.



fig-9

□ Tamping: - It is a method in which the top surface is beaten by wooden cross beam of cross section 10 cm x 10 cm.

- Both compaction and levelling are achieved simultaneously.
- It is mainly used for roof slabs and road pavements.



fig-10

Compaction by Vibration:

(Prepared By: Mr. Saurabh, Assistant Professor, civil)

- Vibration is imparted to the concrete by mechanical means.
- It causes temporary liquefaction so that air bubbles come on to the top and expelled ultimately.
- Mechanical vibration can be of various types as given under.

□ Internal Vibration:

- It is most commonly used technique of concrete vibration.
- Vibration is achieved due to eccentric weights attached to the shaft.
- The needle diameter varies from 20 mm to 75 mm and its length varies from 25 cm to 90 cm.
- the frequency range adopted is normally 3500 to 5000 rpm.

External Vibration

- This is adopted where internal vibration can't be used due to either thin sections or heavy reinforcement.
- External vibration is less effective and it consumes more power as compared to the internal vibration.
- The formwork also has to be made extra strong when external vibration is used.



fig-11

Table Vibration: -

- It is mainly used for laboratories where concrete is put on the table

(Prepared By: Mr. Saurabh, Assistant Professor, civil)



fig-12

Platform Vibration: -

- It is similar to table vibrators but these are generally used on a very large scale



fig-13

Surface Vibration: -

- These are also called screed board vibrators.
- The action is similar to that of tamping.
- The vibrator is placed on screed board and vibration is given on the surface.
- It is mainly used for roof slabs, road pavements etc., but it is not effective beyond 15 cm depth.

(Prepared By: Mr. Saurabh, Assistant Professor, civil)



fig-14

1.12 Curing: -

- **Curing** is the process in which the **concrete** is protected from loss of moisture and kept within a reasonable temperature range.
 - The result of this process is increased strength and decreased permeability.
 - **Curing** is also a key player in mitigating cracks in the **concrete**, which severely impacts durability.
- Curing can be defined as a procedure for insuring the hydration of the Portland cement in newly-placed concrete.
- It generally implies control of moisture loss and sometimes of temperature.

Need for curing: -

- Causes Hydration reaction of cement with water.
- Loss of water by evaporation can be prevented.
- Maintain conductive Temperature.
- For completing of Hydration reaction.
- For capillary segmentation.

Methods of curing: -

- Immersion
- Ponding
- Spraying
- Covering with wet sand
- Wetted Hessian (gunny bags)
- Membrane curing
- Water proof plastic sheeting

Immersion: -

- The precast concrete items are normally immersed in curing tanks.
- The cement and concrete test tubes, cylinders, beams etc. In the test laboratories are cured by immersion.

(Prepared By: Mr. Saurabh, Assistant Professor, civil)



fig-15

Ponding: -

- Pavement slabs, roof slab etc. are covered under water by making small ponds.



Fig:16 Ponding of slab

Spraying: -

- Vertical retaining wall or plastered surfaces or concrete columns etc. are cured by spraying water.



fig-17

Wet covering: -

- Wet gunny bags, hessian cloth, jute matting, straw etc., are wrapped to vertical surface for keeping the concrete wet.

(Prepared By: Mr. Saurabh, Assistant Professor, civil)

Covering with Gunny bags



Curing with water proof paper or sheet



Fig-18

Membrane curing: -

- In it, concrete is covered with membrane which effectively seal off the evaporation of water from concrete.
- It is carried out at the interface of the ground and concrete to prevent the absorption of water by the ground from the concrete.
- Membrane curing maintains a satisfactory state of wetness in the body of concrete to promote continuous hydration when original water/cement ratio used is not less than 0.5.



Fig-19

(Prepared By: Mr. Saurabh, Assistant Professor, civil)

CH-9

Importance and methods of non-destructive tests

Importance and methods of non-destructive tests

A number of non-destructive evaluation (NDE) tests for concrete members are available to determine in-situ strength and quality of concrete. Some of these tests are very useful in assessment of damage to RCC structures subjected to corrosion, chemical attack, and fire and due to other reasons. The term 'non destructive' is used to indicate that it does not impair the intended performance of the structural member being tested/investigated. The non-destructive evaluation have been broadly classified under two broad categories viz 'in-situ field test' and 'laboratory test'. These tests have been put under five categories depending on the purpose of test as under :

1. In-situ Concrete Strength
2. Chemical Attack
3. Corrosion Activity
4. Fire Damage
5. Structural Integrity/Soundness

Sl No	Test Method	Details
A. Insitu Concrete Strength:		
1	Rebound Hammer Test	A qualitative field test method to measure surface hardness of concrete
2	Ultrasonic Pulse Velocity	A qualitative field test by measurement of Ultrasonic Pulse Velocity (UPV)
3	Windsor Probe	A qualitative field test for assessment of near surface strength of concrete
4	Capo/Pull out test	-do-
5	a. Core cutting/ sampling b. Lab Testing of Cores	Field cum lab test method for assessing quality of concrete as under: - strength - density - texture - permeability
6	Load Test	A field test for assessing the load carrying capacity within the limits of elastic deformations

Table-1 NDT

1.REBOUND HAMMER (ASTM C 805-79)

(Prepared By: Mr. Saurabh, Assistant Professor, civil)

- The rebound hammer test is one of the non-destructive tests used to check the compressive strength of concrete.
- An empirical relationship has been determined between the amount absorbed by the concrete when given a high impact and its compressive strength. • the rebound hammer is designed to carry-out instant non-destructive test on concrete structure without damage and gives an immediate indication of the compressive strength of the concrete using the calibration curve applied each instrument.
- the hammer is simply pressed firmly against the concrete whereupon a powerful internal spring is first compressed and then tripped to deliver a hammer blow through the hardened concrete trip to the surface being tested.
- Rebound hammer test is done to find out the compressive strength of concrete by using rebound hammer as per IS: 13311 (Part 2) – 1992.
- Principle of the rebound hammer test is: The rebound of an elastic mass depends on the hardness of the surface against which its mass strikes.
- When the plunger of the rebound hammer is pressed against the surface of the concrete, the Spring-controlled mass rebounds and the extent of such a rebound depends upon the surface hardness of the concrete.
- The surface hardness and therefore the rebound is taken to be related to the compressive strength of the concrete.

(Prepared By: Mr. Saurabh, Assistant Professor, civil)

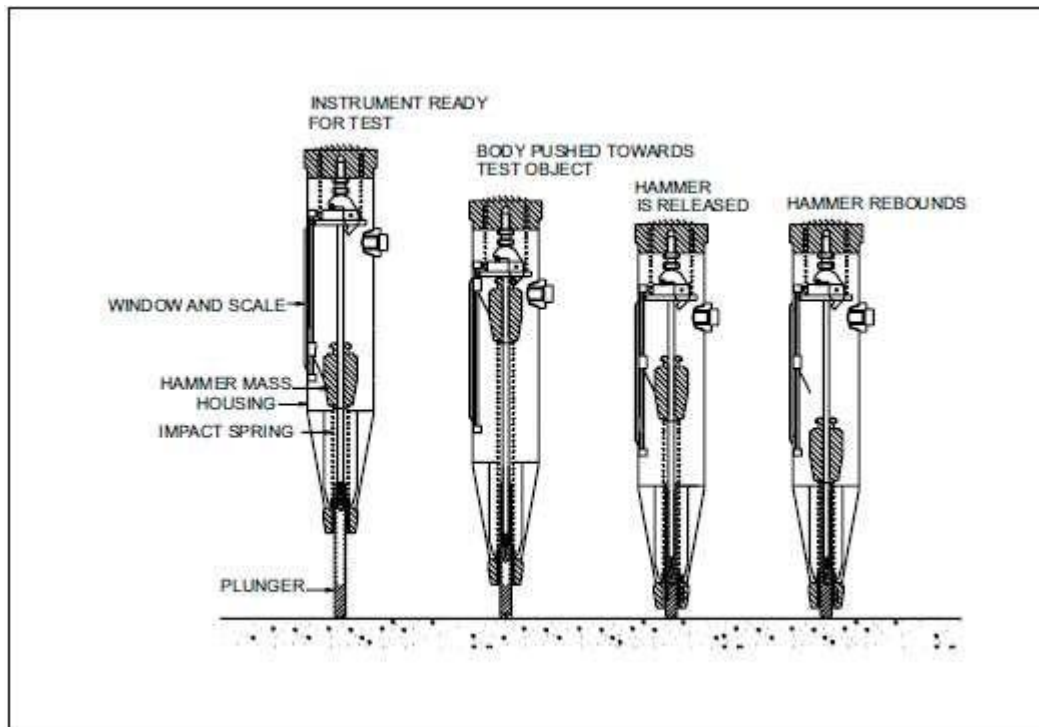

FIG-1 REBOUND HAMMER TEST

Interpretation of Results:

The rebound reading on the indicator scale has been calibrated by the manufacturer of the rebound hammer for horizontal impact.

Average Rebound Number	Quality of Concrete
>40	Very good hard layer
30 to 40	Good layer
20 to 30	Fair
< 20	Poor concrete
0	Delaminated

TABLE -2

ADVANTAGE

- Simple to use. No special experience is needed to conduct the test.
- Establishes uniformity of properties.
- Equipment is inexpensive and is readily available.
- A wide variety of concrete test hammers is available with an operational range of M10 to M70.

(Prepared By: Mr. Saurabh, Assistant Professor, civil)

- For rehabilitation of old Monuments.

DISADVANTAGE

- Evaluates only the local point and layer of masonry to which it is applied.
- No direct relationship to strength or deformation properties.
- Unreliable for the detection of flaws.
- Cleaning maintenance of probe and spring mechanism

Conclusion

- The rebound value can be measured discretionary, whereas the number of crushed specimens is limited.
- The combination of both methods is the best and most reliable procedure to determine the compressive strength of concrete structures.
- The method does not damage the structure like the classical method, where cores must be taken for the evaluation of the compressive strength. • It is a fast, inexpensive and easy to perform method using a light and portable test equipment.

Ultrasonic Pulse Velocity (IS 13311(Part 1) : 1992)

The ultrasonic pulse velocity method could be used to establish:

1. The homogeneity of the concrete,
2. The presence of cracks, voids and other imperfections,
3. Changes in the structure of the concrete which may occur with time,
4. The quality of the concrete in relation to standard requirements,
5. The quality of one element of concrete in relation to another, and
6. The values of dynamic elastic modulus of the concrete.

Principle of Test:

- The ultrasonic pulse is generated by an electro acoustical transducer., When the pulse is induced into the concrete from a transducer, it undergoes multiple reflections at the boundaries of the different material phases within the concrete.
- A complex system of stress waves is developed which includes longitudinal (compressional), shear (transverse) and surface (Rayleigh) waves. The receiving transducer detects the onset of the longitudinal waves, which is the fastest.
- Because the velocity of the pulses is almost independent of the geometry of the material through which they pass and depends only on its elastic properties, pulse velocity method is a convenient technique for investigating structural concrete.

(Prepared By: Mr. Saurabh, Assistant Professor, civil)

- The underlying principle of assessing the quality of concrete is that comparatively higher velocities are obtained when the quality of concrete in terms of density, homogeneity and uniformity is good.
- In case of poorer quality, lower velocities are obtained. If there is a crack, void or flaw inside the concrete which comes in the way of transmission of the pulses, the pulse strength is attenuated and it passes around the discontinuity, thereby making the path length longer. Consequently, lower velocities are obtained.
- The actual pulse velocity obtained depends primarily upon the materials and mix proportions of concrete. Density and modulus of elasticity of aggregate also significantly affect the pulse velocity.

The apparatus for ultrasonic pulse velocity measurement shall consist of the following:

- a) Electrical pulse generator
- b) Transducer - one pair
- c) Amplifier, and
- d) Electronic timing device.



Fig-2

(Prepared By: Mr. Saurabh, Assistant Professor, civil)

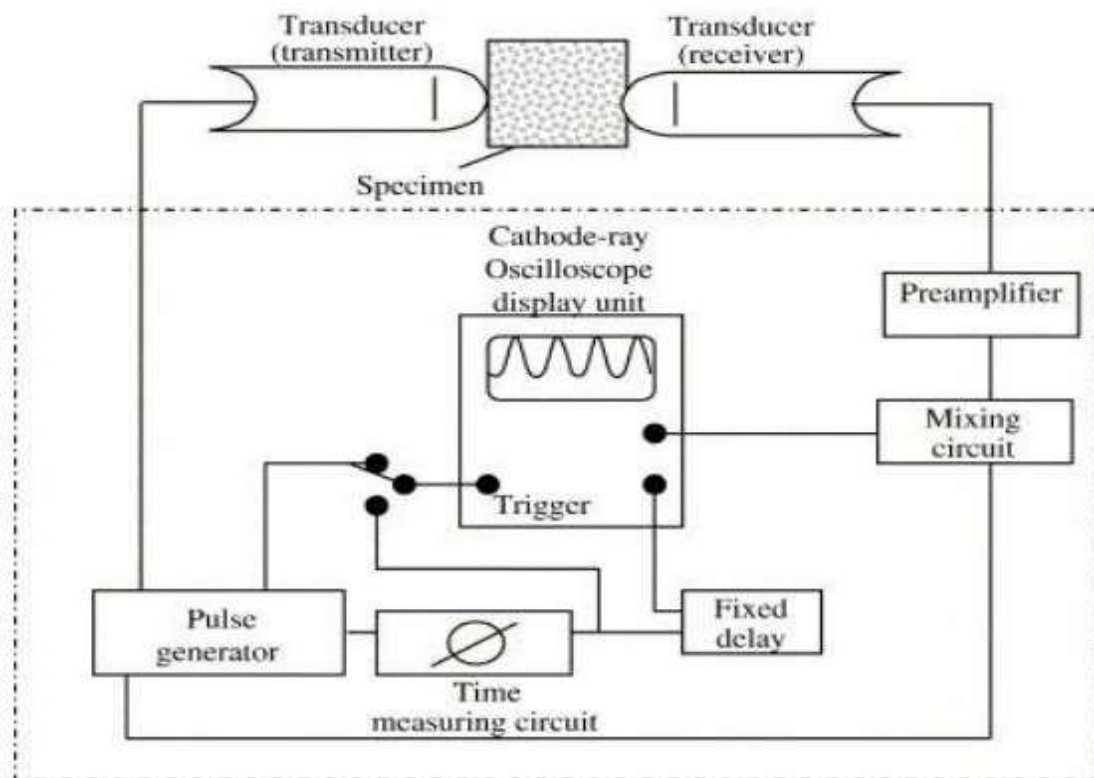

Influence of Test Conditions

- Influence of Surface Conditions and Moisture Content of Concrete
- Influence of Path Length, Shape and Size of the Concrete Member
- Influence of Temperature of Concrete
- Influence of Stress
- Effect of Reinforcing Bars

REFERENCE

CONCRETE TECHNOLOGY – A text book- ML Gambhir.